

Current Transducer LA 55-TP/SP1

For the electronic measurement of currents: DC, AC, pulsed..., with galvanic separation between the primary circuit and the secondary circuit.

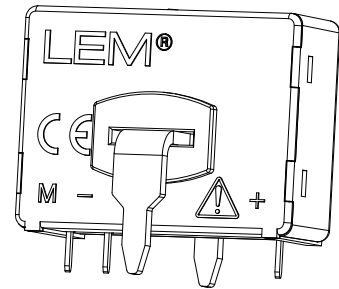

$$I_{PN} = 50 \text{ A}$$



Electrical data

I_{PN}	Primary nominal rms current	50	A			
I_{PM}	Primary current, measuring range	0 .. ± 100	A			
R_M	Measuring resistance @	$T_A = 70 \text{ }^\circ\text{C}$	$T_A = 85 \text{ }^\circ\text{C}$			
		$R_{M \min}$ $R_{M \max}$	$R_{M \min}$ $R_{M \max}$			
		with $\pm 12 \text{ V}$	@ $\pm 50 \text{ A}_{\max}$	0 215	0 210	Ω
		@ $\pm 100 \text{ A}_{\max}$	0 35	0 30	Ω	
with $\pm 15 \text{ V}$	@ $\pm 50 \text{ A}_{\max}$	0 335	70 330	Ω		
@ $\pm 100 \text{ A}_{\max}$	0 95	70 90	Ω			
I_{SN}	Secondary nominal rms current	25	mA			
K_N	Conversion ratio	1 : 2000				
U_C	Supply voltage ($\pm 5 \%$)	$\pm 12 \dots 15$	V			
I_C	Current consumption	10 (@ $\pm 15 \text{ V}$) + I_S	mA			

Accuracy - Dynamic performance data

X	Accuracy @ I_{PN} , $T_A = 25 \text{ }^\circ\text{C}$	@ $\pm 15 \text{ V} (\pm 5 \%)$	± 0.65	%
		@ $\pm 12 \dots 15 \text{ V} (\pm 5 \%)$	± 0.90	%
ϵ_L	Linearity error		< 0.15	%
I_O	Offset current @ $I_P = 0$, $T_A = 25 \text{ }^\circ\text{C}$	Typ		
		Max	± 0.10	mA
I_{OM}	Magnetic offset current ¹⁾ @ $I_P = 0$ and specified R_M , after an overload of $3 \times I_{PN}$		± 0.15	mA
I_{OT}	Temperature variation of I_O	- 25 $^\circ\text{C}$.. + 85 $^\circ\text{C}$	± 0.05 ± 0.30	mA
		- 40 $^\circ\text{C}$.. - 25 $^\circ\text{C}$	± 0.10 ± 0.50	mA
t_{ra}	Reaction time		< 500	ns
t_r	Step response time ²⁾ to 90 % of I_{PN}		< 1	μs
di/dt	di/dt accurately followed		> 200	A/ μs
BW	Frequency bandwidth (- 1 dB)		DC .. 200	kHz

General data

T_A	Ambient operating temperature	- 40 .. + 85	$^\circ\text{C}$
T_S	Ambient storage temperature	- 40 .. + 90	$^\circ\text{C}$
R_S	Resistance of secondary winding	@ $T_A = 70 \text{ }^\circ\text{C}$	145 Ω
		@ $T_A = 85 \text{ }^\circ\text{C}$	150 Ω
m	Mass	25	g
	Standards	EN 50178: 1997 UL 508: 2010	

Notes: ¹⁾ Result of the coercive field of the magnetic circuit
²⁾ With a di/dt of 100 A/ μs .

Features

- Closed loop (compensated) current transducer using the Hall effect
- Insulating plastic case recognized according to UL 94-V0.

Special features

- $I_{PM} = 0 \dots \pm 100 \text{ A}$
- $K_N = 1 : 2000$.

Advantages

- Excellent accuracy
- Very good linearity
- Low temperature drift
- Optimized response time
- Wide frequency bandwidth
- No insertion losses
- High immunity to external interference
- Current overload capability.

Applications

- AC variable speed drives and servo motor drives
- Static converters for DC motor drives
- Battery supplied applications
- Uninterruptible Power Supplies (UPS)
- Switched Mode Power Supplies (SMPS)
- Power supplies for welding applications.

Application domain

- Industrial.

Current Transducer LA 55-TP/SP1

Insulation coordination

U_d	Rms voltage for AC insulation test, 50 Hz, 1 min	2.5	kV
\hat{U}_w	Impulse withstand voltage 1.2/50 μ s	7.5	kV
		Min	
d_{cp}	Creepage distance ¹⁾	8.3	mm
d_{cl}	Clearance ²⁾	8.3	mm
CTI	Comparative tracking index (group I)	600	

Notes: ¹⁾ Distance between hole busbar and winding

²⁾ Direct distance between hole busbar and winding.

Applications examples

According to EN 50178 and IEC 61010-1 standards and following conditions:

- Over voltage category OV 3
- Pollution degree PD2
- Non-uniform field

	EN 50178	IEC 61010-1
$d_{cp}, d_{cl}, \hat{U}_w$	Rated insulation voltage	Nominal voltage
Basic insulation	1000 V	1000 V
Reinforced insulation	600 V	300 V

Safety

This transducer must be used in limited-energy secondary circuits according to IEC 61010-1.



This transducer must be used in electric/electronic equipment with respect to applicable standards and safety requirements in accordance with the manufacturer's operating instructions.



Caution, risk of electrical shock

When operating the transducer, certain parts of the module can carry hazardous voltage (eg. primary busbar, power supply).

Ignoring this warning can lead to injury and/or cause serious damage.

This transducer is a build-in device, whose conducting parts must be inaccessible after installation.

A protective housing or additional shield could be used.

Main supply must be able to be disconnected.

Dimensions LA 55-TP/SP1 (in mm)

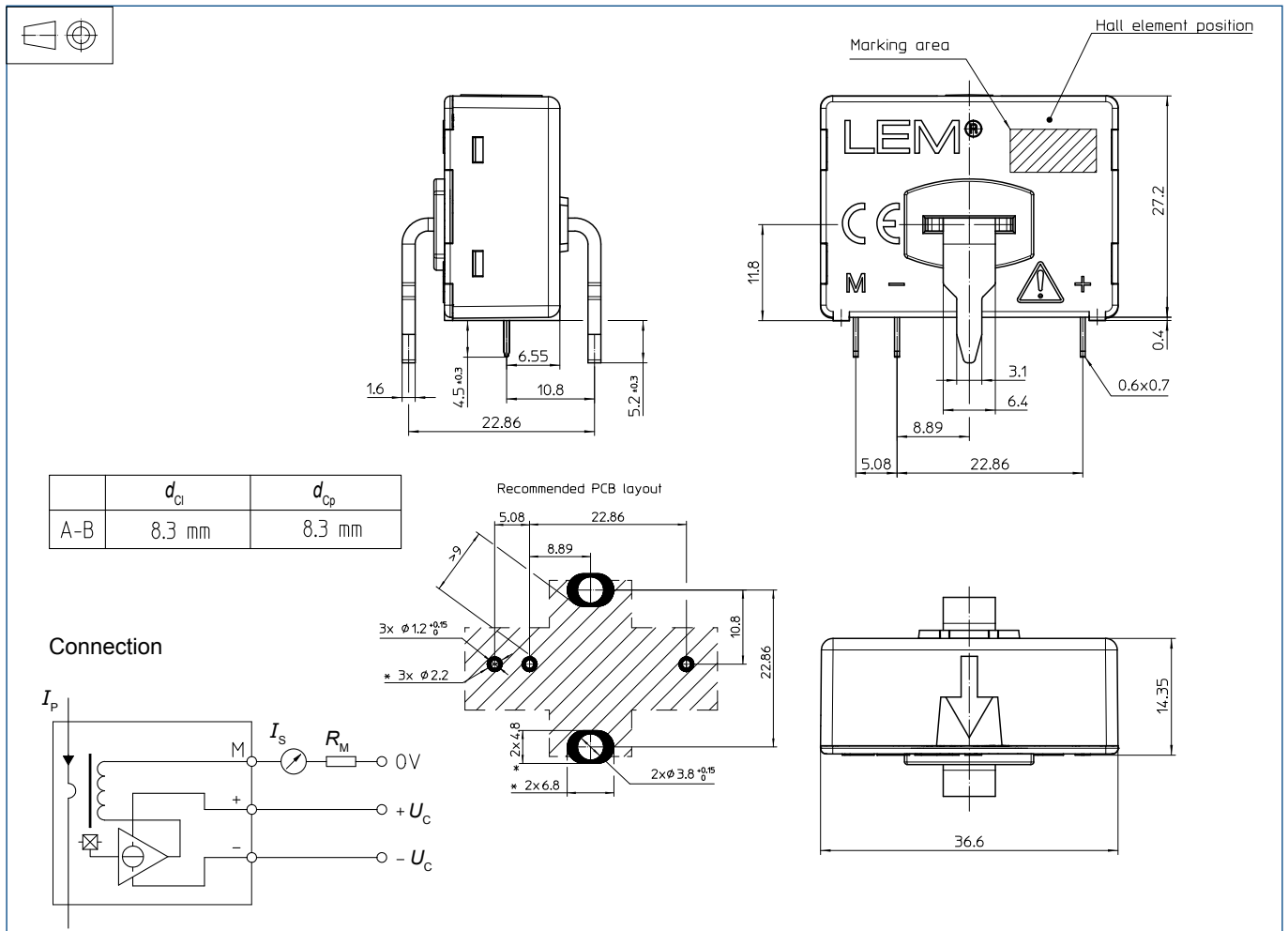

Mechanical characteristics

- General tolerance ± 0.2 mm
- Fastening & connection of primary bus bar 6.4×1.6 mm
- Recommended PCB hole 3.8 mm
- Fastening & connection of secondary 3 pins 0.6×0.7 mm
- Recommended PCB hole $\phi 1.2$ mm

Remarks

- I_s is positive when I_p flows in the direction of the arrow.
- Temperature of the primary conductor should not exceed 90°C .
- Installation of the transducer must be done unless otherwise specified on the datasheet, according to LEM Transducer Generic Mounting Rules. Please refer to LEM document N°ANE120504 available on our Web site: [Products/Product Documentation](#).