

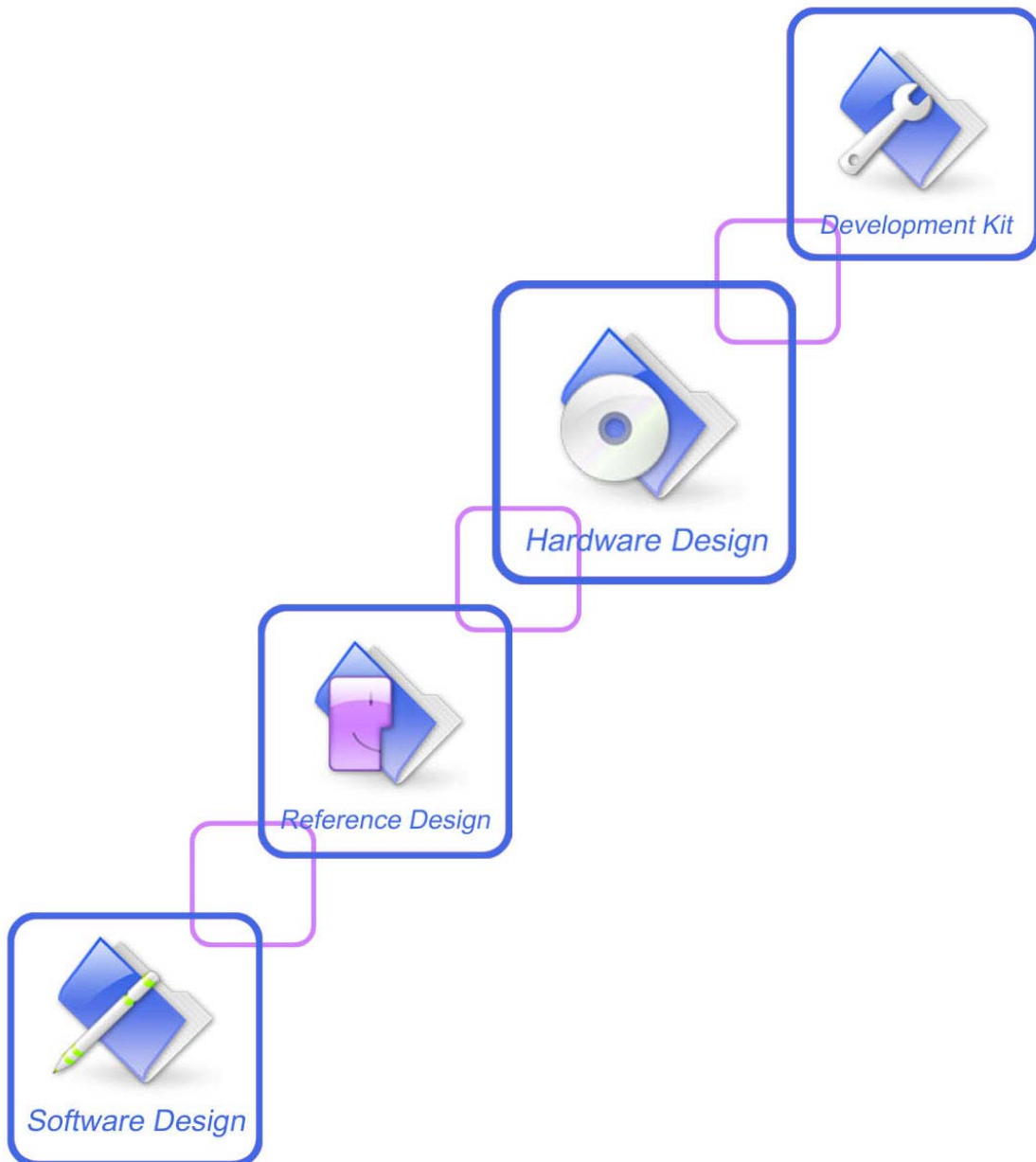

SIM5360_Hardware Design_V1.03



Document Title	SIM5360 Hardware Design
Version	1.03
Date	2014-07-03
Status	Release
Document Control ID	SIM5360_Hardware Design_V1.03

General Notes

SIMCom offers this information as a service to its customers, to support application and engineering efforts that use the products designed by SIMCom. The information provided is based upon requirements specifically provided to SIMCom by the customers. SIMCom has not undertaken any independent search for additional relevant information, including any information that may be in the customer's possession. Furthermore, system validation of this product designed by SIMCom within a larger electronic system remains the responsibility of the customer or the customer's system integrator. All specifications supplied herein are subject to change.

Copyright

This document contains proprietary technical information which is the property of SIMCom Limited, copying of this document and giving it to others and the using or communication of the contents thereof, are forbidden without express authority. Offenders are liable to the payment of damages. All rights reserved in the event of grant of a patent or the registration of a utility model or design. All specification supplied herein are subject to change without notice at any time.

Copyright © Shanghai SIMCom Wireless Solutions Ltd. 2014

Contents

Revision History	9
1 Introduction	10
1.1 Product Outline	10
1.2 Hardware Interface Overview	11
1.3 Hardware Diagram	11
1.4 Functional Overview	12
2 Package Information	13
2.1 Pin Configuration	13
2.2 Pin description	15
2.3 Package Dimensions	18
2.4 Footprint Recommendation	20
3 Application Interface Specification	20
3.1 Power Supply	20
3.1.1 Power Supply Pin	21
3.1.2 Design Guide	21
3.1.3 RTC Backup	23
3.2 Power on/off Time Sequence	25
3.2.1 Power on Sequence	25
3.2.2 Power off Sequence	26
3.3 UART Interface	27
3.3.1 Pin Description	29
3.3.2 Application Guide	29
3.4 SD/MMC Interface	31
3.4.1 Pin Description	31
3.4.2 Design guide	32
3.5 USIM Interface	32
3.5.1 Pin description	32
3.5.2 Application Guide	33
3.5.3 Recommend Components	34
3.6 I2C Interface	35
3.6.1 Pin Description	36
3.6.2 Signal Description	36
3.6.3 Design Guide	36
3.7 Keypad Interface	36
3.7.1 Pin Description	36
3.7.2 Application Guide	37
3.8 USB Interface	38
3.8.1 Application Guide	38
3.9 SPI Interface	39
3.9.1 Pin Description	39
3.10 GPIO Interface	39

3.10.1	Pin Description	40
3.10.2	Application Guide	41
3.11	PCM Interface	42
3.11.1	Pin Description	43
3.11.2	Signal Description	43
3.11.3	Application Guide	46
3.12	GNSS (GPS and GLONASS).....	47
3.12.1	Technical specification	47
3.12.2	Operate Mode	48
3.12.3	Application Guide	48
3.13	Multi-functional interface.....	50
3.13.1	Sink Current Source	50
3.13.2	Reset Function	51
3.13.3	ADC.....	51
3.13.4	LDO.....	52
4	RF Specification	53
4.1	RF Specification	53
4.2	Operating Specification	54
4.3	Antenna Design Guide.....	55
5	Reliability and Operating Characteristics.....	56
5.1	Electronic Characteristics	56
5.2	Operating Mode	57
5.2.1	Operating Modes Overview	57
5.2.2	Minimize Power Consumption	58
5.3	Current Consumption.....	59
5.4	EMC and ESD Notes	61
6	Guide for Production.....	62
6.1	Top and Bottom View of SIM5360	62
6.2	Typical Solder Reflow Profile	62
6.3	Moisture Sensitivity Level (MSL).....	63
6.4	Stencil Foil Design Recommendation	63
Appendix	64
A.	Reference Design	64
B.	SIM5360 GPIOs List.....	65
C.	Digital I/O Characteristics	65
D.	Related Documents	66
E.	Terms and Abbreviations.....	68
F.	Safety Caution.....	70

Table Index

Table 1: SIM5360 series frequency bands.....	10
Table 2: General Feature	12
Table 3: Pin definition.....	14
Table 4: Pin description.....	15
Table 5: Pin description.....	21
Table 6: Recommended zener diode models	22
Table 7: Power on timing	26
Table 8: Power off timing	27
Table 9: Pin description.....	29
Table 10: Logic level.....	29
Table 11: Pin description.....	31
Table 12: Electronic characteristic	32
Table 16: Pin description.....	32
Table 17: Electronic characteristic	33
Table 18: Pin description.....	36
Table 19: Pin description.....	36
Table 20: GPIO configuration	37
Table 21: Electronic characteristic	38
Table 22: Pin description.....	39
Table 23: Electronic characteristic	39
Table 24: Pin description.....	40
Table 25: Electronic characteristic	40
Table 26: LED status.....	41
Table 27: Control status	42
Table 28: Pin description.....	43
Table 29: Electronic characteristic	43
Table 30: Timing parameters.....	44
Table 31: Timing parameters.....	46
Table 32: Electronic characteristic	50
Table 33: Electronic Characteristics.....	51
Table 34: Electronic characteristic	52
Table 35: Conducted transmission power	53
Table 36: Operating frequencies	53
Table 37: Conducted receive sensitivity.....	53
Table 38: GPRS/EDGE data throughout	54
Table 39: HSDPA throughout.....	54
Table 40: Absolute maximum ratings.....	56
Table 41: Recommended operating ratings	56
Table 42: Operating temperature.....	56
Table 43: Operating Modes Overview	57
Table 44: Current consumption.....	59
Table 45: The ESD performance measurement table (Temperature: 25°C, Humidity: 45%)	61

Table 46: SIM5360 GPIOs list.....	65
Table 47: Digital I/O characteristics.....	65
Table 48: Related documents.....	66
Table 49: Terms and Abbreviations.....	68
Table 50: Safety caution.....	70

SIMCOM CONFIDENTIAL FILE

Figure Index

Figure 1: SIM5360 functional architecture	11
Figure 2: Pin view	13
Figure 3: Top dimensions (Unit: mm)	18
Figure 4: Side dimensions (Unit: mm)	19
Figure 5: Bottom dimensions (Unit: mm)	19
Figure 6: Footprint recommendation (Unit: mm)	20
Figure 7: VBAT voltage drop during burst emission (GSM/GPRS)	21
Figure 8: VBAT input application circuit	22
Figure 9: Reference circuit of the LDO power supply	22
Figure 10: Reference circuit of the DCDC power supply	23
Figure 11: RTC supply from capacitor	24
Figure 12: RTC supply from non-chargeable battery	24
Figure 13: RTC supply from rechargeable battery	24
Figure 15: Power on Timing Sequence	25
Figure 16: Power off timing sequence	27
Figure 17: UART1 Full modem	28
Figure 18: Null modem (UART1 and UART2)	28
Figure 19: RI behaviour in NULL Modem	30
Figure 20: RI behaviour in FULL Modem	30
Figure 21: Reference circuit of level shift	31
Figure 22: SD interface circuit	32
Figure 23: USIM interface reference circuit	34
Figure 24: Amphenol SIM card socket	35
Figure 25: Reference circuit	37
Figure 26: USB interface	38
Figure 27: Application circuit	41
Figure 28: Flight mode switch	42
Figure 29: Synchrony timing	43
Figure 30: EXT CODEC to MODULE timing	44
Figure 31: MODULE to EXT CODEC timing	44
Figure 32: Synchrony timing	45
Figure 33: EXT CODEC to MODULE timing	45
Figure 34: MODULE to EXT CODEC timing	46
Figure 35: Reference Circuit of PCM Application with Audio Codec	47
Figure 36: Active antenna circuit	49
Figure 37: Passive antenna circuit (Default)	49
Figure 38: Current drive	50
Figure 39: Reset circuit	51
Figure 40: Antenna matching circuit (MAIN_ANT)	55
Figure 41: Antenna matching circuit (DIV_ANT)	56
Figure 42: Top and bottom view of SIM5360	62
Figure 43: The ramp-soak-spike reflow profile of SIM5360	62

Figure 45: Reference design 64

SIMCOM CONFIDENTIAL FILE

Revision History

Data	Version	Description of change	Author
2014-02-28	1.01	Original	Libing
2014-04-18	1.02	Add UART2 description	Libing
2014-07-03	1.03	Modify pin names of SIM5360	Libing

SIMCOM CONFIDENTIAL FILE

1 Introduction

This document describes electronic specifications, RF specifications, function interface, mechanical characteristic and testing conclusions of the SIMCom SIM5360 module. With the help of this document and other SIM5360 software application notes, user guides, users can quickly understand and use SIM5360 module to design and develop applications quickly.

1.1 Product Outline

Designed for global market, SIM5360 is a quad-band GSM/GPRS/EDGE and dual-band UMTS /HSPA+ that works on frequencies of GSM 850MHz, EGSM 900 MHz, DCS 1800 MHz, PCS 1900MHz and WCDMA 2100/900MHz, 1900/850 MHz, 2100/850 MHz. User can choose the module based on the wireless network configuration. In this document, the entire radio band configuration of SIM5360 series is described in the following table.

Table 1: SIM5360 series frequency bands

Standard	Frequency	SIM5360J	SIM5360E	SIM5360A
GSM	GSM 850MHz	✓	✓	✓
	EGSM 900MHz	✓	✓	✓
	DCS1800MHz	✓	✓	✓
	PCS1900MHz	✓	✓	✓
WCDMA	WCDMA 850MHz	✓		✓
	WCDMA 900MHz		✓	
	WCDMA 1900MHz			✓
	WCDMA 2100MHz	✓	✓	
HSPA	HSDPA	✓	✓	✓
	HSUPA	✓	✓	✓
GNSS	GPS	✓	✓	✓
	GLONASS	✓	✓	✓

With a tiny configuration of 30*30*2.9 mm and integrated functions, SIM5360 can meet almost any space requirement in users' application, such as Smart phone, PDA phone, industrial handhelds, machine-to-machine, vehicle applications, etc..

There are 82 pins on SIM5360, which provide most application interfaces for customers' board.

1.2 Hardware Interface Overview

Sub-interfaces are described in detail in the next chapter, which includes:

- Power Supply
- USB Interface
- UART Interface
- SD card Interfaces
- SIM Interface
- GPIO
- ADC
- LDO Power Output
- Current Sink Source
- PCM Interface
- Keypad Interface
- SPI Interface
- RTC
- I2C Interface

1.3 Hardware Diagram

The global architecture of the SIM5360 Embedded module is described in the figure below.

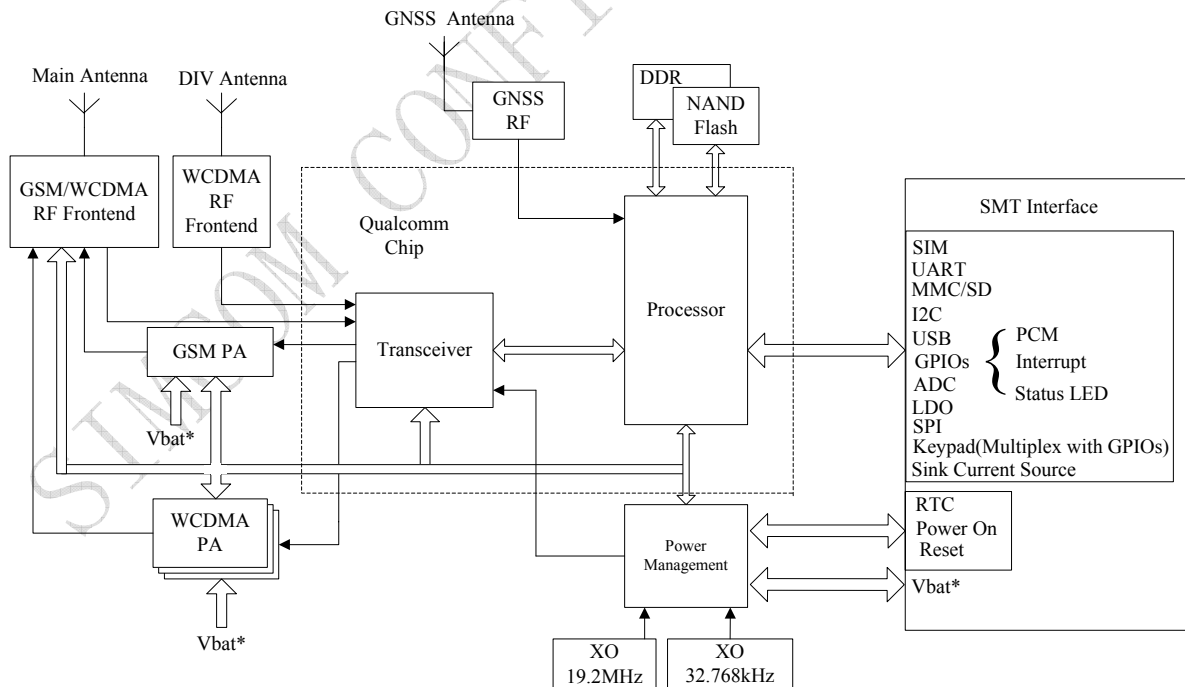

Figure 1: SIM5360 functional architecture

1.4 Functional Overview

Table 2: General Feature

Feature	Implementation
Power supply	Single supply voltage 3.4~4.2V
Transmission data	<ul style="list-style-type: none"> ● Dual-mode UMTS/HSPA+/EDGE/GPRS operation ● GPRS Class B, multislot class 12 operation, Supports coding scheme: CS1-4 ● EDGE multislot class 12 operation, Supports coding schemes MSC1-9 ● UMTS R99 data rates-384 kbps DL/UL ● Category 6 HSDPA -14.4 Mbps HSUPA-5.76 Mbps ● CSD feature: 9.6, 14.4, 64 kbps UL/DL
GNSS	<ul style="list-style-type: none"> ● GNSS engine (GPS and GLONASS) ● Protocol: NMEA ● Mobile-assisted mode ● Mobile-based mode ● Standalone mode
SMS	<ul style="list-style-type: none"> ● MT, MO, CB, Text and PDU mode ● SMS storage: SIM card or ME(default) ● Support transmission of SMS alternatively over CSD or GPRS. User can choose preferred mode.
SIM interface	Support identity card: 1.8V, 3V.
Audio features(optional)	Speech codec modes: <ul style="list-style-type: none"> ● Half Rate (ETS 06.20) ● Full Rate (ETS 06.10) ● Enhanced Full Rate (ETS 06.50 / 06.60 / 06.80) ● AMR (WCDMA) ● AMR+QCP (GSM) ● A5/1, A5/2, and A5/3 ciphering
UART interface	<ul style="list-style-type: none"> ● Support full mode or null mode ● Support AT command
USB	Support USB2.0 Slave mode
Rx-diversity	Support UMTS Rx-diversity.
Phonebook management	Support phonebook types: SM, FD, LD, RC, ON, MC.
SIM application toolkit	Support SAT class 3, GSM 11.14 Release 98 Support USAT
Real Time Clock	Support RTC
Physical characteristics	Size:30*30*2.9mm Weight:5.7 g
Firmware upgrade	Firmware upgrade over USB interface
PCM	Multiplex on GPIOs. Used for analog audio function with external codec. Support long frame sync and short frame sync.

	Support 8-bit A-law, μ -law and 16-bit linear data formats. Support master and slave mode, but must be the master in long frame sync.
Temperature range	<ul style="list-style-type: none"> ● Normal operation temperature: -30°C to +80°C ● Extended operation temperature: -40°C to +85°C ● Storage temperature -45°C to +90°C

2 Package Information

2.1 Pin Configuration

All hardware interfaces which connect SIM5360 to customers' application platform are through 82 pins pads (Metal half hole). Figure 2 is SIM5360 outline diagram.

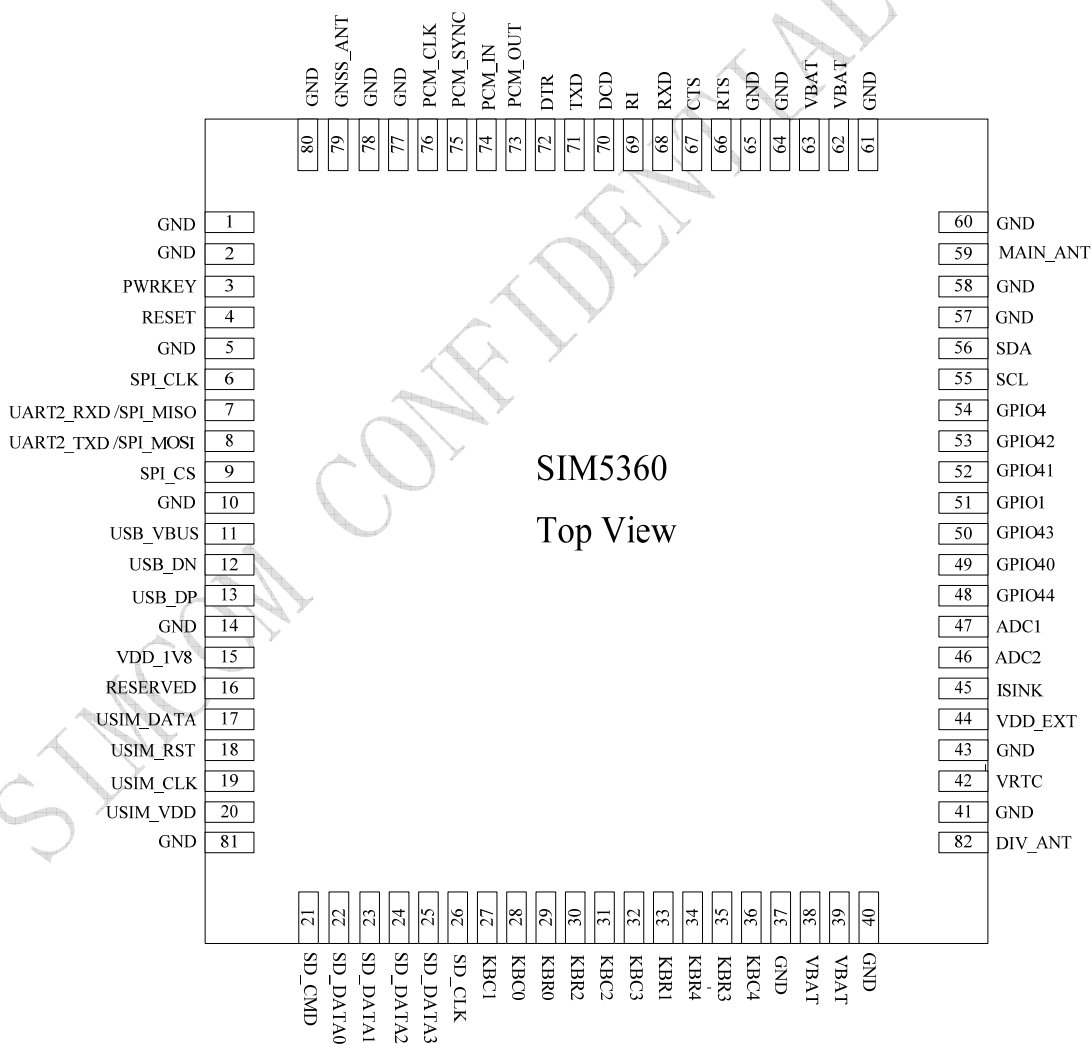

Figure 2: Pin view

Table 3: Pin definition

Pin No.	Define	Pin No.	Define
1	GND	2	GND
3	POWERKEY	4	RESET
5	GND	6	SPI_CLK
7	UART2_RXD / SPI_MISO	8	UART2_TXD / SPI_MOSI
9	SPI_CS	10	GND
11	USB_VBUS	12	USB_DN
13	USB_DP	14	GND
15	VDD_1V8	16	RESERVED
17	USIM_DATA	18	USIM_RST
19	USIM_CLK	20	USIM_VDD
21	SD_CMD	22	SD_DATA0
23	SD_DATA1	24	SD_DATA2
25	SD_DATA3	26	SD_CLK
27	KBC1	28	KBC0
29	KBR0	30	KBR2
31	KBC2	32	KBC3
33	KBR1	34	KBR4
35	KBR3	36	KBC4
37	GND	38	VBAT
39	VBAT	40	GND
41	GND	42	VRTC
43	GND	44	VDD_EXT
45	ISINK	46	ADC2
47	ADC1	48	GPIO44
49	GPIO40	50	GPIO43
51	NETLIGHT/GPIO1	52	GPIO41
53	GPIO42	54	GPIO4
55	SCL	56	SDA
57	GND	58	GND
59	MAIN_ANT	60	GND
61	GND	62	VBAT
63	VBAT	64	GND
65	GND	66	RTS

67	CTS	68	RXD
69	RI	70	DCD
71	TXD	72	DTR
73	PCM_OUT	74	PCM_IN
75	PCM_SYNC	76	PCM_CLK
77	GND	78	GND
79	GNSS_ANT	80	GND
81	GND	82	DIV_ANT

2.2 Pin description

IO Parameters Definition

Pin Type	Description
PI	Power input
PO	Power output
IO	Bidirectional input / output
DI	Digital input
DO	Digital output
AI	Analog input

Table 4: Pin description

Pin name	Pin No.	I/O	Description	Comment
Power Supply				
VBAT	38,39,62,63	PI	Power supply voltage	
VRTC	42	I/O	Power supply for RTC	If it is unused, keep open.
VDD_EXT	44	PO	LDO power output for SD card circuit or other external circuit. This LDO output voltage can be changed by the AT command "AT+CVAUXV".	
VDD_1V8	15	PO	The 1.8V SMPS output for external circuit, such as level shift circuit.	
GND	1,2,5,10,14,37,40,41,43,57,58,60,61,64,65,77,78,80,81		Ground	
Power on/off				

POWERKEY	3	DI	POWERKEY should be pulled low at least 180ms to power on or 500ms to power off the module.	
SD interface				
SD_CMD	21	I/O	SDIO command	If it is unused, keep open.
SD_DATA0	22	I/O	SDIO data	
SD_DATA1	23	I/O	SDIO data	
SD_DATA2	24	I/O	SDIO data	
SD_DATA3	25	I/O	SDIO data	
SD_CLK	26	DO	SDIO clock	
USIM interface				
USIM_DATA	17	I/O	SIM Data Output/Input	All signals of SIM interface should be protected against ESD/EMC.
USIM_RST	18	DO	SIM Reset	
USIM_CLK	19	DO	SIM Clock	
USIM_VDD	20	PO	Voltage Supply for SIM card Support 1.8V or 3V SIM card	
SPI/UART2 interface				
SPI_CLK	6	DO	SPI clock	If it is unused, keep open.
UART2_RXD /SPI_MISO	7	DI	Receive data of UART2 / SPI (master only) master in/slave out data	
UART2_TXD / SPI_MOSI	8	DO	Transmit data of UART2 / SPI (master only) master out/slave in data	
SPI_CS	9	DO	SPI chip-select	
USB				
USB_VBUS	11	PI	USB power supply input	They are compliant with the USB 2.0 specification. If it is unused, keep open.
USB_DN	12	I/O	Minus (-) line of the differential, bi-directional USB signal to/from the	
USB_DP	13	I/O	Plus (+) line of the differential, bi-directional USB signal to/from the	
UART1 interface				
RTS	66	DO	Request to send	RXD has been pulled down with a 12kR resistor to ground in the module. If it is unused, keep open.
CTS	67	DI	Clear to Send	
RXD	68	DI	Receive Data	
RI	69	DO	Ring Indicator	
DCD	70	DO	Carrier detects	
TXD	71	DO	Transmit Data	
DTR	72	DI	DTE get ready	
I2C interface				

SCL	55	DO	I2C clock output	None pulled up resistors in the module. Pulled up with a 2.2kR resistor to 1.8V externally. If it is unused, keep open.
SDA	56	I/O	I2C data	

Keypad interface

KBR0	29	DO	Bit 0 drive to the pad matrix	All Keypad pins can be configured as GPIOs. If it is unused, keep open.
KBR1	33	DO	Bit 1 drive to the pad matrix	
KBR2	30	DO	Bit 2 drive to the pad matrix	
KBR3	35	DO	Bit 3 drive to the pad matrix	
KBR4	34	DO	Bit 4 drive to the pad matrix	
KBC0	28	DI	Bit 0 for sensing key press on pad matrix	
KBC1	27	DI	Bit 1 for sensing key press on pad matrix	
KBC2	31	DI	Bit 2 for sensing key press on pad matrix	
KBC3	32	DI	Bit 3 for sensing key press on pad matrix	
KBC4	36	DI	Bit 4 for sensing key press on pad matrix	

PCM interface

PCM_OUT/GPIO5	73	DO	PCM data output. It also can be multiplexed as GPIO5.	If it is unused, keep open.
PCM_IN/GPIO0	74	DI	PCM data input. It also can be multiplexed as GPIO0 with module wake/interrupt.	
PCM_SYNC/GPIO 2	75	DO	PCM data frame sync signal. It also can be multiplexed as GPIO2.	
PCM_CLK/GPIO3	76	DO	PCM data bit clock. It also can be multiplexed as GPIO3.	

GPIOs

NETLIGHT/GPIO1	51	DO	Output PIN as LED control for network status.	If it is unused, keep open.
GPIO4	54	DI	Input PIN as RF operating control.	
GPIO40	49	DO	Output PIN as operating status indicating of module.	
GPIO41	52	DO	General input/output PIN. It can be used as wake/interrupt signal to host from module	
GPIO43	50	DI	General input/output PIN. It can be used as wake/interrupt signal to module from host.	
GPIO44	48	I/O	General input/output PIN.	

GPIO42	53	I/O	General input/output PIN.	
RF interface				
MAIN_ANT	59		MAIN ANT soldering pad	
GNSS_ANT	79	AI	GNSS ANT soldering pad	
DIV_ANT	82	AI	Diversity ANT soldering pad	
Other interface				
RESET	4	DI	System reset in, active low.	
ISINK	45	DI	Current source of ground-referenced current sink	Refer to 3.13.1
ADC1	47	AI	Analog Digital Converter Input	Refer to 3.13.3
ADC2	46	AI	Analog Digital Converter Input	
RESERVED	16		Reserved	

2.3 Package Dimensions

The following figure shows mechanical dimensions of SIM5360.

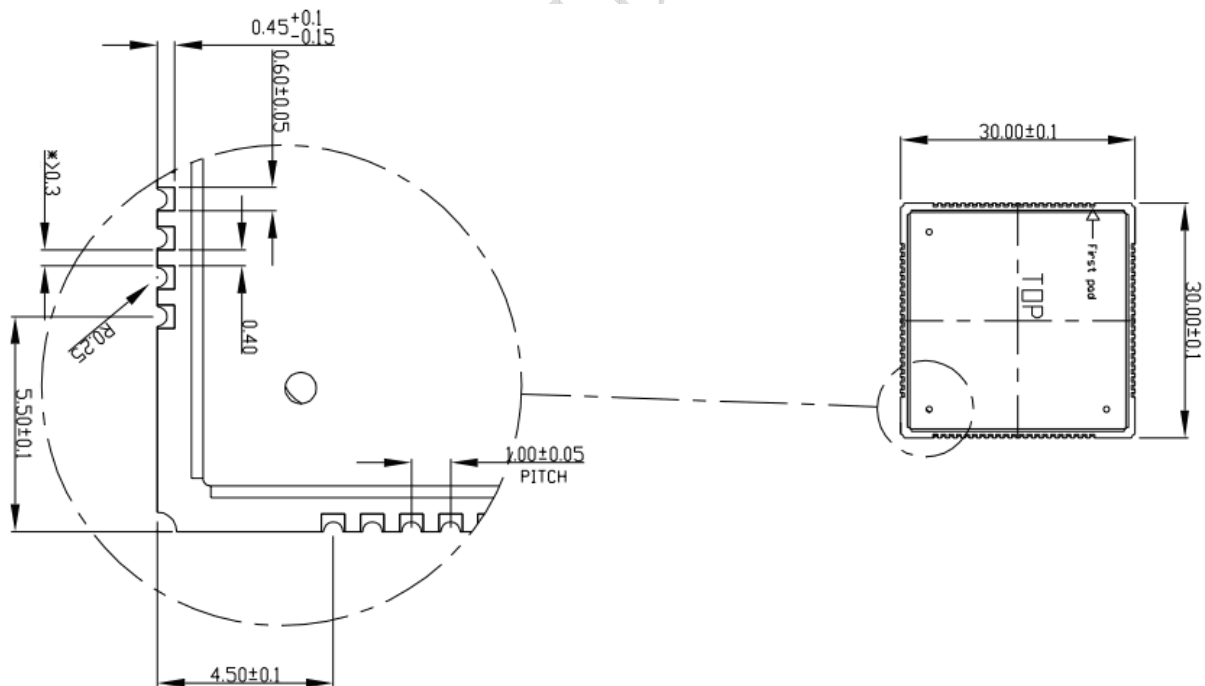

Figure 3: Top dimensions (Unit: mm)

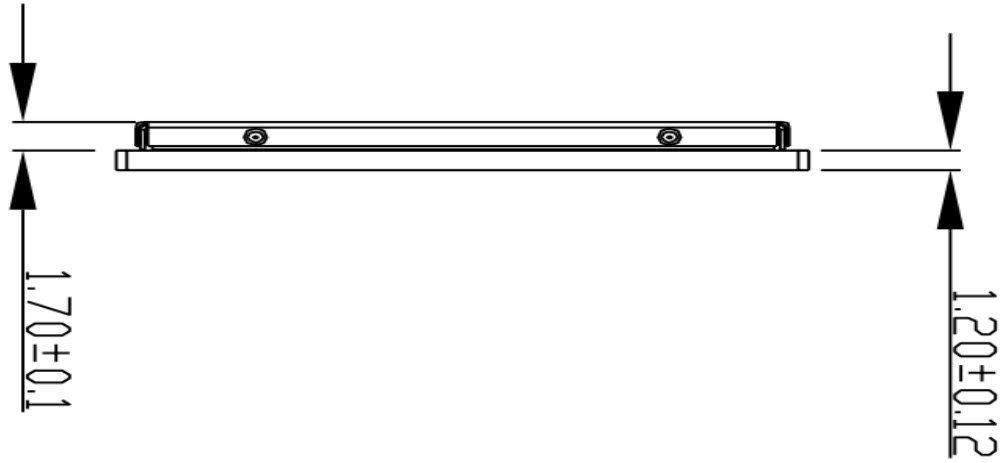

Figure 4: Side dimensions (Unit: mm)

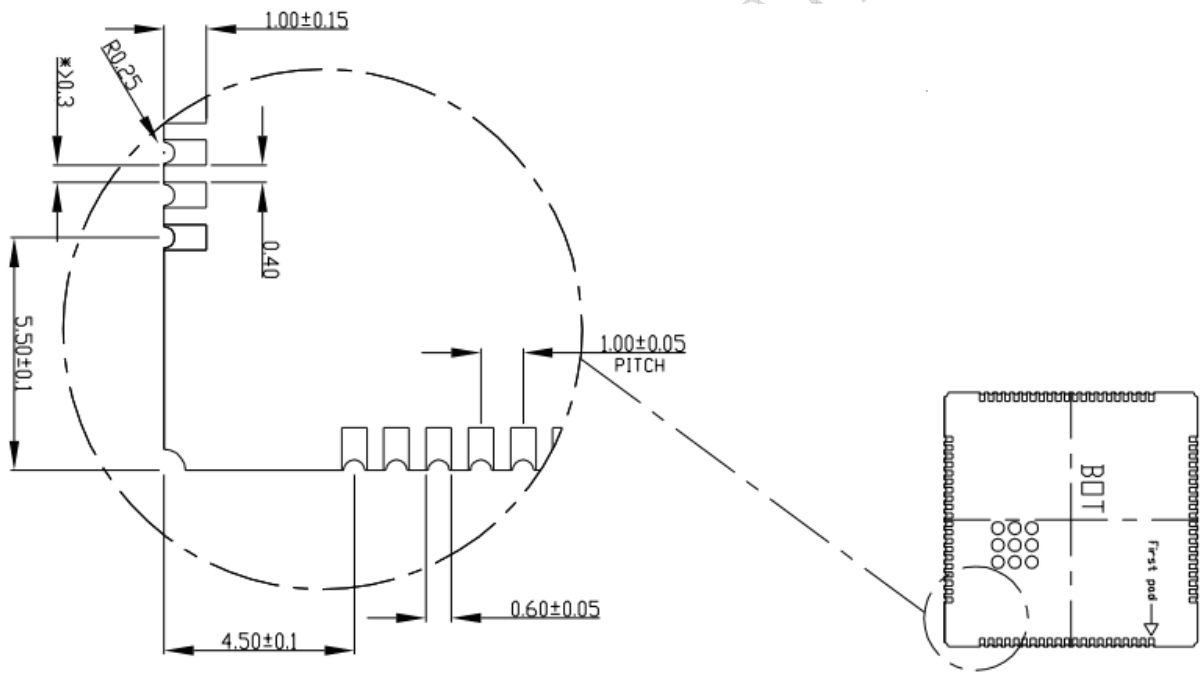

Figure 5: Bottom dimensions (Unit: mm)

2.4 Footprint Recommendation

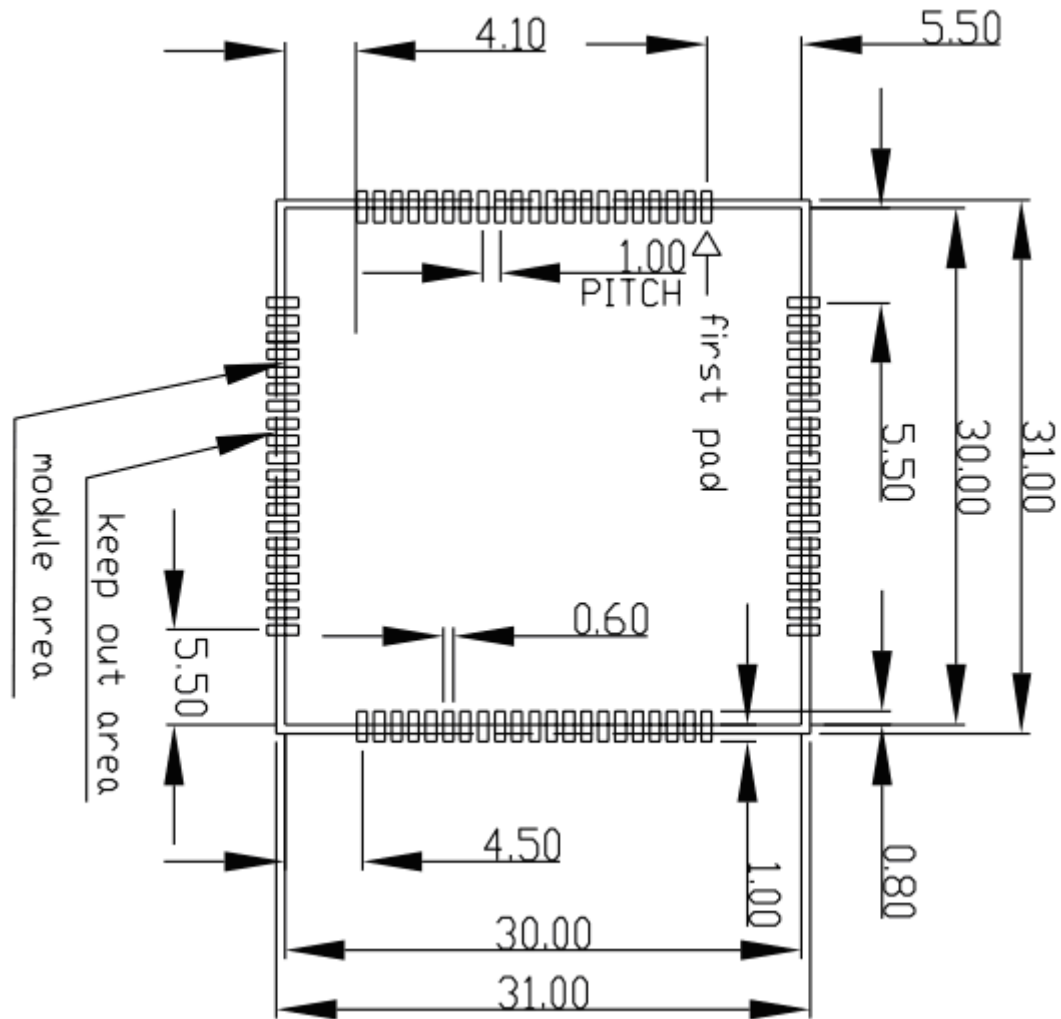

Figure 6: Footprint recommendation (Unit: mm)

3 Application Interface Specification

3.1 Power Supply

The power supply pins of SIM5360 include four VBAT pins (pin 62&63, pin 38&39). VBAT directly supplies the power to RF circuit and baseband circuit. All four VBAT pins of SIM5360 must be used together. VBAT directly supplies the power to RF PA and baseband system. For the VBAT, the ripple due to GSM/GPRS emission burst (every 4.615ms) may cause voltage drop, and the current consumption rises typically to peak of 2A. So the power supply must be able to provide sufficient current up to more than 2A. The following figure is the VBAT voltage ripple wave at the maximum power transmit phase.

The test condition: VBAT =4.0V, VBAT maximum output current =2A, $C_A=100\ \mu\text{F}$ tantalum capacitor

(ESR=0.7Ω) and $C_B=1\mu\text{F}$ (Please refer to Figure 8—Application circuit).

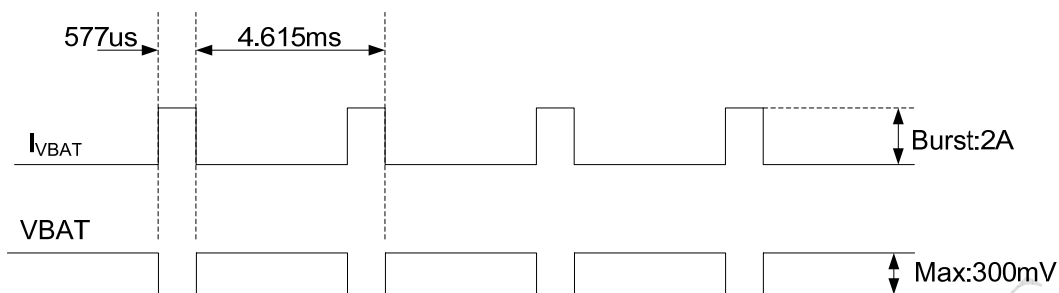

Figure 7: VBAT voltage drop during burst emission (GSM/GPRS)

3.1.1 Power Supply Pin

Two VBAT pins are dedicated to connect the supply voltage.

Table 5: Pin description

Pin type	Pin name	Min	Typ	Max	Unit
POWER	VBAT	3.4	3.8	4.2	V

Note:

1. When the module is power off, users must pay attention to the issue about current leakage. Refer to Chapter 3.10.2.

3.1.2 Design Guide

Make sure that the input voltage at the VBAT pin will never drop below 3.3V even during a transmit burst when the current consumption rises up to more than 2A. If the power voltage drops below 3.3V, the module may be shut down automatically. Using large tantalum capacitors (above 100uF) will be the best way to reduce the voltage drops. If the power current cannot support up to 2A, users must introduce larger capacitor (typical 1000uF) to storage electric power, especially GPRS multiple time slots emission.

For the consideration of RF performance and system stability, some multi-layer ceramic chip (MLCC) capacitors (0.1/1uF) need to be used for EMC because of their low ESR in high frequencies. Note that capacitors should be put beside VBAT pins as close as possible. Also User should minimize the PCB trace impedance from the power supply to the VBAT pins through widening the trace to 80 mil or more on the board. The following figure is the recommended circuit.

In addition, in order to get a stable power source, it is suggested to use a zener diode of which reverse zener voltage is 5.1V and dissipation power is more than 500mW.

Table 6: Recommended zener diode models

No.	Manufacturer	Part Number	Power	Package
1	On semi	MMSZ5231BT1G	500mW	SOD123
2	Prisemi	PZ3D4V2H	500mW	SOD323
3	Prisemi	PZ5D4V2H	500mW	SOD523
4	Vishay	MMSZ4689-V	500mW	SOD123
5	Crownpo	CDZ55C5V1SM	500mW	0805

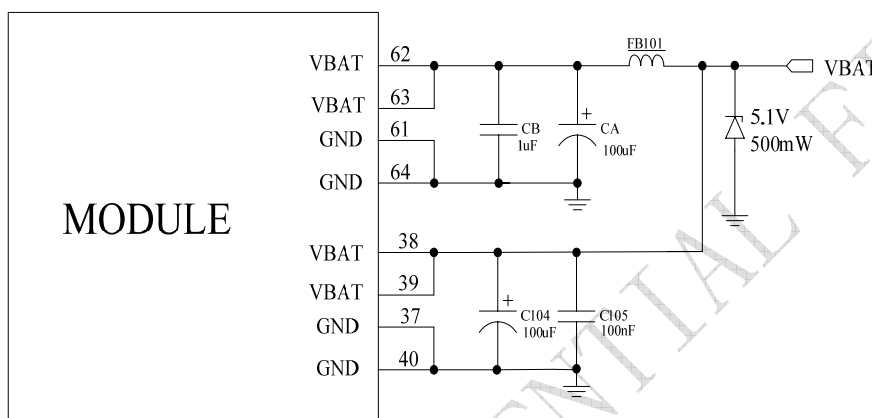

Figure 8: VBAT input application circuit

There are three sections about how to design and optimize users' power systems.

Power supply circuit

We recommend DCDC or LDO is used for the power supply of the module, make sure that the peak current of power components can rise up to more than 2A. The following figure is the reference design of +5V input power supply. The designed output for the power supply is 4.1V, here a linear regulator can be used.

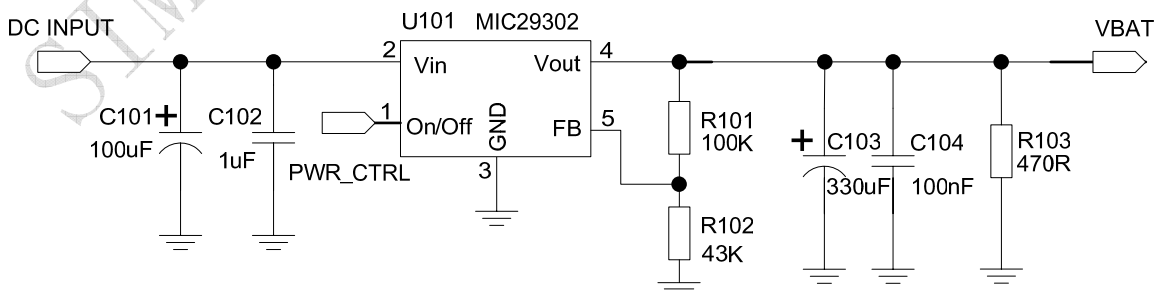

Figure 9: Reference circuit of the LDO power supply

If there is a big difference between the input voltage and the desired output (VBAT), a switching converter

power will be preferable because of its better efficiency, especially at the high current situation. The following figure is the reference circuit. Note that DCDC may deprave RF performance because of ripple current intrinsically.

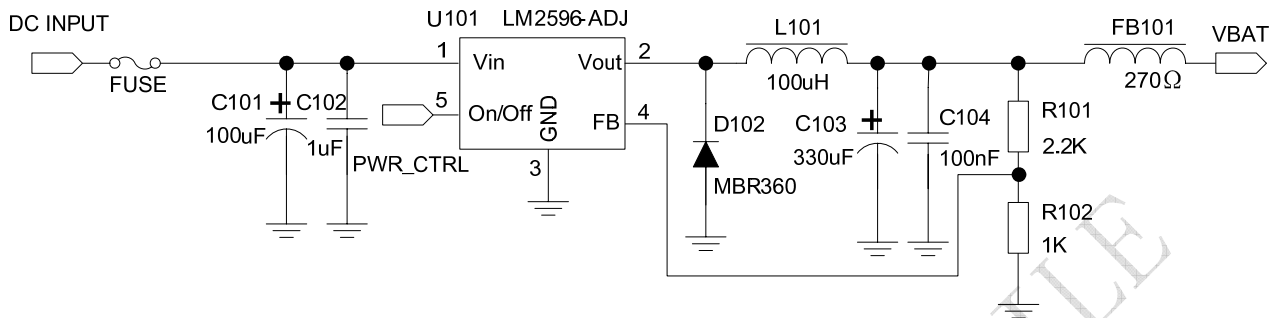

Figure 10: Reference circuit of the DCDC power supply

Voltage monitor

To monitor the power supply voltage, user can use the AT command “AT+CBC”, this command has two parameters: the battery status and the voltage value (mV). It will return the capacity percentage and actual value of battery (at the VBAT pin). The voltage is continuously measured at intervals, whenever the measured battery voltage is lower than a specific value set by the AT command “AT+CVALARM”. For example, if the voltage value is set to be 3.4V, the following URC will be presented: “warning! voltage is low: 3.3v”.

If the voltage is lower than a specific value which is set by the AT command “AT+CPMVT”, the module will be powered off automatically and AT commands cannot be executed any more.

Note: Under-voltage warning function is disabled by default, user can enable it by the AT command “AT+CVALARM”. Please refer to Document [1].

3.1.3 RTC Backup

The module uses RTC (Real Time Clock) to update and maintain inherent time and keeps system alive at no power supply status. The RTC power supply of module can be provided by an external capacitor or a battery (non-chargeable or rechargeable) through the VRTC. The following figures show various reference circuits for RTC back up. The discharge current is less than 10uA.

- External capacitor backup

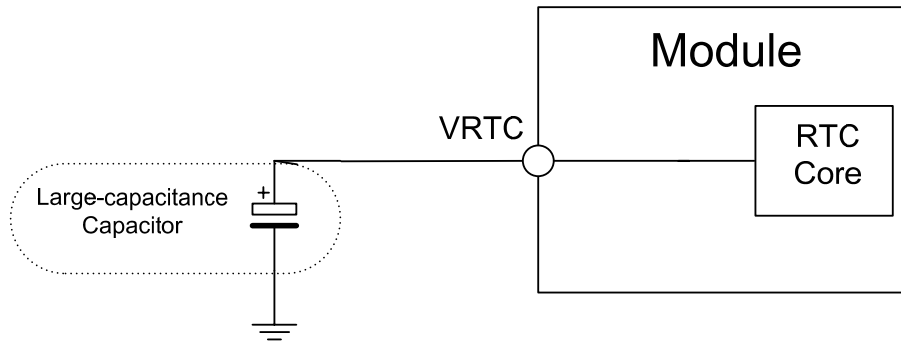

Figure 11: RTC supply from capacitor

- Non-chargeable battery backup

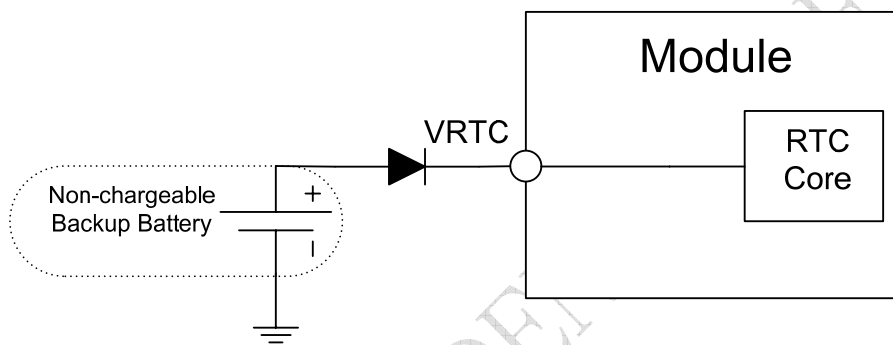

Figure 12: RTC supply from non-chargeable battery

- Rechargeable battery backup

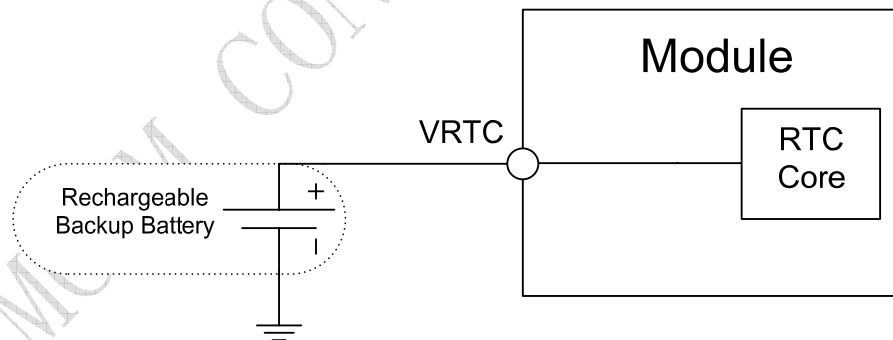

Figure 13: RTC supply from rechargeable battery

Coin-type rechargeable battery is recommended, such as ML414H-IV01E form Seiko can be used.

Note: The VRTC can be disabled, just disconnect it in application circuit.

3.2 Power on/off Time Sequence

3.2.1 Power on Sequence

SIM5360 can be powered on by POWERKEY pin, which starts normal operating mode.

POWERKEY pin is pulled up with a 200k ohm resistor to 1.8V in module. User can power on the SIM5360 by pulling the POWERKEY pin down for a short time. The power-on scenarios are illustrated in the following figures.

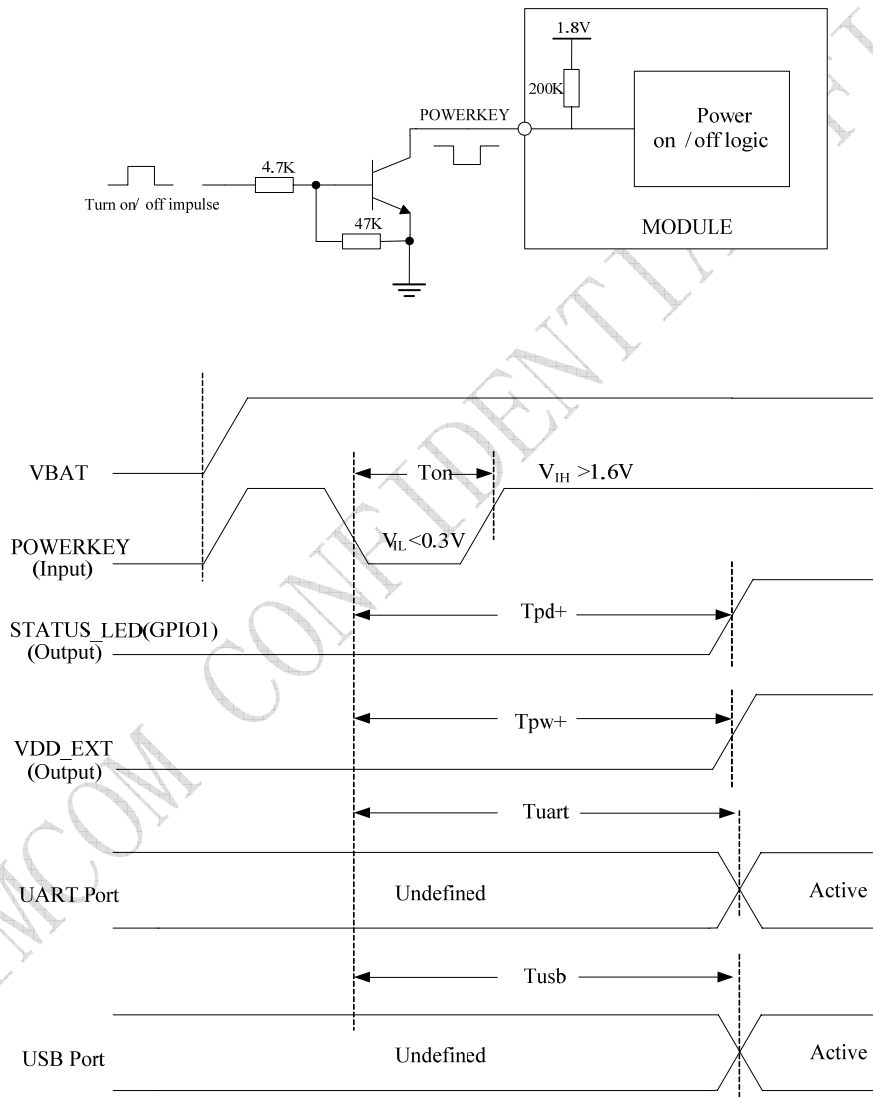

Figure 14: Power on Timing Sequence

Table 7: Power on timing

Symbol	Parameter	Time value			Unit
		Min.	Typ.	Max.	
Ton	The time to pull POWERKEY down to power on	180	500	-	ms
TpD+	The time to indicate connecting with the network	-	-	5	s
Tpw+	The time to indicate the module is powered on completely	-	-	0.5	s
Tuart	The time to enable UART	-	-	8	s
Tusb	The time to enable USB	-	-	10	s

Note: Module could be automatically power on by connecting Power ON pin to Low level directly. Before designing, please refer to Document [27] for more detail.

3.2.2 Power off Sequence

The following methods can be used to power down SIM5360. These procedures will make module disconnect from the network and allow the software to enter a safe state, and then save data before completely powering the module off.

- Method 1: Power off SIM5360 by pulling the POWERKEY pin down
- Method 2: Power off SIM5360 by AT command

User can power off the SIM5360 by pulling POWERKEY down for a specific time. The power off scenario is illustrated in the following figure.

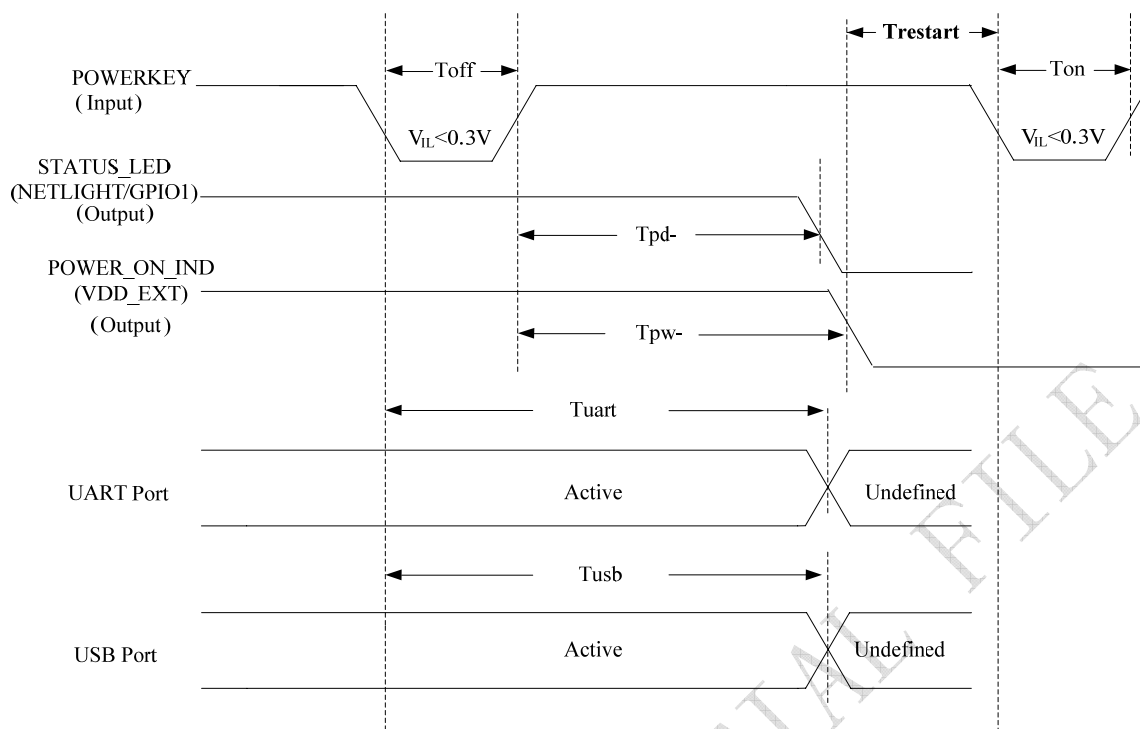

Figure 15: Power off timing sequence

Table 8: Power off timing

Symbol	Parameter	Time value			Unit
		Min.	Typ.	Max.	
T _{off}	The time pulling POWERKEY down to power off	0.5	-	5	s
T _{pd-}	The time to indicate disconnecting from the network	-	-	2	s
T _{pw-}	The time to indicate the module power off completely	-	-	2	s
T _{uart}	The time to disable UART	-	-	3	s
T _{usb}	The time to disable USB	-	-	2	s
T _{restart}	The time to power on again after T _{pw-}	0	-	-	s

User can also use the AT command “AT+CPOF” to power down the module. After that, the AT commands cannot be executed any longer. The module enters the POWER DOWN mode, only the RTC is still active. For details, refer to *Document [1]*.

3.3 UART Interface

SIM5360 provides two UARTs (universal asynchronous serial transmission) port. UART1 consists of a flexible 7-wire serial interface. UART2 consists of 2-wire serial interface. The module is as the DCE (Data

Communication Equipment) and the client PC is as the DTE (Data Terminal Equipment). AT commands are entered and serial communication is performed through UART interface.

In order to prevent the UART signals of the module damaged due to voltage spikes or ESD, series resistors can be used on UART signals.

The application circuit is in the following figures.

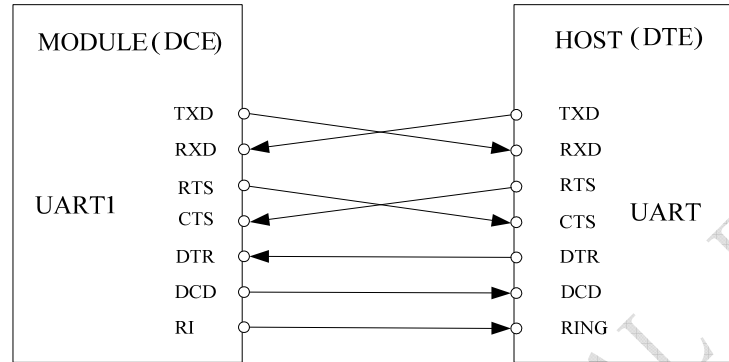

Figure 16: UART1 Full modem

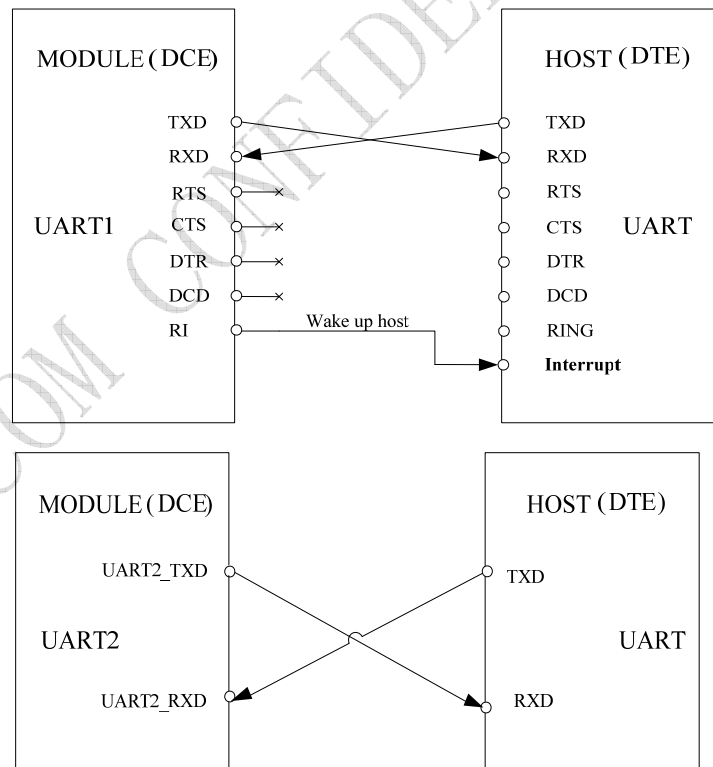

Figure 17: Null modem (UART1 and UART2)

3.3.1 Pin Description

Table 9: Pin description

Pin type	Pin name	Pin No.	I/O	Default Status
UART1	RXD	68	I	Pull-Down
	TXD	71	O	Pull-Up
	RTS	66	O	
	CTS	67	I	Pull-Up
	DTR	72	I	Pull-Up
	DCD	70	O	
	RI	69	O	
UART2	UART2_RXD	7	I	Pull-Down
	UART2_TXD	8	O	Pull-Up

More pin information refers to chapter 2.2.

Table 10: Logic level

Symbol	Parameter	Min	Typ	Max	Unit
V _{IH}	High-level input voltage	1.26	1.8	2.1	V
V _{IL}	Low-level input voltage	-0.3	0	0.63	V
V _{OH}	High-level output voltage	1.35	1.8	1.8	V
V _{OL}	Low-level output voltage	0	0	0.45	V

3.3.2 Application Guide

If UART port is used in Null Modem, the pin “RI” can be used as an interrupt signal to HOST. Normally it will keep high logic level until certain condition such as receiving SMS, voice call (CSD, video) or URC reporting, then “RI” will change to low logic level to inform the master (client PC). It will stay low until the master clears the interrupt event with AT command.

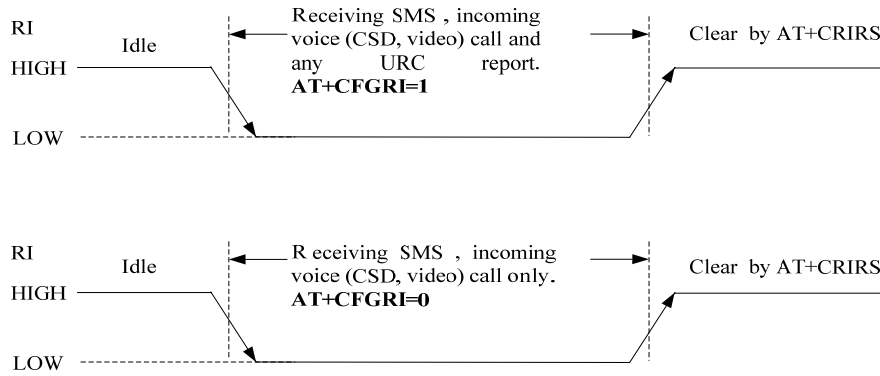

Figure 18: RI behaviour in NULL Modem

If Full Modem is used to establish communication between devices, the pin “RI” is another operation status. Initially it keeps high, when a voice call or CSD call comes, the pin “RI” will change to low for about 5900ms, then it will return to high level for 100ms. It will repeat this procedure until this call is answered or hung up.

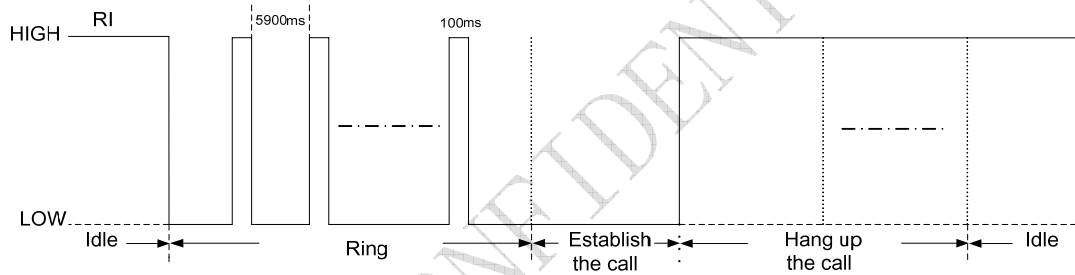

Figure 19: RI behaviour in FULL Modem

The SIM5360 UART is 1.8V interface. A level shifter should be used if user’s application is equipped with a 3.3V UART interface. The level shifter TXB0108RGYR provided by Texas Instruments is recommended. The reference design of the TXB0108RGYR is in the following figures.

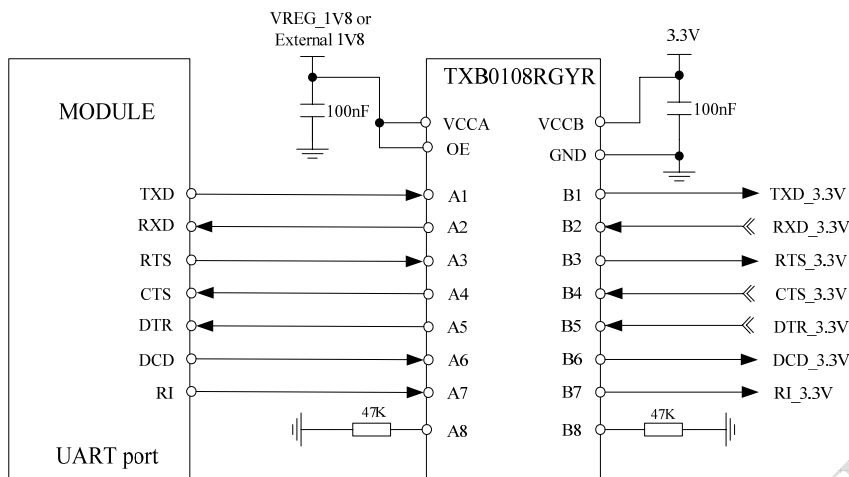

Figure 20: Reference circuit of level shift

To comply with RS-232-C protocol, the RS-232-C level shifter chip should be used to connect SIM5360 to the RS-232-C interface. In this connection, the TTL level and RS-232-C level are converted mutually. SIMCom recommends that user uses the SP3238ECA chip with a full modem. For more information please refers to the RS-232-C chip datasheet.

Note: SIM5360 supports the baud rate: 300, 600, 1200, 2400, 4800, 9600, 19200, 38400, 57600, 115200, 230400, 460800, 921600, 3200000, 3686400, 4000000bps. Default rate is 115200bps.

3.4 SD/MMC Interface

SIM5360 provides one 4-bit SD/MMC interface. Its operation voltage is 2.85V, with clock rates up to 52 MHz. It supports 1-bit SD/MMC or 4-bit SD data transmission mode. Though the same hardware controller is used, the initialization procession for SD or MMC cards is different. SIM5360 will detect which card is inserted automatically.

Note: Interface with SD/MMC memory cards up to 32GB.

3.4.1 Pin Description

Table 11: Pin description

VDD_EXT	44	SD card power
SD_DATA0	22	SD/MMC card data0
SD_DATA1	23	SD card data1
SD_DATA2	24	SD card data2
SD_DATA3	25	SD card data3
SD_CLK	26	SD card clock
SD_CMD	21	SD card command

Table 12: Electronic characteristic

Symbol	Parameter	Min	Typ	Max	Unit
VDD_EXT	LDO power output	2.71	2.85	2.99	V
V _{IH}	High-level input voltage	0.65·VDD_EXT	-	VDD_EXT+0.3	V
V _{IL}	Low-level input voltage	-0.3	0	0.3·VDD_EXT	V
V _{OH}	High-level output voltage	2.71	2.85	2.99	V
V _{OL}	Low-level output voltage	0	0	0.45	V

3.4.2 Design guide

The module provides a LDO named VDD_EXT for SD card power supply. The LDO is 2.85V by default, capable of 300mA. Data lines should be pulled up to VDD_EXT by 10K resistors. ESD/EMI components should be arranged beside SD card socket. Refer to the following application circuit.

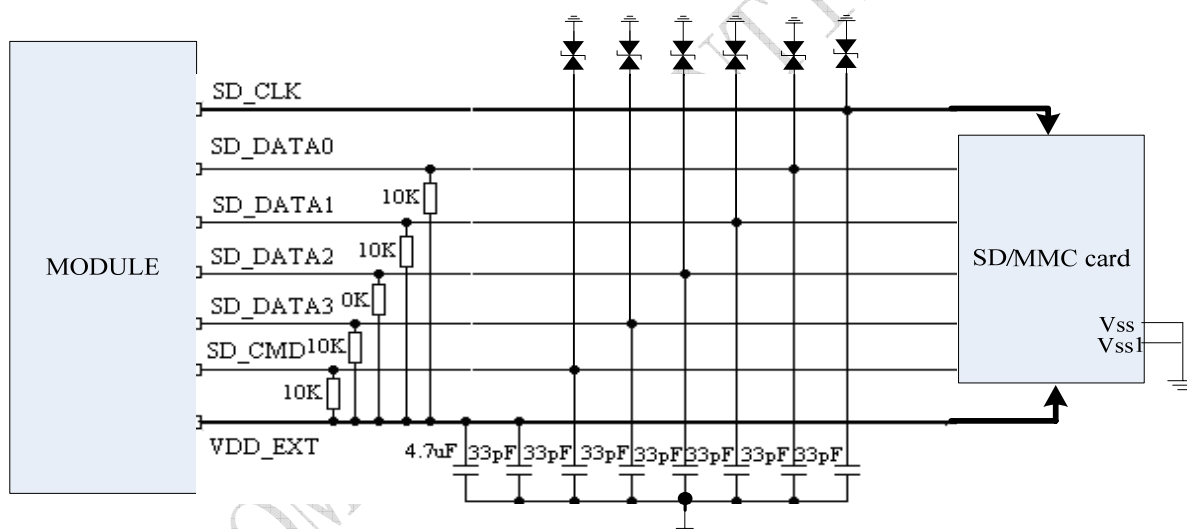
Figure 21: SD interface circuit

3.5 USIM Interface

The USIM provides the required subscription verification information to allow the mobile equipment to attach to a GSM or UMTS network. Both 1.8V and 3.0V SIM Cards are supported.

3.5.1 Pin description

Table 13: Pin description

Pin name	Pin	Description
----------	-----	-------------

USIM_CLK	19	USIM Card Clock
USIM_RST	18	USIM Card Reset
USIM_DATA	17	USIM Card data I/O, which has been pulled up with a 22kR resistor to USIM_VDD in module. Do not pull up or pull down in users' application circuit.
USIM_VDD	20	USIM Card Power output depends automatically on USIM mode, one is 3.0V±10%, another is 1.8V±10%. Current is less than 50mA.

Table 14: Electronic characteristic

Symbol	Parameter	3.0V mode			1.8V mode			Unit
		Min	Typ	Max	Min	Typ	Max	
USIM_VDD	LDO power output	2.71	2.85	3.05	1.7	1.8	1.9	V
V _{IH}	High-level input voltage	0.65·USIM_VDD	-	USIM_VDD +0.3	0.65·USIM_VDD	-	USIM_VDD +0.3	V
V _{IL}	Low-level input voltage	-0.3	0	0.3·USIM_VDD	-0.3	0	0.3·USIM_VDD	V
V _{OH}	High-level output voltage	2.71	2.85	3.05	1.7	1.8	1.9	V
V _{OL}	Low-level output voltage	0	0	0.45	0	0	0.45	V

3.5.2 Application Guide

It is recommended to use an ESD protection component such as ST (www.st.com) ESDA6V1W5 or ON SEMI (www.onsemi.com) SMF05C. Note that the SIM peripheral circuit should be close to the SIM card socket. The reference circuit of the 6-pin SIM card holder is illustrated in the following figure.

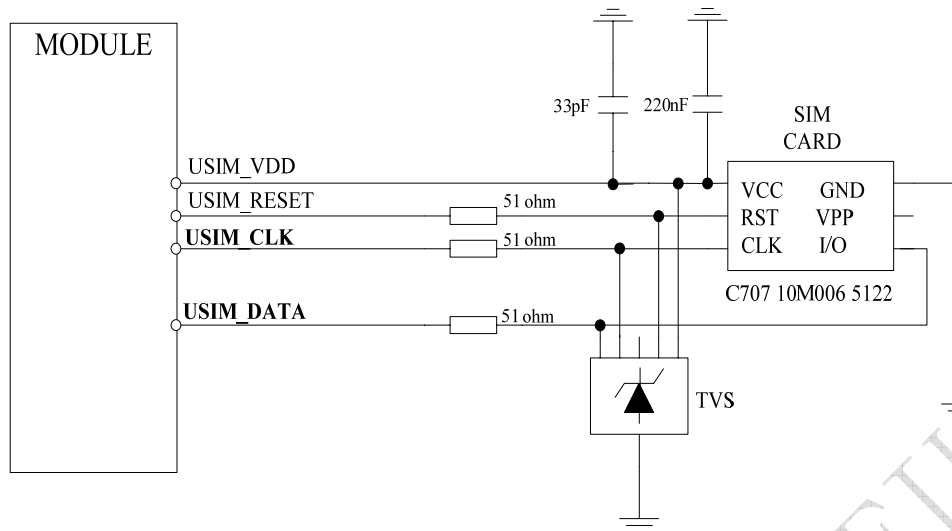

Figure 22: USIM interface reference circuit

Note: USIM_DATA has been pulled up with a 15kohm resistor to USIM_VDD in module. A 220nF shut capacitor on USIM_VDD is used to reduce interference. Use AT Commands to get information in USIM card. For more detail, please refer to document [1].

3.5.3 Recommend Components

For 6 pins USIM socket, SIMCom recommend to use Amphenol **C707 10M006 512 2**. User can visit <http://www.amphenol.com> for more information about the holder.

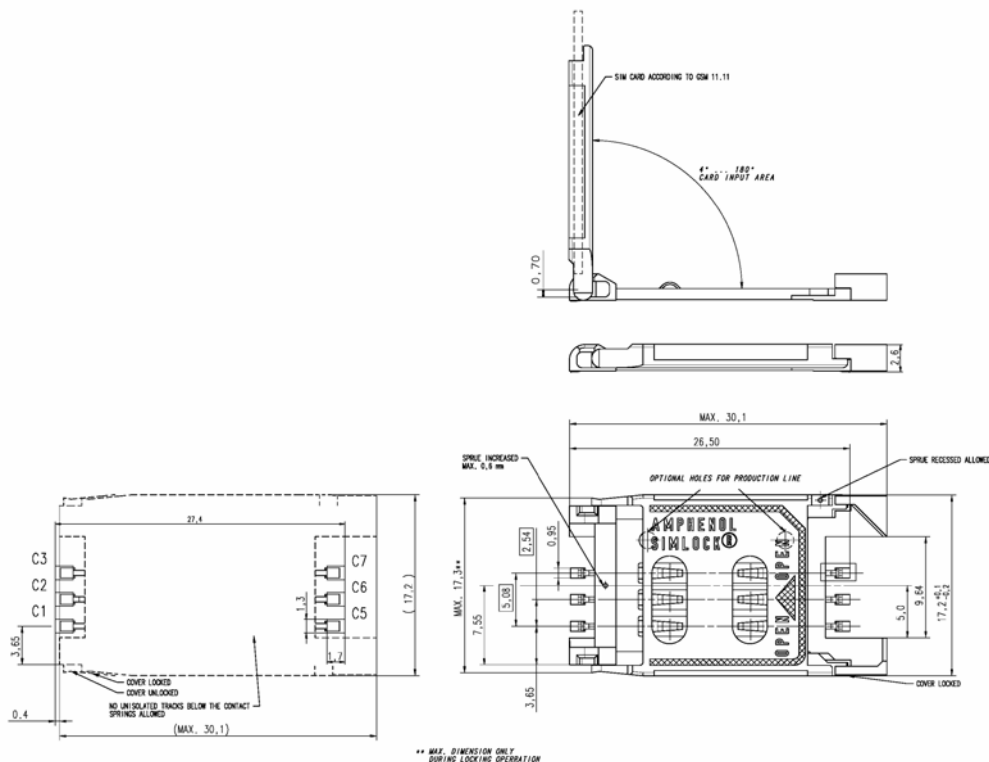

Figure 23: Amphenol SIM card socket

Table 19: Amphenol USIM socket pin description

Pin	Signal	Description
C1	USIM_VDD	SIM Card Power supply, it can identify automatically the SIM Card power mode, one is 3.0V±10%, another is 1.8V±10%.
C2	USIM_RST	SIM Card Reset.
C3	USIM_CLK	SIM Card Clock.
C5	GND	Connect to GND.
C6	VPP	
C7	USIM_DATA	SIM Card data I/O.

3.6 I2C Interface

I2C is used to communicate with peripheral equipments and can be operated as either a transmitter or receiver, depending on the device function. Use AT Commands “AT+CRIC and AT+CWIC” to read/write register values of related peripheral equipments connected with I2C interface. Its operation voltage is 1.8V.

3.6.1 Pin Description

Table 15: Pin description

Pin name	Pin No.	Function
SDA	56	Serial interface data input and output
SCL	55	Serial interface clock input

3.6.2 Signal Description

Both SDA and SCL are bidirectional lines, connected to a positive supply via a pull-up resistor respectively. When the bus is free, both lines are high.

3.6.3 Design Guide

For SIM5360, the data on the I2C bus can be transferred at rates up to 400kbps. The number of peripheral devices connected to the bus is solely dependent on the bus capacitance limit of 400pF. Note that PCB traces length and bending are in users' control to minimize load capacitance.

Note: SDA and SCL have none pulled up resistors in module. So there is need to pull them up in users' application circuit.

3.7 Keypad Interface

SIM5360 module provides a keypad interface that supports five sense lines, or columns, and five keypad rows. The interface generates an interrupt when any key is pressed. Its operation voltage is 1.8V.

3.7.1 Pin Description

Table 16: Pin description

Pin name	Pin No.	Function
KBC0	28	
KBC1	27	
KBC2	31	
KBC3	32	

KBC4	36	Driving pads
KBR0	30	
KBR1	29	
KBR2	30	
KBR3	35	
KBR4	34	

3.7.2 Application Guide

All keypad pins can be configured for GPIOs. These GPIOs also support interruption operation if used as input pins. A typical circuit about the keypad (5*5 keypad matrix) is shown in the following figure.

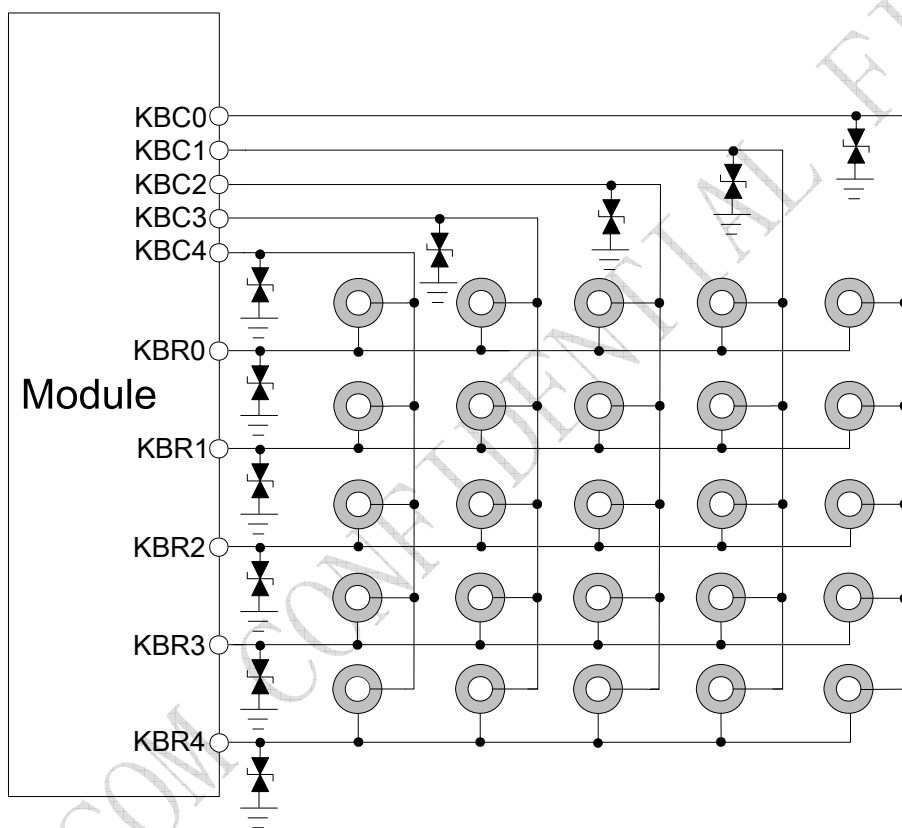

Figure 24: Reference circuit

If these pins are configured for GPIOs, the sequence is listed in the following table.

Table 17: GPIO configuration

Keypad interface	GPIO No.
KBR4	GPIO6
KBR3	GPIO7
KBR2	GPIO8
KBR1	GPIO9
KBR0	GPIO10

KBC4	GPIO11
KBC3	GPIO12
KBC2	GPIO13
KBC1	GPIO14
KBC0	GPIO15

Note: Refer to document [23] for detailed information of Keypad Application Note.

3.8 USB Interface

SIM5360 module contains a USB interface. This interface is compliant with the USB2.0 specification. The USB2.0 specification requires hosts such as the computer to support all three USB speeds, namely low-speed (1.5Mbps), full-speed (12Mbps) and high-speed (480Mbps). USB charging and USB-OTG is not supported.

Table 18: Electronic characteristic

Pin name	Pin No.	Input voltage scope(V)		
		Min	Typ	Max
USB_VBUS	11	3	5.0	5.25
USB_DP	13	They are compliant with the USB 2.0 specification.		
USB_DN	12			

3.8.1 Application Guide

Currently SIM5360 supports the USB suspend and resume mechanism which can help to save power. If no transaction is on USB bus, SIM5360 will enter suspend mode. When some events such as voice call or receiving SMS happen, SIM5360 will resume normal mode automatically.

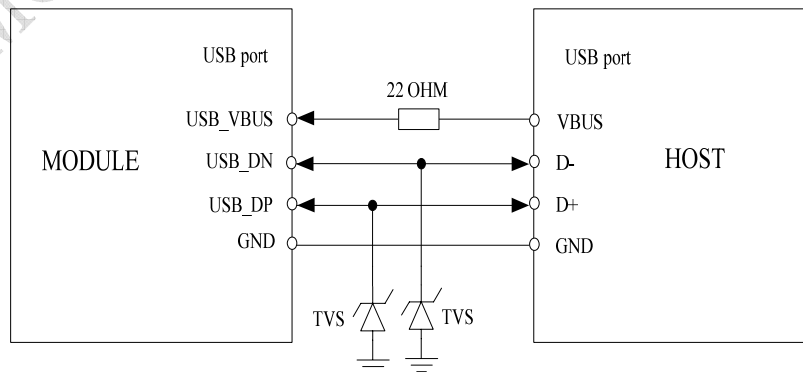

Figure 25: USB interface

Because of high bit rate on USB bus, pay attention to influence of junction capacitance of ESD component on USB data lines. Typically, the capacitance should be less than 4pF @1MHz.

It is recommended to use an ESD protection component such as ON SEMI (www.onsemi.com) ESD9M5.0ST5G or ESD9L5.0ST5G.

Note: The SIM5360 has two kinds of interface (UART and USB) to connect to host CPU. USB interface is mapped to five virtual ports: “SIMTECH HS-USB Modem 9000”, “SIMTECH HS-USB NMEA 9000”, “SIMTECH HS-USB AT port 9000”, “SIMTECH HS-USB Diagnostics 9000” and “SIMTECH Wireless HS-USB Ethernet Adapter 9000”.

3.9 SPI Interface

SPI interface of SIM5360 is master only. It provides a duplex, synchronous, serial communication link with peripheral devices. Its operation voltage is 1.8V, with clock rates up to 26 MHz.

3.9.1 Pin Description

Table 19: Pin description

Pin name	Pin No.	Function
SPI_CS	9	SPI chip-select; not mandatory in a point-to-point connection
SPI_MISO	7	SPI master in/slave out data
SPI_CLK	6	SPI clock
SPI_MOSI	8	SPI master out/slave in data

Table 20: Electronic characteristic

Symbol	Parameter	Min	Typ	Max	Unit
V _{IH}	High-level input voltage	1.26	1.8	2.1	V
V _{IL}	Low-level input voltage	-0.3	0	0.63	V
V _{OH}	High-level output voltage	1.35	1.8	1.8	V
V _{OL}	Low-level output voltage	0	0	0.45	V

3.10 GPIO Interface

SIM5360 provides a limited number of GPIO pins. All GPIOs can be configured as inputs or outputs. User can use AT Commands to read or write GPIOs status. Refer to ATC document for details.

3.10.1 Pin Description

Table 21: Pin description

Pin name	Pin No.	I/O	Function
NETLIGHT/GPIO1	51	O	Output PIN as LED control for network status. If it is unused, left open.
GPIO4	54	I	Input PIN as RF operating control. H: Normal Mode L:Flight Mode If it is unused, left open.
GPIO40	49	O	Output PIN as operating status indicating of module. H: Power on L: Power off If it is unused, left open.
GPIO41	52	I/O	General input/output PIN. It can be used as wake/interrupt signal to host from module If it is unused, left open.
GPIO42	53	I/O	General Purpose Input/Output Port.
GPIO43	50	I/O	General Purpose Input/Output Port. It can be used as wake/interrupt signal to module from host. If it is unused, left open.
GPIO44	48	I/O	General Purpose Input/Output Port

Note: If more GPIOs need to be used, users can configure GPIO on other multiple function interfaces, such as PCM. Please refer to GPIO list.

Table 22: Electronic characteristic

Symbol	Parameter	Min	Typ	Max	Unit
V _{IH}	High-level input voltage	1.26	1.8	2.1	V
V _{IL}	Low-level input voltage	-0.3	0	0.63	V
V _{OH}	High-level output voltage	1.35	1.8	1.8	V
V _{OL}	Low-level output voltage	0	0	0.45	V

Note: The output driver current of GPIOs is 2mA.

3.10.2 Application Guide

Network status

GPIO1 is used to control Network Status LED; application circuit is shown below.

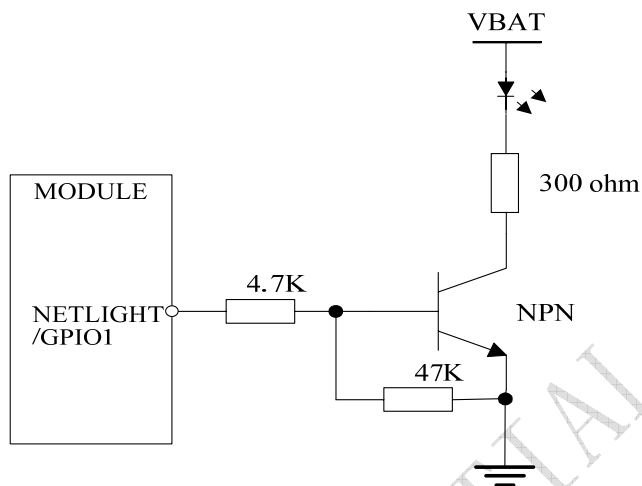

Figure 26: Application circuit

Note: The value of resistor Rx depends on LED characteristic.

Table 23: LED status

LED Status	Module Status
Always On	Searching Network/Call Connect
200ms ON, 200ms OFF	Data Transmit
800ms ON, 800ms OFF	Registered network
Off	Power off / Sleep

Flight mode control

GPIO4 controls SIM5360 module to enter or exit the Flight mode. In Flight mode, SIM5360 closes RF function to prevent interference with other equipments or minimize current consumption. Bidirectional ESD protection component is suggested to add on GPIO4.

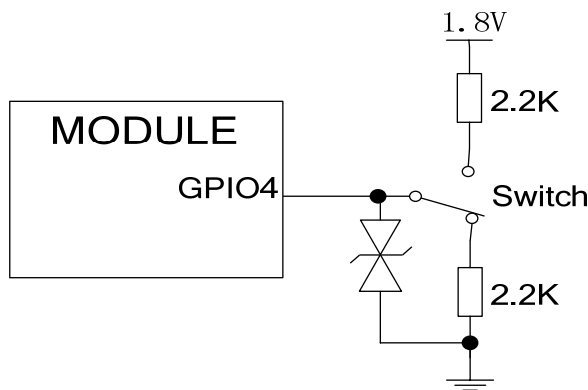

Figure 27: Flight mode switch

Table 24: Control status

GPIO4 Status	Module operation
Low Level	Flight Mode: RF is closed.
High Level	Normal Mode: RF is working.

Note: 1. For SIM5360, GPIO0, GPIO2, GPIO3 and GPIO5 have multiplex function, user can use them as PCM interface to connect extend codec. Refer to section 3.11 and document [1] for details.

2. When the module is powered off, make sure all digital interfaces (PCM UART, etc) connected with peripheral devices have no voltage higher than 0.3V. If users' design cannot meet above conditions, high level voltages maybe occur in GPIO pins because current leakage from above digital interfaces may occur.

3.11 PCM Interface

SIM5360 provides hardware PCM interface for external codec. The PCM interface enables communication with an external codec to support hands-free applications. SIM5360 PCM interface can be used in two modes: the default mode is auxiliary PCM (8 KHz long sync mode at 128 KHz PCM CLK); the other mode is primary PCM (8 KHz short sync mode at 2048 KHz PCM CLK). In short-sync (primary PCM) mode, SIM5360 can be a master or a slave. In long-sync (auxiliary PCM) mode, SIM5360 is always a master. SIM5360 also supports 3 kinds of coding formats: 8 bits (u-law or A-law) and 16 bits (linear).

Note: PCM interface is multiplexed from GPIO (default setting). The AT command “AT+CPCM” is used to switch between PCM and GPIO functions. Please refer to document [21] and document [1] for details.

3.11.1 Pin Description

Table 25: Pin description

Pins	Pin No.	Description
PCM_OUT	73	PCM data output
PCM_IN	74	PCM data input
PCM_SYNC	75	PCM data synchrony
PCM_CLK	76	PCM data clock

Table 26: Electronic characteristic

Symbol	Parameter	Min	Typ	Max	Unit
V _{IH}	High-level input voltage	1.26	1.8	2.1	V
V _{IL}	Low-level input voltage	-0.3	0	0.63	V
V _{OH}	High-level output voltage	1.35	1.8	1.8	V
V _{OL}	Low-level output voltage	0	0	0.45	V

3.11.2 Signal Description

The default PCM interface in SIM5360 is the auxiliary PCM interface. The data changes on the high level of PCM_CLK and is sampled at the falling edge of PCM_CLK in one period. Primary PCM is disabled after every power-on or every reset event. So user must use AT command to enable the primary PCM mode after powering on or resetting the module every time if user wants to use Primary PCM. SIM5360 PCM Interface can be operated in Master or Slave mode if it is configured to primary PCM. In Master Mode, the Module drives the clock and sync signals that are sent to the external codec. When it is in Slave Mode, the external codec drives the clock and sync signals which are sent to the module. Both PCM modes are discussed in this section followed by additional PCM topics.

Auxiliary PCM (128 KHz PCM clock)

u-law coding is supported by the auxiliary PCM. The auxiliary codec port operates with standard long-sync timing and a 128 KHz clock. The AUX_PCM_SYNC runs at 8 KHz with 50% duty cycle. Most u-law codec support the 128 KHz clock.



Figure 28: Synchrony timing

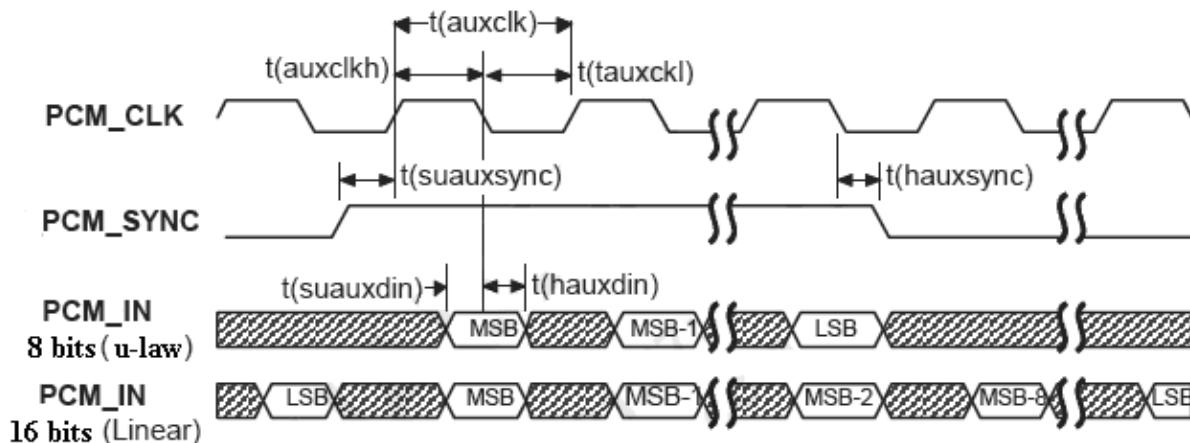

Figure 29: EXT CODEC to MODULE timing

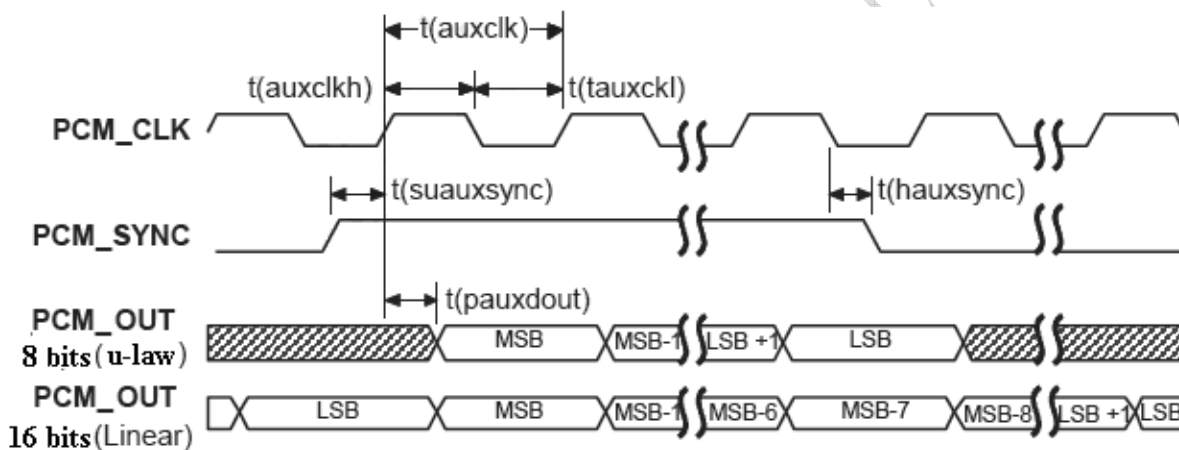

Figure 30: MODULE to EXT CODEC timing

Table 27: Timing parameters

Parameter	Description	Min	Typ	Max	Unit
T(auxsync)	AUX_PCM_SYNC cycle time	-	125	-	μs
T(auxsynch)	AUX_PCM_SYNC high time	62.4	62.5	-	μs
T(auxsyncl)	AUX_PCM_SYNC low time	62.4	62.5	-	μs
T(auxclk)*	AUX_PCM_CLK cycle time	-	7.8	-	μs
T(auxclkh)	AUX_PCM_CLK high time	3.8	3.9	-	μs
T(auxclkl)	AUX_PCM_CLK low time	3.8	3.9	-	μs
T(suauxsync)	AUX_PCM_SYNC setup time high before falling edge of PCM_CLK	1.95	-	-	μs
T(hauxsync)	AUX_PCM SYNC hold time after falling edge	1.95	-	-	μs

	of PCM_CLK				
T(suauxdin)	AUX_PCM_IN setup time before falling edge of AUX_PCM_CLK	70	-	-	ns
T(hauxdin)	AUX_PCM_IN hold time after falling edge of AUX_PCM_CLK	20	-	-	ns
T(pauxdout)	Delay from AUX_PCM_CLK rising to AUX_PCM_OUT valid	-	-	50	ns

*Note: T(auxclk) = 1/(128 KHz).

Primary PCM (2048 KHz PCM clock)

SIM5360 also supports 2.048 MHz PCM data and sync timing for u-law codec. This is called the primary PCM interface. User can use AT command to take the mode you want as discussed above.

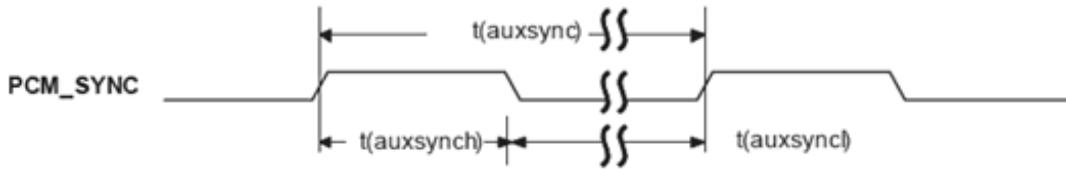

Figure 31: Synchrony timing

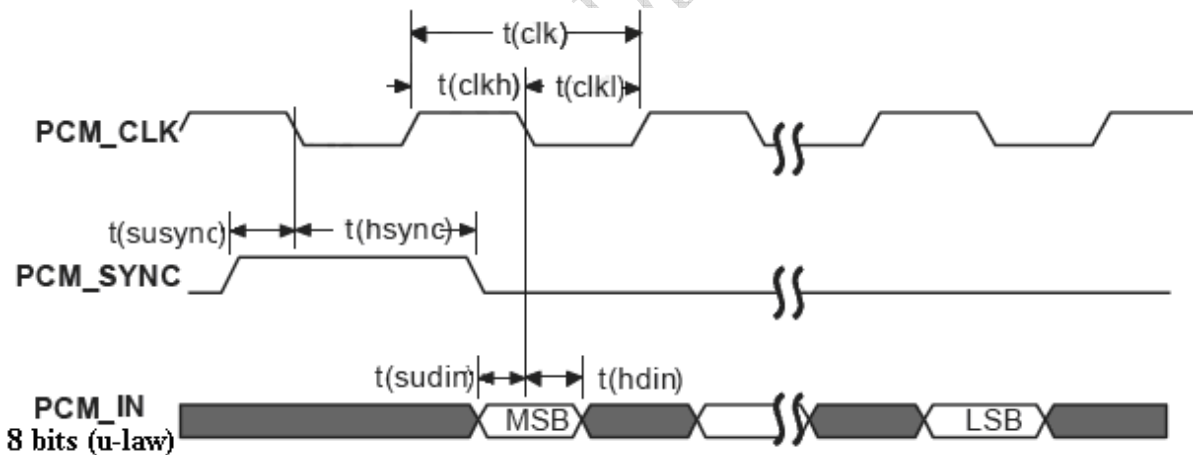

Figure 32: EXT CODEC to MODULE timing

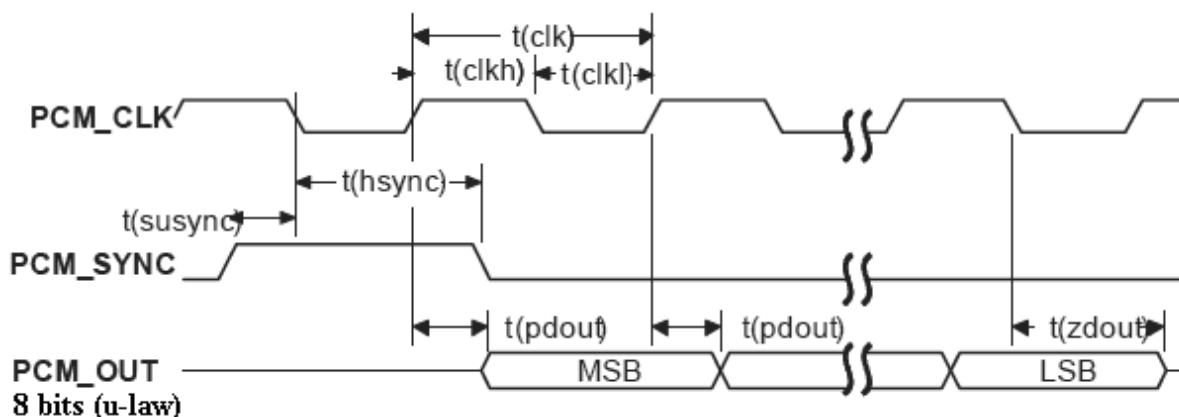

Figure 33: MODULE to EXT CODEC timing

Table 28: Timing parameters

Parameter	Description	Min	Typ	Max	Unit
T(sync)	PCM_SYNC cycle time	–	125	–	μs
T(sync _h)	PCM_SYNC high time	400	500	–	ns
T(sync _l)	PCM_SYNC low time	–	124.5	–	μs
T(clk)	PCM_CLK cycle time	–	488	–	ns
T(clk _h)	PCM_CLK high time	–	244	–	ns
T(clk _l)	PCM_CLK low time	–	244	–	ns
T(susync)	PCM_SYNC setup time high before falling edge of PCM_CLK	60	–	–	ns
T(hsync)	PCM_SYNC hold time after falling edge of PCM_CLK	60	–	–	ns
T(sudin)	PCM_IN setup time before falling edge of PCM_CLK	50	–	–	ns
T(hdin)	PCM_IN hold time after falling edge of PCM_CLK	10	–	–	ns
T(pdout)	Delay from PCM_CLK rising to PCM_OUT valid	–	–	350	ns
T(zdout)	Delay from PCM_CLK falling to PCM_OUT HIGH-Z	–	160	–	ns

Note: SIM5360 can transmit PCM data by USB except for PCM interface.

3.11.3 Application Guide

The mode of SIM5360 PCM can be configured by AT command “AT+CPCM and AT+CPCMFMT”, and the default configuration is master mode using short sync data format with 2.048MHz PCM_CLK and 8 kHz PCM_SYNC. Please refer to document [21] and document [1] for details.

In addition, the firmware of SIM5360 has integrated the configuration on WM8960GEFL/RV codec provided by WOLFSON MICROELECTRONICS with I2C interface.

The reference circuit of the reference design of PCM interfaces with external codec IC in the following figure. It is recommended to use a 26MHz CXO component such as TXC CORPORATION (www.txccorp.com) 8W26000011.

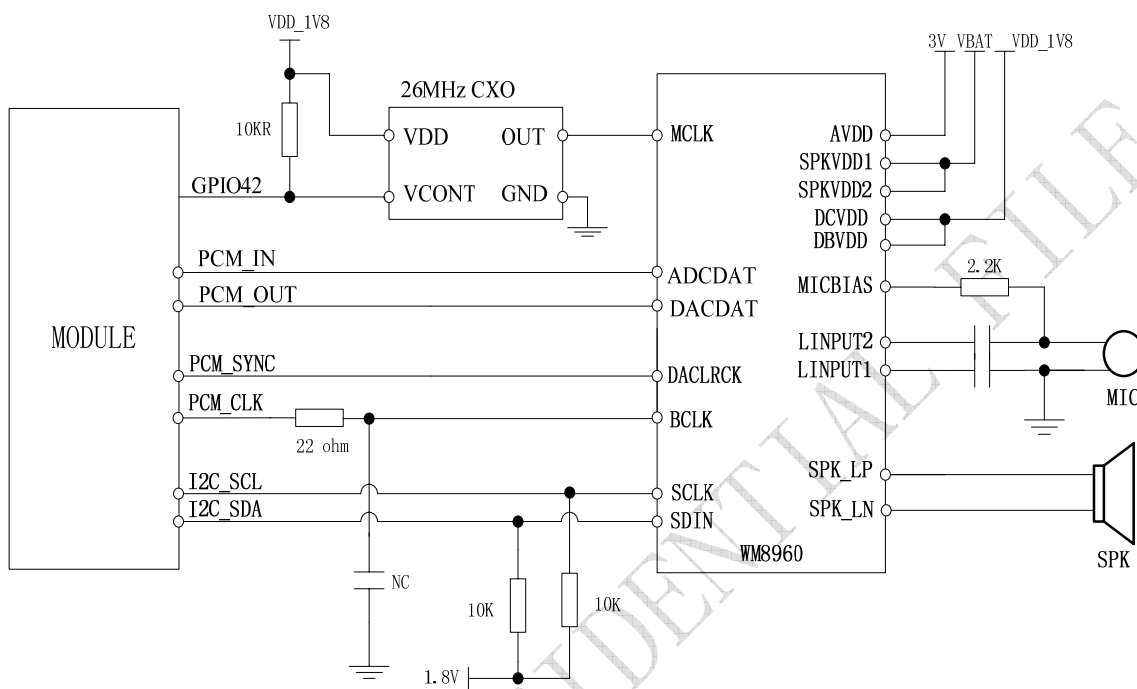

Figure 34: Reference Circuit of PCM Application with Audio Codec

3.12 GNSS (GPS and GLONASS)

SIM5360 merges GNSS (GPS/GLONASS) satellite and network information to provide a high-availability solution that offers industry-leading accuracy and performance. This solution performs well, even in very challenging environmental conditions where conventional GNSS receivers fail, and provides a platform to enable wireless operators to address both location-based services and emergency mandates.

3.12.1 Technical specification

Tracking sensitivity	-159 dBm (GPS)	-158 dBm (GLONASS)
Cold-start sensitivity	-148 dBm	
Accuracy (Open Sky)	2.5m (CEP50)	
TTFB (Open Sky)	Hot start <1s	Cold start 35s
Receiver Type	16-channel, C/A Code	
	GPS L1 Frequency (1575.42±1.023MHz),	
	GLONASS: 1597.5~1605.8 MHz	
Update rate	Default 1 Hz	
GNSS data format	NMEA-0183	

GNSS Current consumption (WCDMA/GSM Sleep mode)	100mA (Total supply current)
GNSS antenna	Passive/Active antenna

Note: Performance will vary depending on the environment, antenna type and signal conditions and so on.

3.12.2 Operate Mode

SIM5360 supports both A-GPS and S-GPS, and then provides three operating modes: mobile-assisted mode, mobile-based mode and standalone mode. A-GPS includes mobile-assisted and mobile-based mode.

In mobile-assisted mode, when a request for position location is issued, available network information is provided to the location server (e.g. Cell-ID) and assistance is requested from the location server. The location server sends the assistance information to the handset. The handset/mobile unit measures the GNSS observables and provides the GNSS measurements along with available network data (that is appropriate for the given air interface technology) to the location server. The location server then calculates the position location and returns results to the requesting entity.

In mobile-based mode, the assistant data provided by the location server encompasses not only the information required to assist the handset in measuring the satellite signals, but also the information required to calculate the handset's position. Therefore, rather than provide the GNSS measurements and available network data back to the location server, the mobile calculates the location on the handset and passes the result to the requesting entity.

In standalone (autonomous) mode, the handset demodulates the data directly from the GNSS satellites. This mode has some reduced cold-start sensitivity, and a longer time to first fix as compared to the assisted modes. However, it requires no server interaction and works out of network coverage.

This combination of GNSS measurements and available network information provides:

- High-sensitivity solution that works in all terrains: Indoor, outdoor, urban, and rural
- High availability that is enabled by using both satellite and network information

Therefore, while network solutions typically perform poorly in rural areas and areas of poor cell geometry/density, and while unassisted, GNSS-only solutions typically perform poorly indoors. The SIM5360 GNSS solution provides optimal time to fix, accuracy, sensitivity, availability, and reduced network utilization in both of these environments, depending on the given condition.

3.12.3 Application Guide

Users can adopt an active antenna or a passive antenna as GNSS signal transceiver. In this document, all GNSS specification mentioned is from passive antenna. The following is the reference circuit.

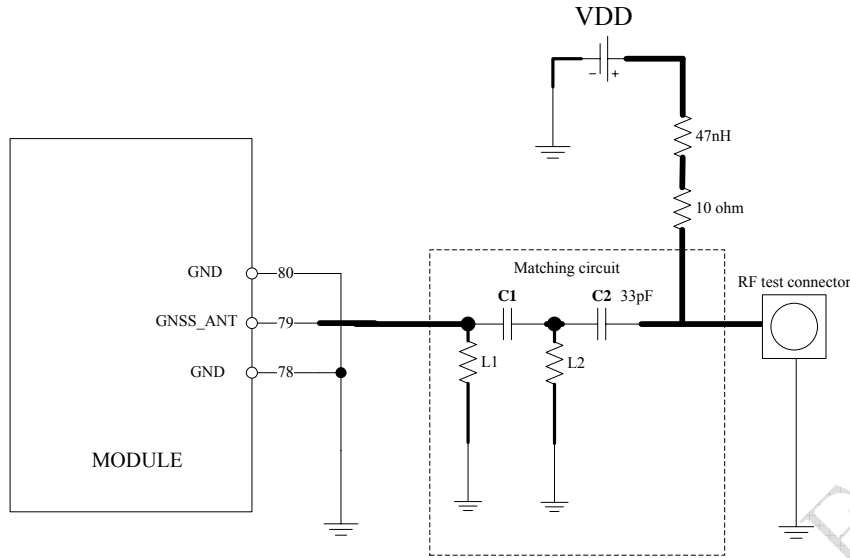

Figure 35: Active antenna circuit

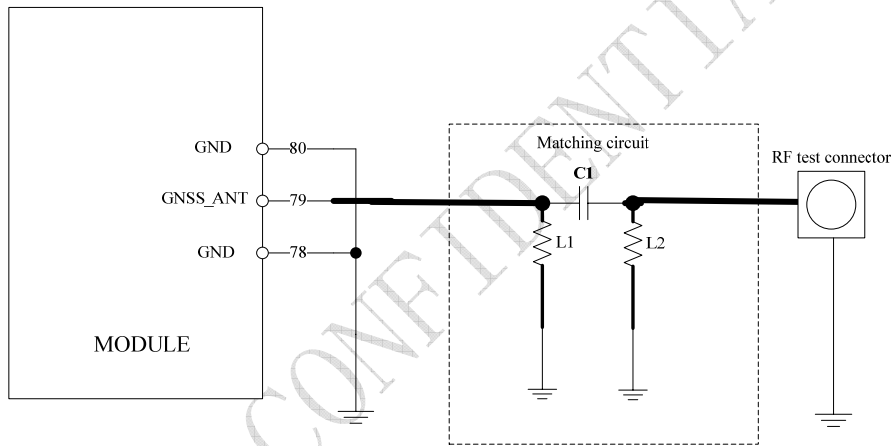

Figure 36: Passive antenna circuit (Default)

In above figures, the components C1 and L1, L2 are used for antenna matching, the values of the components can only be obtained after the antenna tuning usually, and they are provided by antenna vendor. C2 in Figure 36 is used for DC isolation. In active antenna circuit, users must use an external LDO/DCDC to provide VDD voltage whose value should be taken according active antenna characteristic, and VDD can be shut down to avoid consuming additional current when not being used.

GNSS can be used by NMEA port. User can select NMEA as output through UART or USB. NMEA sentences are automatic and no command is provided. NMEA sentences include GSV, GGA, RMC, GSA, and VTG. Before using GNSS, user should configure SIM5360 in proper operating mode by AT command. Please refer to related document for details. SIM5360 can also get position location information through AT directly.

Note: GNSS is closed by default, it could be started by AT+CGPS. The AT command has two parameters, the first is on/off, and the second is GNSS mode. Default mode is standalone mode.

AGPS mode needs more support from the mobile telecommunication network. Refer to AGPS application document for details.

3.13 Multi-functional interface

SIM5360 merges functions for various applications. It can enrich users’ design and lower the cost of users’ hardware.

3.13.1 Sink Current Source

The dedicated pin (ISINK) is intended for driving passive devices, such as LCD backlight, this implementation is VBAT tolerant and suitable for driving white LEDs. The high-current driver can maintain a constant current which is set by *the AT command “AT+ CLEDITST”*, capable of up to 40 mA.

Table 29: Electronic characteristic

Symbol	Description	Min	Typ	Max	Unit
ISINK	Input voltage	0.5	VDD	VBAT	V
I _O	Input current	5	-	40	mA

Since the driver is ground-referenced current sink, the operating device it drives must form a current path between the VDD pin and the ISINK pin. The following figure is for users reference.

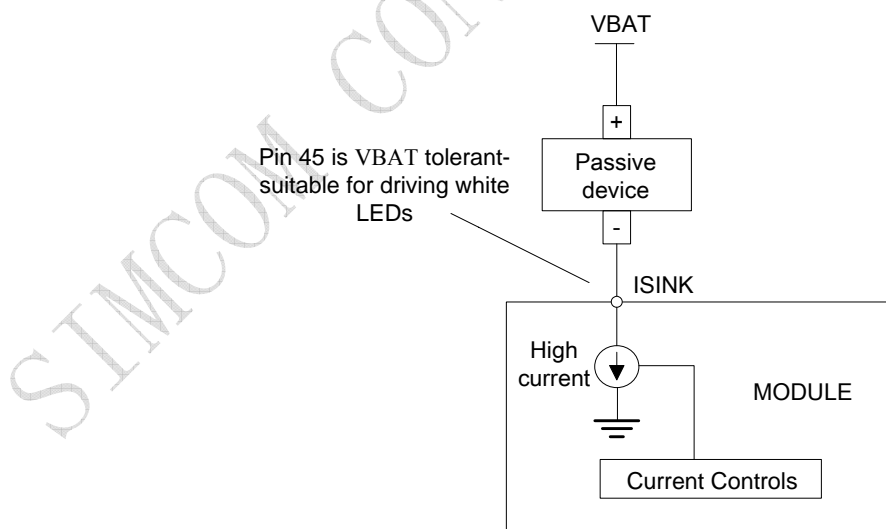

Figure 37: Current drive

Note: The sinking current can be adjusted to meet design requirement through the AT command “AT+ CLEDITST =<0>, <value>”.The “value” ranges from 0 to 15,on behalf of the current changes from 0mA to 150mA in steps of 10mA.

3.13.2 Reset Function

SIM5360 also have a RESET pin (PIN4) to reset the module. This function is used as an emergency reset only when AT command “AT+CPOF” and the POWERKEY pin has no effect. User can pull the RESET pin to ground, then the module will reset.

This pin is already pulled up in module, so the external pull-up resistor is not necessary. A 100nF capacitor close to the RESET pin is strongly recommended. A reference circuit is recommended in the following figure.

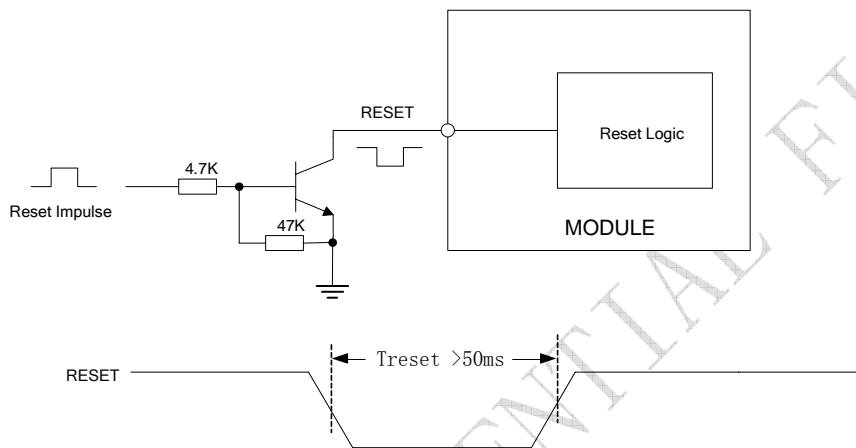

Figure 38: Reset circuit

Note : $50ms < T_{reset} < 200ms$. ESD components are suggested to be used on Reset pin.

3.13.3 ADC

SIM5360 has a dedicated ADC that is available for digitizing analog signals such as battery voltage and so on; it is on PIN 47 and PIN 46 , namely ADC1 and ADC2 . This ADC is 15 bit successive-approximation circuit, and electronic specification is shown in the following table.

Table 30: Electronic Characteristics

Specification	Min	Typ	Max	Unit	Comments/Conditions
Resolution		15		Bits	
Analog input bandwidth	-	100	-	kHz	Analog Vdd = ADC reference 2.4MHz sample rate
Gain Error	-2.5		+2.5	%	
Offset Error	-3.5		+3.5	LSB	
Input Range	GND		2.2V	V	
Input serial resistance		2		kΩ	Sample and hold switch resistance
Power supply current Normal operation		1.5		mA	
Power supply current Off		50	200	nA	

User can introduce a signal in the ADC pin directly and use the AT command “AT+CADC” to get the raw

data which is between 0 and 32768. The data can be transformed to any type such as voltage, temperature etc. Please refer to *document [1]*.

Note: *The input signal voltage value in ADC must not be higher than 2.2V.*

3.13.4 LDO

SIM5360 has a LDO power output, namely VDD_EXT. The LDO is available and output voltage is 2.85v by default, rated for 300mA. User can switch the LDO on or off by the AT command “AT+CVAUXS” and configure its output voltage by the AT command “AT+CVAUXV”.

Table 31: Electronic characteristic

Symbol	Description	Min	Typ	Max	Unit
VDD_EXT	Output voltage	1.5	2.85	3.05	V
I _O	Output current	-	-	300	mA

4 RF Specification

4.1 RF Specification

Table 32: Conducted transmission power

Frequency	Max	Min
GSM850	33dBm \pm 2dB	5dBm \pm 5dB
E-GSM900	33dBm \pm 2dB	5dBm \pm 5dB
DCS1800	30dBm \pm 2dB	0dBm \pm 5dB
PCS1900	30dBm \pm 2dB	0dBm \pm 5dB
GSM850 (8-PSK)	27dBm \pm 3dB	5dBm \pm 5dB
E-GSM900 (8-PSK)	27dBm \pm 3dB	5dBm \pm 5dB
DCS1800 (8-PSK)	26dBm +3/-4dB	0dBm \pm 5dB
PCS1900(8-PSK)	26dBm +3/-4dB	0dBm \pm 5dB
WCDMA 2100	24dBm +1/-3dB	-56dBm \pm 5dB
WCDMA 1900	24dBm +1/-3dB	-56dBm \pm 5dB
WCDMA 850	24dBm +1/-3dB	-56dBm \pm 5dB
WCDMA 900	24dBm + 1/-3dB	-56dBm \pm 5dB

Table 33: Operating frequencies

Frequency	Receiving	Transmission
GSM850	869 ~894 MHz	824 ~849 MHz
E-GSM900	925 ~960 MHz	880 ~915 MHz
DCS1800	1805~1880 MHz	1710~1785 MHz
PCS1900	1930~1990 MHz	1850~1910 MHz
WCDMA 2100	2110~2170 MHz	1920~1980 MHz
WCDMA 1900	1930~1990 MHz	1850~1910 MHz
WCDMA 850	869 ~894 MHz	824 ~849 MHz
WCDMA 900	925 ~960 MHz	880 ~915 MHz

Table 34: Conducted receive sensitivity

Frequency	Receive sensitivity
GSM850	< -109dBm
E-GSM900	< -109dBm
DCS1800	< -109dBm
DCS1800	< -109dBm
WCDMA 2100	< -110dBm
WCDMA 1900	< -110dBm

WCDMA 850	< -110dBm
WCDMA 900	< -110dBm

4.2 Operating Specification

SIM5360 can support high rate data by GSM/WCDMA wireless network. In the different network environment, data transmission rate shifts depending on modulation and encoding.

Table 35: GPRS/EDGE data throughput

Function	Coding schemes	1 Timeslot	2 Timeslot	4 Timeslot
GPRS	CS-1	9.05kbps	18.1kbps	36.2kbps
	CS-2	13.4kbps	26.8kbps	53.6kbps
	CS-3	15.6kbps	31.2kbps	62.4kbps
	CS-4	21.4kbps	42.8kbps	85.6kbps
EDGE	MCS-1	8.80kbps	17.6kbps	35.20kbps
	MCS-2	11.2kbps	22.4kbps	44.8kbps
	MCS-3	14.8kbps	29.6kbps	59.2kbps
	MCS-4	17.6kbps	35.2kbps	70.4kbps
	MCS-5	22.4kbps	44.8kbps	89.6kbps
	MCS-6	29.6kbps	59.2kbps	118.4kbps
	MCS-7	44.8kbps	89.6kbps	179.2kbps
	MCS-8	54.4kbps	108.8kbps	217.6kbps
	MCS-9	59.2kbps	118.4kbps	236.8kbps

Table 36: HSDPA throughput

Category	Supported	Max supported HS-DSCH codes	Theoretical max peak rate(Mbps)	Modulation
Category1		5	1.2	16QAM,QPSK
Category2		5	1.2	16QAM,QPSK
Category3		5	1.8	16QAM,QPSK
Category4		5	1.8	16QAM,QPSK
Category5	✓	5	3.6	16QAM,QPSK
Category6	✓	5	3.6	16QAM,QPSK
Category7	✓	10	7.2	16QAM,QPSK
Category8	✓	10	7.2	16QAM,QPSK
Category9		15	10.0	16QAM,QPSK
Category10	✓	15	14.0	16QAM,QPSK
Category11		5	0.9	QPSK
Category12	✓	5	1.8	QPSK

Note: Actual throughput rates depend on network configuration, network loading, signal condition and

so on.

4.3 Antenna Design Guide

SIM5360 provides RF antenna interface. Customer's antenna should be located in the host board and connected to module's antenna pad through micro-strip line or other types of RF trace and the trace impedance must be controlled in 50Ω. SIMCom recommends that the total insertion loss between the antenna pad and antenna should meet the following requirements:

- GSM900/GSM850<0.5dB
- DCS1800/PCS1900 <0.9dB
- WCDMA 2100/1900<0.9dB
- WCDMA 900/850<0.5dB

To facilitate the antenna tuning and certification test, a RF connector and an antenna matching circuit should be added. The following figure is the recommended circuit.

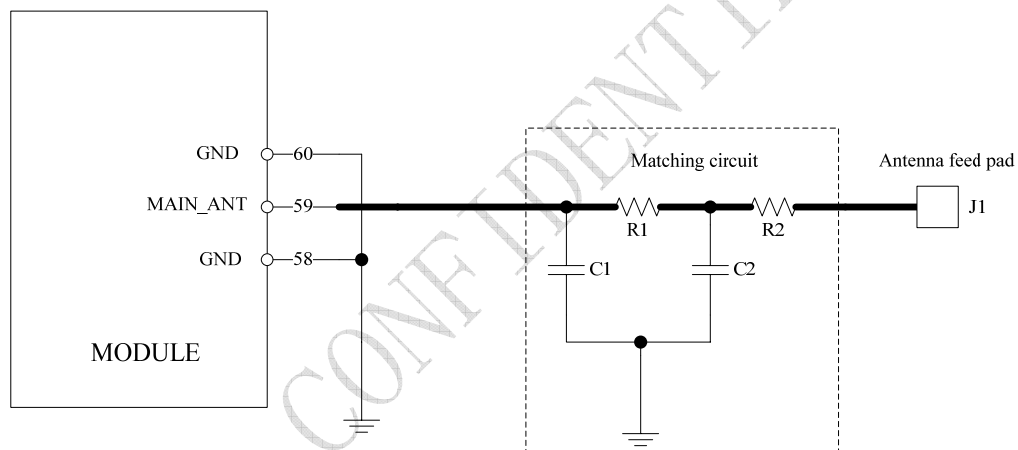

Figure 39: Antenna matching circuit (MAIN_ANT)

In this figure, the components R1,C1,C2 and R2 is used for antenna matching, the value of components can only be got after the antenna tuning, usually, they are provided by antenna vendor. By default, the R1, R2 are 0 ohm resistors, and the C1, C2 are reserved for tuning.

The RF test connector in the figure is used for the conducted RF performance test, and should be placed as close as to the module's antenna pin. The traces impedance between components must be controlled in 50ohm.

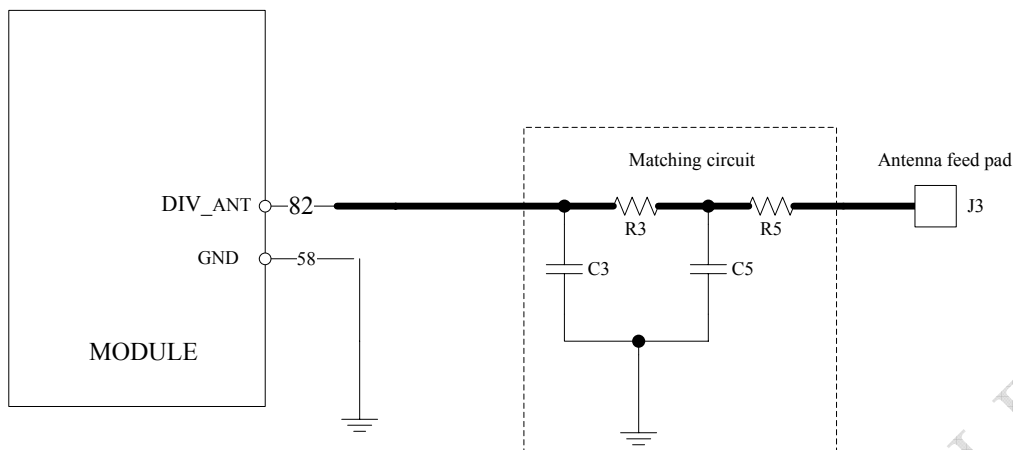

Figure 40: Antenna matching circuit (DIV_ANT)

In above figure, the components R3,C3,C5 and R5 is used for diversity antenna matching. The method of antenna tuning is same as MAIN_ANT.

5 Reliability and Operating Characteristics

5.1 Electronic Characteristics

Absolute maximum rating for digital and analog pins of SIM5360 are listed in the following table:

Table 37: Absolute maximum ratings

Parameter	Min	Max	Unit
Voltage at digital pins (1.8v digital I/O)	-0.3	2.1	V
Voltage at VBAT	-0.5	6.0	V
Voltage at VRTC	2	3.25	V
Voltage at USB_VBUS	-0.5	6.0	V

Table 38: Recommended operating ratings

Parameter	Min	Typ	Max	Unit
Voltage at digital pins (1.8v digital I/O)	0	1.8	1.95	V
Voltage at VBAT	3.4	3.8	4.2	V
Voltage at VRTC	2	-	3.2	V
Voltage at USB_VBUS	3	5	5.25	V

The operating temperature and power specification is listed in the following table.

Table 39: Operating temperature

Parameter	Min	Typ	Max	Unit
-----------	-----	-----	-----	------

Normal operation temperature	-30	25	80	°C
Extended operation temperature	-40	25	85	°C
Storage temperature	-45	25	+90	°C

Note: SIMCom recommends user to install a heat sink on the module shielding case if SIM5360 operates in WCDMA band.

5.2 Operating Mode

The following table summarizes the various operating modes, each operating modes will be referred to in the following chapters.

5.2.1 Operating Modes Overview

Table 40: Operating Modes Overview

Mode	Function	
Sleep mode	GSM/WCDMA SLEEP	Module will automatically enter SLEEP mode if DTR is set to high level and there is no on air or hardware interrupt (such as GPIO interrupt or data on serial port). In this case, the current consumption of module will be reduced to the minimal level. In SLEEP mode, the module can still receive paging message, voice call and SMS.
GSM	GSM IDLE	Software is active. Module has registered to the GSM network, and the module is ready to communicate.
	GSM TALK	Connection between two subscribers is in progress. In this case, the power consumption depends on network settings (DTX off/on, FR/EFR/HR, hopping sequences, etc.) and antenna.
GPRS	GPRS STANDBY	Module is ready for GPRS data transfer, but no data is currently sent or received. In this case, power consumption depends on network settings and GPRS configuration.
	GPRS DATA	There is GPRS data transfer (PPP or TCP or UDP) in progress. In this case, power consumption is related with network settings (e.g. power control level), uplink/downlink data rates and GPRS configuration (e.g. used multi-slot settings).
EDGE	EDGE STANDBY	Module is ready for data transfer in EDGE mode, but no data is currently sent or received. In this case, power consumption depends on network settings and EDGE configuration.
	EDGE DATA	There is EDGE data transfer (PPP or TCP or UDP) in progress. In this case, power consumption is related with network settings (e.g. power control level), uplink/downlink data rates and EDGE configuration.
WCDMA	WCDMA IDLE	Module has registered to the WCDMA network, and the module is ready to communicate.

	WCDMA TALK	Module is active in WCDMA mode. The power consumption depends on network settings.
HSDPA	HSDPA IDLE	Module is ready for data transmission, but no data is currently sent or received. Power consumption depends on network settings and HSDPA configuration
	HSDPA DATA	There is HSDPA data transfer (PPP or TCP or UDP) in progress. In this case, power consumption is related with network settings (e.g. power control level), uplink/downlink data rates and HSDPA configuration
Power down		Module can be powered down by the AT command “AT+CPOF” or the POWERKEY pin. The power management unit shuts down the power supply of the module, only the power supply of RTC is remained. The serial interface is not accessible. Operating voltage (connected to VBAT) remains applied.
Minimum functionality mode		The AT command “AT+CFUN” can be used to set the module to a minimum functionality mode without removing the power supply. In this mode, the RF part of the module will not work or the SIM card will not be accessible, or both will be closed, and the serial port is still accessible. The power consumption in this mode is very low.

5.2.2 Minimize Power Consumption

There are two modes that SIM5360 achieves low power consumption.

Sleep mode

If peripheral equipments stops working, and there is no on air or hardware interrupts (such as GPIO interrupts or data on UART), SIM5360 will enter sleep mode automatically. In this mode, SIM5360 can still receive paging, voice call or SMS from network. If USB interface of SIM5360 is connected to host CPU, but host CPU does not support USB suspending, then SIM5360 will not enter sleep mode. After USB is disconnected, SIM5360 will enter sleep mode.

Note: When UART interface is connected with host CPU, SIM5360 can not enter sleep mode until RXD is pulled down by the host CPU. If the module is in the idle mode, make sure to pull the RXD to low level by host CPU. SIMCom recommends using GPIO43 or DTR to wake up the module from host CPU and to use GPIO41 or RI to wake up the host CPU. Before designing, pay attention to how to realize waking function and refer to Document[24] and Document[25] for more detail.

Minimum functionality mode

Minimum functionality mode ceases a majority function of module, thus minimizing the power consumption. This mode is set by the AT command which provides a choice of the functionality levels.

- AT+CFUN=0: Minimum functionality
- AT+CFUN=1: Full functionality (Default)
- AT+CFUN=4: Disable RF function of the module (Flight mode)

If SIM5360 has been set to minimum functionality mode, the module will firstly enter sleep mode, then the RF function and SIM card function will be closed. In this case, the serial port is still accessible, but RF

function or SIM card will be unavailable. When SIM5360 is in minimum functionality or flight mode, it can return to full functionality by the AT command “AT+CFUN=1”.

Note: For flight mode, please refer to Chapter3.10.2.

5.3 Current Consumption

The current consumption in suspended mode and without USB connection is listed in the table below. Here, “suspended mode” means that SIM5360 is connected to USB bus, but it does not transfer data.

Table 41: Current consumption

OFF state	
OFF state supply current	Power down 10uA
GSM Sleep mode (without USB connection)	
GSM/GPRS supply current (GNSS off)	Sleep mode @DRX=2 2.7mA
	Sleep mode @DRX=5 1.5mA
	Sleep mode @DRX=9 1.2mA
GSM Sleep Mode (with USB suspended)	
GSM/GPRS supply current (GNSS off)	Sleep mode @DRX=2 3.8mA
	Sleep mode @DRX=5 2.1mA
	Sleep mode @DRX=9 1.7mA
Voice Call	
GSM850	@power level #5 <300mA, Typical 263mA
GSM 900	@power level #5 <300mA, Typical 261mA
DCS1800	@power level #0 <250mA, Typical 218mA
PCS1900	@power level #0 <260mA, Typical 257mA
GPRS Data	
DATA mode, GPRS (1 Rx,4 Tx) CLASS 12	
GSM 850	@power level #5 <660mA, Typical 525mA
GSM 900	@power level #5 <660mA, Typical 480mA
DCS1800	@power level #0 <530mA, Typical 420mA
PCS1900	@power level #0 <530mA, Typical 420mA
DATA mode, GPRS (3Rx, 2 Tx) CLASS 12	
GSM 850	@power level #5 <460mA, Typical 360mA
GSM 900	@power level #5 <440mA, Typical 325mA
DCS1800	@power level #0 <400mA, Typical 285mA
PCS1900	@power level #0 <300mA, Typical 295mA
EDGE Data	
DATA mode, EDGE(1 Rx,4 Tx) CLASS 12	
GSM 850	@power level #8 <500mA, Typical 370mA
GSM 900	@power level #8 <500mA, Typical 365mA
DCS1800	@power level #2 <450mA, Typical 350mA
PCS1900	@power level #2 <450mA, Typical 350mA
DATA mode, EDGE(3Rx, 2 Tx) CLASS 12	

GSM 850	@power level #8 <330mA, Typical 250mA
GSM 900	@power level #8 <330mA, Typical 250mA
DCS1800	@power level #2 <300mA, Typical 225mA
PCS1900	@power level #2 <300mA, Typical 225mA
UMTS Sleep/Idle Mode (without USB connection)	
WCDMA supply current (GNSS off)	Sleep mode@DRX=9 1.1 mA
	Sleep mode @DRX=8 1.3 mA
	Sleep mode @DRX=6 2.8 mA
	Idle mode @DRX=6 15 mA
UMTS Sleep/Idle Mode (with USB suspended)	
WCDMA supply current (GNSS off)	Sleep mode @DRX=9 1.3 mA
	Sleep mode @DRX=8 1.6 mA
	Sleep mode @DRX=6 3.1 mA
	Idle mode @DRX=6 32 mA
UMTS Talk	
WCDMA 2100	@Power 23dBm Typical 460 mA
	@Power 21dBm Typical 410 mA
	@Power 10dBm Typical 245 mA
WCDMA 1900	@Power 23dBm Typical 460 mA
	@Power 21dBm Typical 440 mA
	@Power 10dBm Typical 280 mA
WCDMA 850	@Power 23dBm Typical 440 mA
	@Power 21dBm Typical 400 mA
	@Power 10dBm Typical 250 mA
WCDMA 900	@Power 23dBm Typical 400 mA
	@Power 21dBm Typical 355 mA
	@Power 10dBm Typical 230 mA
HSDPA Data	
WCDMA 2100	@Power 23dBm CQI=22 Typical 520 mA
WCDMA 1900	@Power 23dBm CQI=22 Typical 510 mA
WCDMA 850	@Power 23dBm CQI=22 Typical 460 mA
WCDMA 900	@Power 23dBm CQI=22 Typical 450 mA

5.4 EMC and ESD Notes

EMC tests should be performed to detect any potential problems. Possible harmful emissions radiate by the application to the RF receiver in the receiver band. RF emissions interfere with audio input/output. It is recommended to shield the sensitive components and trace with common ground and user can add beads where necessary.

Normally SIM5360 is mounted on customer host board. Although some ESD components have been added in SIM5360, to prevent ESD, user should put some ESD components on customers' board. The ESD components should be placed beside the connectors which human body might touch, such as SIM card holder, audio jacks, switches, keys, etc. The following table is the SIM5360 ESD measurement performance; the results are from SIMCom EVB test.

Table 42: The ESD performance measurement table (Temperature: 25°C, Humidity: 45%)

Part	Contact discharge	Air discharge
VBAT,GND	±5KV	±10KV
UART,USB	±2KV	±6KV
Antenna port	±5KV	±10KV
Other ports	±2KV	±2KV

6 Guide for Production

6.1 Top and Bottom View of SIM5360



Figure 41: Top and bottom view of SIM5360

These test points are only used for module manufacturing and testing. They are not for customer's application.

6.2 Typical Solder Reflow Profile

For customer convenience, SIMCom provides a typical example for a commonly used soldering profile. In final board assembly, the typical solder reflow profile will be determined by the largest component on the board, as well as the type of solder/flux used and PCB stack-up. Therefore the soldering profile shown below is only a generic recommendation and should be adjusted to the specific application and manufacturing constraints.

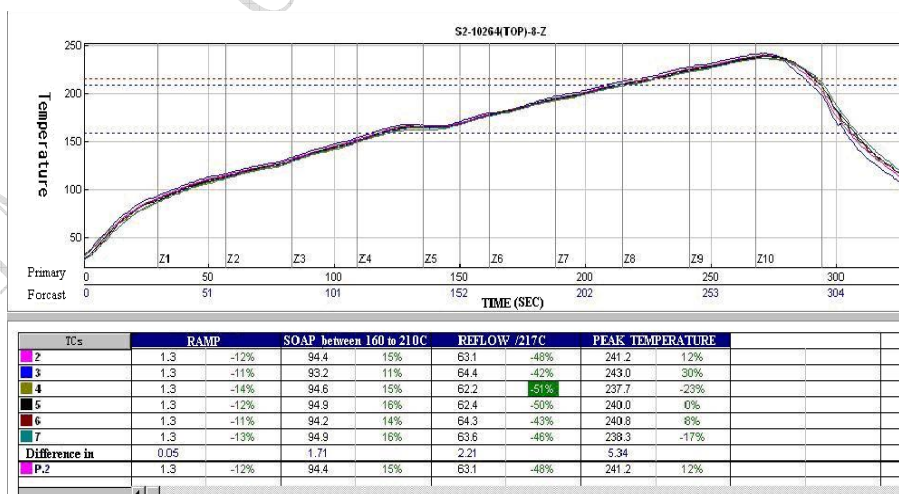

Figure 42: The ramp-soak-spike reflow profile of SIM5360

For details about secondary SMT, please refer to *document [26]*.

6.3 Moisture Sensitivity Level (MSL)

SIM5360 is qualified to Moisture Sensitivity Level (MSL) 5 in accordance with JEDEC J-STD-020. After the prescribed time limit exceeded, users should bake modules for 192 hours in drying equipment (<5% RH) at 40° C +5° C/-0° C, or 72 hours at 85° C +5° C/-5° C. Note that plastic tray is not heat-resistant, users must not use the tray to bake at 85° C or the tray may be damaged.

6.4 Stencil Foil Design Recommendation

The recommended thickness of stencil foil is more than 0.15mm.

SIMCOM CONFIDENTIAL FILE

Appendix

A. Reference Design

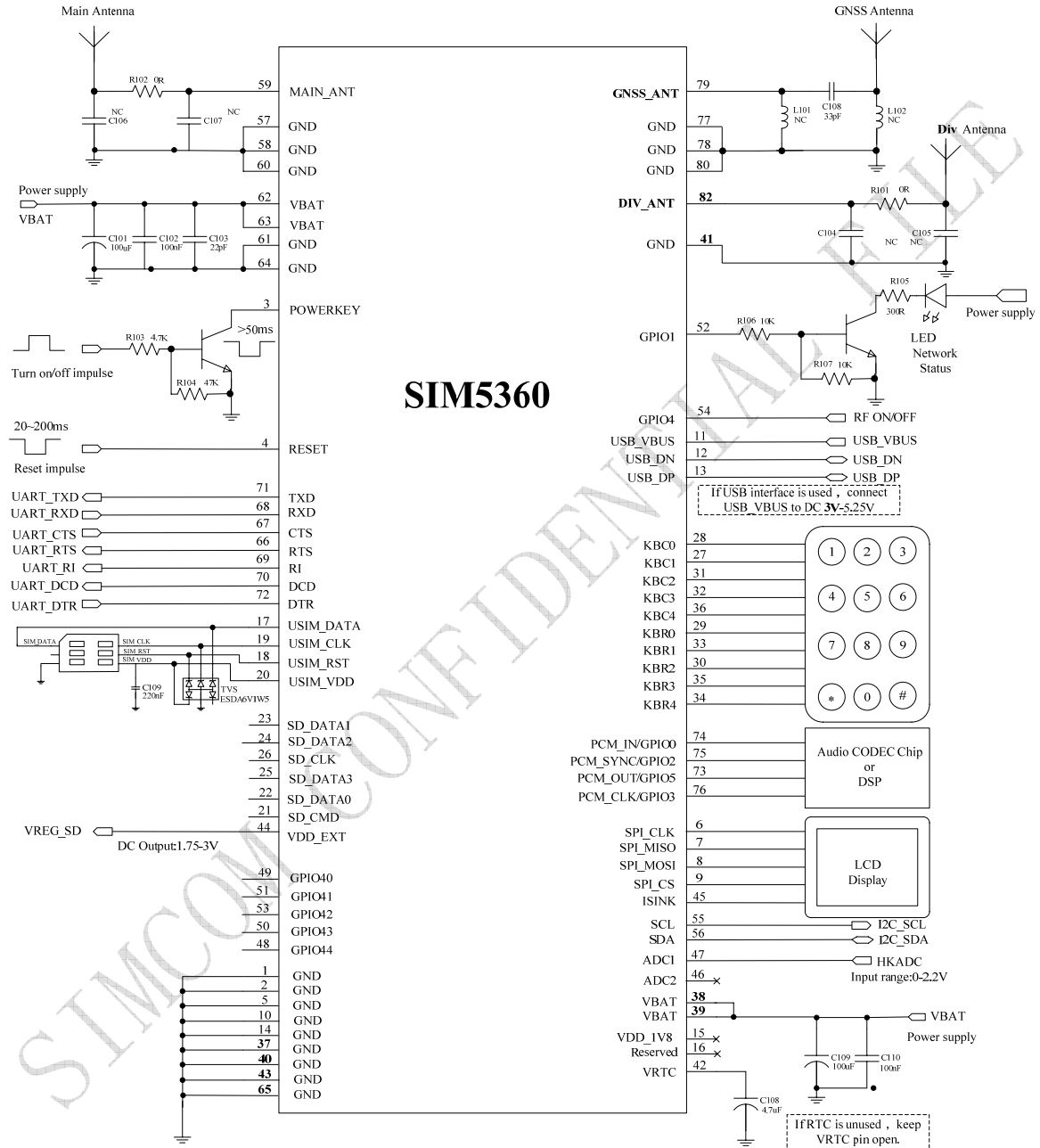

Figure 43: Reference design

B. SIM5360 GPIOs List

Table 43: SIM5360 GPIOs list

Name	GPIO Index	Default Function	Alternate Function
PCM_IN	0	GPIO Interrupt [LEVEL/LOW]	PCM_IN
STATUS_LED	1	Status led	GPIO1
PCM_SYNC	2	GPIO [IN]	PCM_SYNC
PCM_CLK	3	GPIO [OUT/LOW]	PCM_CLK
RF_SWITCH	4	RF Switch	Enable/Disable RF subsystem
PCM_OUT	5	GPIO [OUT/LOW]	PCM_OUT
KBR4	6	Keypad	GPIO
KBR3	7	Keypad	GPIO
KBR2	8	Keypad	GPIO
KBR1	9	Keypad	GPIO
KBR0	10	Keypad	GPIO
KBC4	11	Keypad	GPIO
KBC3	12	Keypad	GPIO
KBC2	13	Keypad	GPIO
KBC1	14	Keypad	GPIO
KBC0	15	Keypad	GPIO
UCTS	33	CTS	GPIO
RTS	34	RTS	GPIO
DTR	35	DTR wake up module	GPIO
DCD	36	DCD	GPIO
RI	37	RI wake up host	GPIO
GPIO40	40	Module power up status	GPIO
GPIO41	41	Wake up host	GPIO
GPIO42	42	GPIO[OUT/LOW]	GPIO
GPIO43	43	Wake up module	GPIO
GPIO44	44	GPIO[OUT/LOW]	GPIO

C. Digital I/O Characteristics

Table 44: Digital I/O characteristics

Parameter	Description	1.8V Digital I/O			Unit
		Min	Typ	Max	
V _{IH}	High-level input voltage	1.26	1.8	2.1	V
V _{IL}	Low-level input voltage	-0.3	0	0.63	V
V _{OH}	High-level output voltage	1.35	1.8	1.8	V

V _{OL}	Low-level output voltage	0	0	0.45	V
IOH	High-level output current	-	1	-	mA
IOL	Low-level output current	-	-1	-	mA
I _{IH}	Input leakage current high	-	-	1	uA
I _{IL}	Input leakage current low	-1	-	-	uA
C _{IN}	Input capacitance	-	-	7	pF

Note: These parameters are for digital interface pins, such as keypad, GPIO, I²C, UART, SPI. Digital I/O specifications under both conditions are presented in the above tables.

D. Related Documents

Table 45: Related documents

SN	Document name	Remark
[1]	SIM5360_ATC_V1.00	SIM5360_ATC_V1.00
[2]	ITU-T Draft new recommendation V.25ter	Serial asynchronous automatic dialing and control
[3]	GSM 07.07	Digital cellular telecommunications (Phase 2+); AT command set for GSM Mobile Equipment (ME)
[4]	GSM 07.10	Support GSM 07.10 multiplexing protocol
[5]	GSM 07.05	Digital cellular telecommunications (Phase 2+); Use of Data Terminal Equipment – Data Circuit terminating Equipment (DTE – DCE) interface for Short Message Service (SMS) and Cell Broadcast Service (CBS)
[6]	GSM 11.14	Digital cellular telecommunications system (Phase 2+); Specification of the SIM Application Toolkit for the Subscriber Identity Module – Mobile Equipment (SIM – ME) interface
[7]	GSM 11.11	Digital cellular telecommunications system (Phase 2+); Specification of the Subscriber Identity Module – Mobile Equipment (SIM – ME) interface
[8]	GSM 03.38	Digital cellular telecommunications system (Phase 2+); Alphabets and language-specific information
[9]	GSM 11.10	Digital cellular telecommunications system (Phase 2); Mobile Station (MS) conformance specification; Part 1: Conformance

		specification
[10]	3GPP TS 51.010-1	Digital cellular telecommunications system (Release 5); Mobile Station (MS) conformance specification
[11]	3GPP TS 34.124	Electromagnetic Compatibility (EMC) for mobile terminals and ancillary equipment.
[12]	3GPP TS 34.121	Electromagnetic Compatibility (EMC) for mobile terminals and ancillary equipment.
[13]	3GPP TS 34.123-1	Technical Specification Group Radio Access Network; Terminal conformance specification; Radio transmission and reception (FDD)
[14]	3GPP TS 34.123-3	User Equipment (UE) conformance specification; Part 3: Abstract Test Suites.
[15]	EN 301 908-02 V2.2.1	Electromagnetic compatibility and Radio spectrum Matters (ERM); Base Stations (BS) and User Equipment (UE) for IMT-2000. Third Generation cellular networks; Part 2: Harmonized EN for IMT-2000, CDMA Direct Spread (UTRA FDD) (UE) covering essential requirements of article 3.2 of the R&TTE Directive
[16]	EN 301 489-24 V1.2.1	Electromagnetic compatibility and Radio Spectrum Matters (ERM); Electromagnetic Compatibility (EMC) standard for radio equipment and services; Part 24: Specific conditions for IMT-2000 CDMA Direct Spread (UTRA) for Mobile and portable (UE) radio and ancillary equipment
[17]	IEC/EN60950-1(2001)	Safety of information technology equipment (2000)
[18]	3GPP TS 51.010-1	Digital cellular telecommunications system (Release 5); Mobile Station (MS) conformance specification
[19]	GCF-CC V3.23.1	Global Certification Forum - Certification Criteria
[20]	2002/95/EC	Directive of the European Parliament and of the Council of 27 January 2003 on the restriction of the use of certain hazardous substances in electrical and electronic equipment (RoHS)
[21]	Audio Application Note V1.01	Audio Application Note V1.01
[22]	Reserved	Reserved
[23]	Keypad Application Note V1.01	Keypad Application Note V1.01
[24]	<i>Sleep_Application_Note</i>	<i>Sleep_Application_Note</i>
[25]	<i>Waking_up_Application_Note</i>	<i>Waking_up_Application_Note</i>
[26]	Module secondary-SMT-UGD	SMT Note
[27]	SIM5xxx_Automatic_POWER_ON_Application_Note	SIM5xxx_Automatic_POWER_ON_Application_Note

E. Terms and Abbreviations







Table 46: Terms and Abbreviations

Abbreviation	Description
ADC	Analog-to-Digital Converter
ARP	Antenna Reference Point
BER	Bit Error Rate
BTS	Base Transceiver Station
CS	Coding Scheme
CSD	Circuit Switched Data
CTS	Clear to Send
DAC	Digital-to-Analog Converter
DRX	Discontinuous Reception
DSP	Digital Signal Processor
DTE	Data Terminal Equipment (typically computer, terminal, printer)
DTR	Data Terminal Ready
DTX	Discontinuous Transmission
EFR	Enhanced Full Rate
EGSM	Enhanced GSM
EMC	Electromagnetic Compatibility
ESD	Electrostatic Discharge
ETS	European Telecommunication Standard
FCC	Federal Communications Commission (U.S.)
FD	SIM fix dialing phonebook
FDMA	Frequency Division Multiple Access
FR	Full Rate
GMSK	Gaussian Minimum Shift Keying
GPRS	General Packet Radio Service
GSM	Global Standard for Mobile Communications
HR	Half Rate
I2C	Inter-Integrated Circuit
IMEI	International Mobile Equipment Identity
Inorm	Normal Current
Imax	Maximum Load Current
kbps	Kilo bits per second
Li-Ion	Lithium-Ion
MO	Mobile Originated
MS	Mobile Station (GSM engine), also referred to as TE
MT	Mobile Terminated
PAP	Password Authentication Protocol
PBCCH	Packet Switched Broadcast Control Channel
PCB	Printed Circuit Board
PCS	Personal Communication System, also referred to as GSM 1900
RF	Radio Frequency
RMS	Root Mean Square (value)
RTC	Real Time Clock

Rx	Receive Direction
SIM	Subscriber Identification Module
SMS	Short Message Service
SPI	serial peripheral interface
TDMA	Time Division Multiple Access
TE	Terminal Equipment, also referred to as DTE
TX	Transmit Direction
UART	Universal Asynchronous Receiver & Transmitter
VSWR	Voltage Standing Wave Ratio
Vmax	Maximum Voltage Value
Vnorm	Normal Voltage Value
Vmin	Minimum Voltage Value
VIHmax	Maximum Input High Level Voltage Value
VIHmin	Minimum Input High Level Voltage Value
VILmax	Maximum Input Low Level Voltage Value
VILmin	Minimum Input Low Level Voltage Value
VImax	Absolute Maximum Input Voltage Value
VImin	Absolute Minimum Input Voltage Value
VOHmax	Maximum Output High Level Voltage Value
VOHmin	Minimum Output High Level Voltage Value
VOLmax	Maximum Output Low Level Voltage Value
VOLmin	Minimum Output Low Level Voltage Value
SM	SIM phonebook
NC	Not connect
EDGE	Enhanced data rates for GSM evolution
HSDPA	High Speed Downlink Packet Access
HSUPA	High Speed Uplink Packet Access
ZIF	Zero intermediate frequency
WCDMA	Wideband Code Division Multiple Access
VCTCXO	Voltage control temperature-compensated crystal oscillator
USIM	Universal subscriber identity module
UMTS	Universal mobile telecommunications system
UART	Universal asynchronous receiver transmitter

F. Safety Caution

Table 47: Safety caution

Marks	Requirements
	When in a hospital or other health care facility, observe the restrictions about the use of mobiles. Switch the cellular terminal or mobile off, medical equipment may be sensitive to not operate normally for RF energy interference.
	Switch off the cellular terminal or mobile before boarding an aircraft. Make sure it is switched off. The operation of wireless appliances in an aircraft is forbidden to prevent interference with communication systems. Forget to think much of these instructions may lead to the flight safety or offend against local legal action, or both.
	Do not operate the cellular terminal or mobile in the presence of flammable gases or fumes. Switch off the cellular terminal when you are near petrol stations, fuel depots, chemical plants or where blasting operations are in progress. Operation of any electrical equipment in potentially explosive atmospheres can constitute a safety hazard.
	Your cellular terminal or mobile receives and transmits radio frequency energy while switched on. RF interference can occur if it is used close to TV sets, radios, computers or other electric equipment.
	Road safety comes first! Do not use a hand-held cellular terminal or mobile when driving a vehicle, unless it is securely mounted in a holder for hands free operation. Before making a call with a hand-held terminal or mobile, park the vehicle.
	<p>GSM cellular terminals or mobiles operate over radio frequency signals and cellular networks and cannot be guaranteed to connect in all conditions, for example no mobile fee or a invalid SIM card. While you are in this condition and need emergent help, please remember using emergency calls. In order to make or receive calls, the cellular terminal or mobile must be switched on and in a service area with adequate cellular signal strength.</p> <p>Some networks do not allow for emergency call if certain network services or phone features are in use (e.g. lock functions, fixed dialing etc.). You may have to deactivate those features before you can make an emergency call.</p> <p>Also, some networks require that a valid SIM card be properly inserted in the cellular terminal or mobile.</p>

Contact us:

Shanghai SIMCom Wireless Solutions Ltd.

Add: SIM Technology Building, No.633, Jinzhong Road, Changning District, Shanghai P.R.
China 200335

Tel: +86 21 3235 3300

Fax: +86 21 3235 3301

URL: www.sim.com/wm

SIMCOM CONFIDENTIAL FILE