

12025 120x120x25MM

General Specifications

- ◆ Material..... Frame: Plastic (UL94V-0)
Impeller: Plastic (UL94V-0)
Lead Wire: UL1007AWG#24 or Equivalent (+) Red, (-) Black
- ◆ Expected Life..... Ball Bearing 70,000hrs (40°C)
Sleeve Bearing 30,000hrs (40°C)
- ◆ Temperature Range... Operating temperature -10°C~70°C (Non-condensing)
Storage temperature -40°C~70°C (Non-condensing)
- ◆ Safety Standards..... UL, TUV, RoHS, CE
- ◆ DC Fan Specials..... RD, FG, PWM, IP56



Specifications

Model	#Bearing Type	Rated Voltage	Operating Voltage	Input Current	Input Power	Speed	Max Air Flow		Max Static Pressure		Noise	Weight
Part No.	B.S	VDC	VDC	Amp	Watt	RPM	CFM	m ³ /min	Inch-H ₂ O	Pa	dB-A	g
DA12025#12U	B.S	12	7.0~13.8	0.80	9.60	3500	122.12	3.46	0.31	77.47	49.0	140.0
DA12025#12H	B.S	12	7.0~13.8	0.50	6.00	3000	103.92	2.94	0.24	60.51	44.0	140.0
DA12025#12M	B.S	12	7.0~13.8	0.40	4.80	2500	86.65	2.45	0.18	44.03	39.0	140.0
DA12025#12L	B.S	12	7.0~13.8	0.20	2.40	2000	67.01	1.90	0.10	26.09	35.0	140.0
DA12025#24U	B.S	24	14.0~27.6	0.50	12.00	3500	122.12	3.46	0.31	77.47	49.0	140.0
DA12025#24H	B.S	24	14.0~27.6	0.40	9.60	3000	103.92	2.94	0.24	60.51	44.0	140.0
DA12025#24M	B.S	24	14.0~27.6	0.25	6.00	2500	86.65	2.45	0.18	44.03	39.0	140.0
DA12025#24L	B.S	24	14.0~27.6	0.15	3.60	2000	67.01	1.90	0.10	26.09	35.0	140.0
DA12025#48U	B.S	48	28.0~56.0	0.40	19.20	3500	122.12	3.46	0.31	77.47	49.0	140.0
DA12025#48H	B.S	48	28.0~56.0	0.30	14.40	3000	103.92	2.94	0.24	60.51	44.0	140.0
DA12025#48M	B.S	48	28.0~56.0	0.20	9.60	2500	86.65	2.45	0.18	44.03	39.0	140.0
DA12025#48L	B.S	48	28.0~56.0	0.10	4.80	2000	67.01	1.90	0.10	26.09	35.0	140.0

Specifications are subject to change without notice. Please visit our website at <http://www.szhxht.com> for update information

Dimensions (Unit:mm)

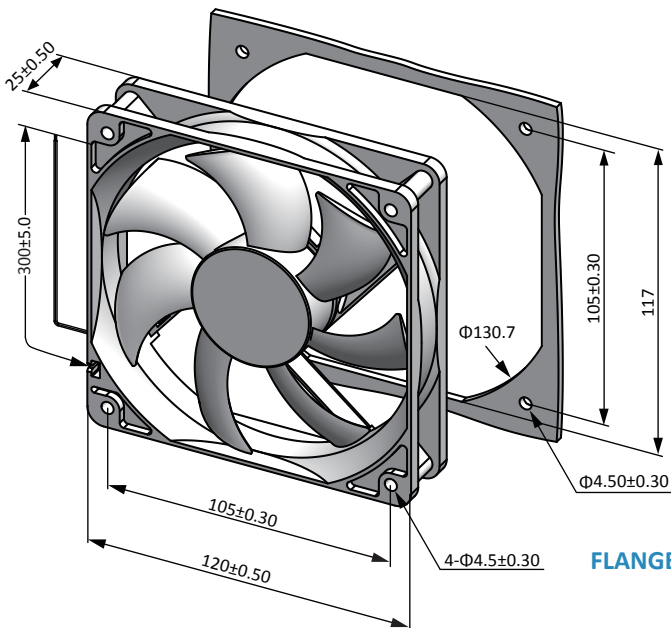

FLANGE AND RIB TYPE

PQ Curve (At rated Voltage)

