

REVISION RECORD

REV	ECN	DESCRIPTION	DRFT	DATE
△	15-0234	弹片使用国产不锈钢,更新料号	WWF	06/19/15

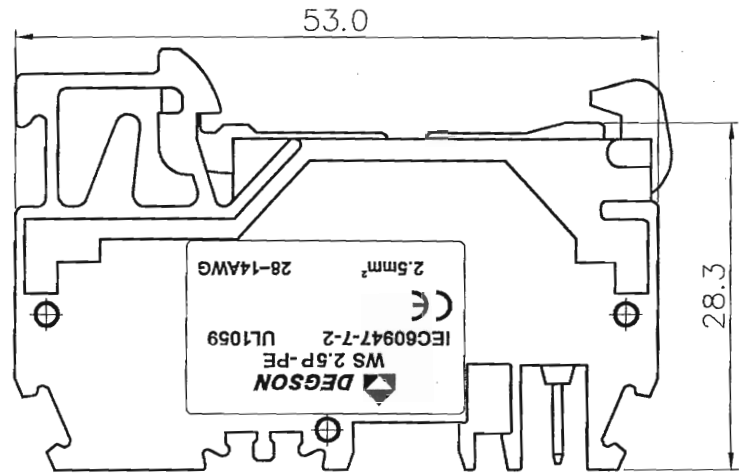

- NOTES:
- 1.DIMENSION SHALL BE INTERPRETED PER ASME Y14.5-2009.
 - 2.PITCH: 5.0MM ,POLES:N=01P
 - 3.OPERATION TEMPERATURES: -40℃~+105℃
 - 4.RATED IMPULSE VOLTAGE: 8KV
 - 5.INSULATION RESISTANCE: 5000MΩ/DC1000V
 - 6.WIRE RANGE: 28~14AWG,0.2~2.5MM²
 - 7.UNDIMENSIONED TOLERANCES:

PITCH RANGE IN MM		NOMINAL DIMENSION RANGE IN MM					-
TO 6	OVER 6 TO 10	OVER 10 TO 24	TO 30	OVER 30 TO 60	OVER 60 TO 100	OVER 100 TO 150	□
±0.10	±0.15	±0.25	±0.20	±0.30	±0.50	±0.70	±1.00/0.05/10

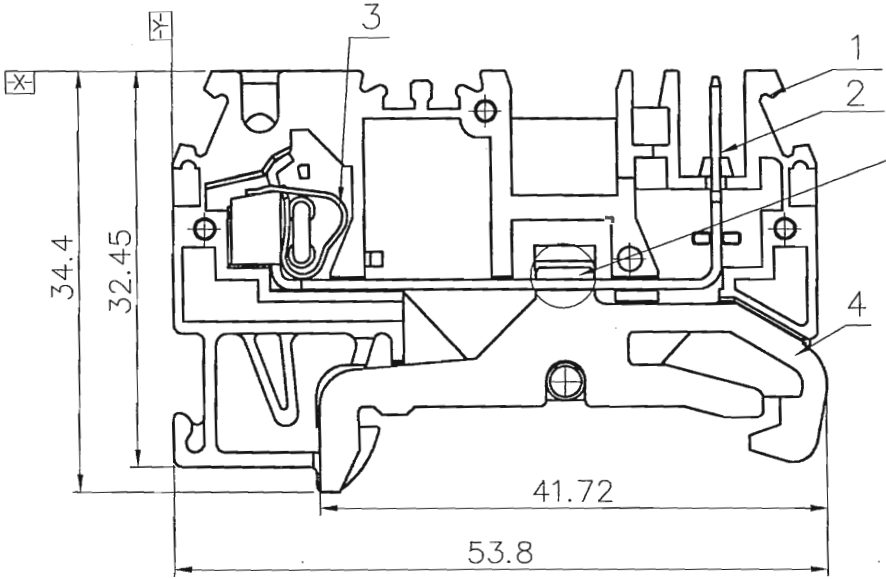
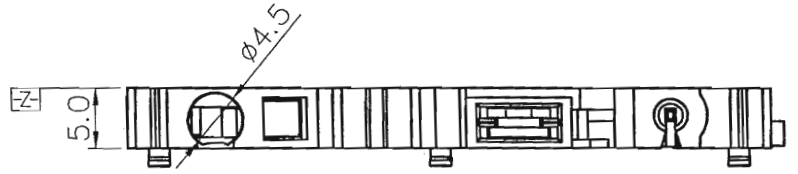

先将载流体与接地体铆接在一起,后在铆接处用锡焊接。
 1.焊接点不能高于载流体平面,
 2.接地体与载流体不能出现松动。

文管中心
 研发专用
 2015.08.11
 (仅限内部使用,对外无效)

ITEM	NAME OF PART	NO. OF PART	Q'TY	MATERIAL	NOTES
4	WS 2.5-PE-GROUND CONTACT	6032B00010(H)	1	PHOSPHOR BRONZE	Sn
3	DG242-5.0-SHRAPNEL	X000006250(H)△	1	STAINLESS STEEL	
2	WS 2.5P-CURRENT CARRIER	6185B00010(H)	1	Copper	Sn
1	WS 2.5P-PE HOUSING	6193A0C01A(H)	1	PA66	UL94V-0

TOLERANCES EXCEPT AS NOTED .X ± .X' ± .XX ± .XX' ± .XXX ± .XXX' ±		MATERIAL: FINISH: PART NO.: NAME:		宁波高正电子有限公司 DEGSON® DEGSON ELECTRONICS CO., LTD	
ANGLES ± 1' THIRD ANGLE PROJECTION		APPD: <i>Avon 6/3/15</i> CHKD: <i>Deary 6/3/15</i> DRFT: Apple 09/02/14		TITLE: ASSEMBLY DRAWING DRAWING NO.: WS 2.5P-PE-E01 DO NOT SCALE DRAWING SCALE N/A SHEET 1/1	