

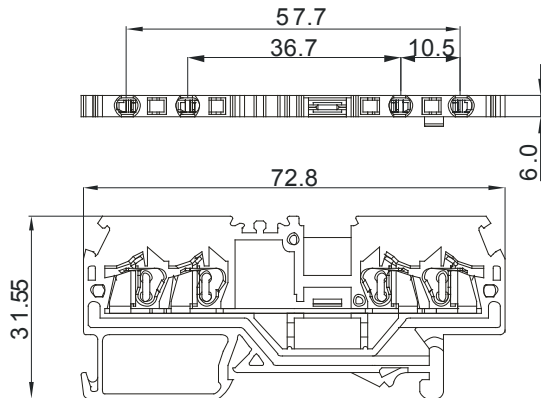

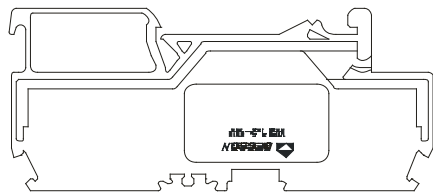

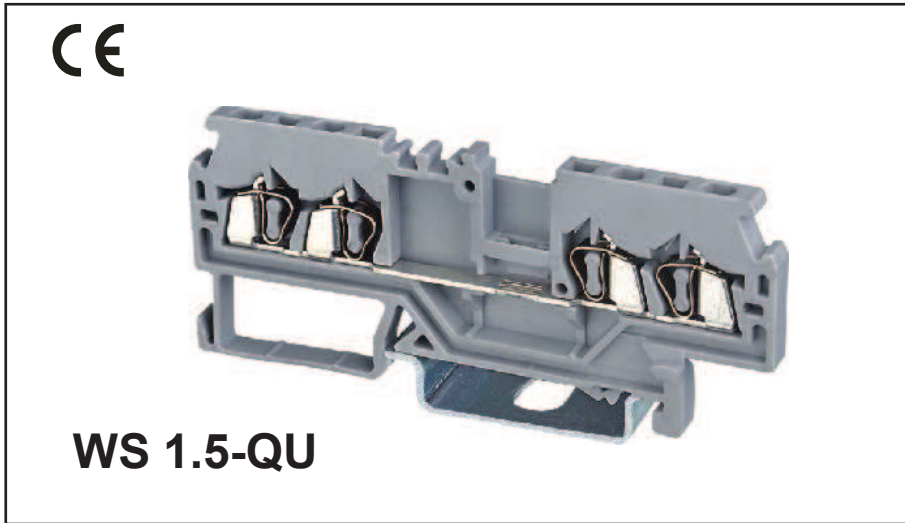







DEGSON ELECTRONICS CO., LTD.

Product Specification



Approval	CE	
Electrical	UL	IEC
Standard	600V	800V
Rated voltage	10A	17.5A
Rated current	28-16AWG	0.2-1.5mm ²
Wire size	4/73/2.5mm	
T/W/End plate	34.5/42mm	
Height(NS35:7.5/NS35:15)	8KV/3	
Rated surge voltage/contamination class	9mm	
Stripping length	PA/V-0	
Insulating material/Inflammability class		

Specification	Model	Pieces
(1) Terminal block	WS 1.5-QU	100
(2) Cover 	D-WS 1.5-QU	100
(3) Adjacent jumper 	WFA-1.5	500
(4) Alternate jumper 	WFB-1.5	350
(5) Staggered jumper 		
	1-2 1-5 1-3 1-6 1-4 1-8	
(6) Insulation stop 	TTA-1.5	200
(7) Protective warning marker 	EEA-1.5	100
(8) Test plug adapter 		
(9) Test plug 		
(9) Zack strip 	DEK4	100

HOW TO ORDER :

 - **P** - 1 -

X	X	X
---	---	---

Series No. No. of pole Color

1	Gray	4	Green	7	Transp-arent
2	Blue	5	Orange	8	Yellow
3	Black	6	Red	9	white

Customer Request

 mm (INCH)	 DEGSON ELECTRONICS CO., LTD.
 THROANGLE PROJECTION	NAME WS 1.5-QU