



健隆投資有限公司  
STRONG BASE INVESTMENT LTD.

Unit 17, 11/F., Hewlett Centre, 52-54 Hoi Yuen Road, Kwun Tong, Kowloon, Hong Kong.  
Tel: (852) 2793 3293 Fax: (852) 2793 3096



Approval Sheet  
(確認書)

編號 Ref. No.	161208-01
日期 Issued Date	2016-12-8

公司名稱 : \_\_\_\_\_  
Company Name

產品編號 : E2-2050AHR2  
Part No.

產品種類 : 数码显示板  
Category

產品描述 : 0.5Inch、高亮红光、双位、共阳、灰面白字  
Description

客戶產品編號 : \_\_\_\_\_  
Customer No.

備注 : \_\_\_\_\_  
Remarks

STRONG BASE			
ISSUER	APPROVER	CHECKER	ENGINEER
	曾雪昭	王金龙	郭清莲

Authorized Signature 客戶簽字				
部門 Department				
簽字 Signature				

工廠名稱: 宇之亮電子(深圳)有限公司  
工廠地址: 廣東省深圳市龍崗區橫崗鎮荷坳村金源工業區  
Company Name: Pretty Light (Shen Zhen) Limited  
Factory Address: jin-Yuan, Industrial Zone He-Ao Cun, Heng-Gang  
Zhen Long-Gang Area, Shen-Zhen City,  
TEL: (755) 8976 7353 FAX: (755) 89767754



健隆投資有限公司

**STRONG BASE INVESTMENT LTD.**

Unit 17, 11/F., Hewlett Centre, 52-54 Hoi Yuen Road, Kwun Tong, Kowloon, Hong Kong.

Tel: (852) 2793 3293 Fax: (852) 2793 3096



**PART No: E2-2050AHR2**

**Client: OZ**

**Single Chip Light Electricity Characteristic Data**

**※Absolute Maximum Ratings at Ta=25°C**

Parameter	Rating	Unit
Power Dissipation Per Chip	50	mW
Perk Forward Current Per Chip (Frequency 10KHz,1/10Duty Cycle)	60	mA
Reverse Voltage Per Chip	5	V
Operating Temperature Range	-20~+80	°C
Storage Temperature Range	-20~+85	°C
Storage Humidity	45%~85%	

**※Electrical and Optical Characteristics at Ta=25°C**

Parameter	Symbol	Condition	Color	Min	Typ	Max	Unit
Forward Voltage Per Chip	VF	IF=20mA	Red	1.7	2.0	2.5	v
Reverse Current	IR	VR=5V	-	-	-	50	uA
Luminous Intensity Per Chip	IV	IF=20mA	Red	7	10	14	mcd
Dominant Wave Length	$\lambda d$	IF=20mA	Red	638	645	650	nm
Normal Forward Current	IF		All Color	5	10	20	mA

Note : Soldering Bath : not more than 4 seconds @260°C ◦ The bottom ends of plastic reflector should be at least 2mm above the solder surface ◦

Soldering Iron : not more than 3 seconds @300°C under 30W ◦



PART No.: E2-2050AHR2

Client: OZ

PACKAGE DIMENSION (Unit: mm Tolerance: ±0.5)

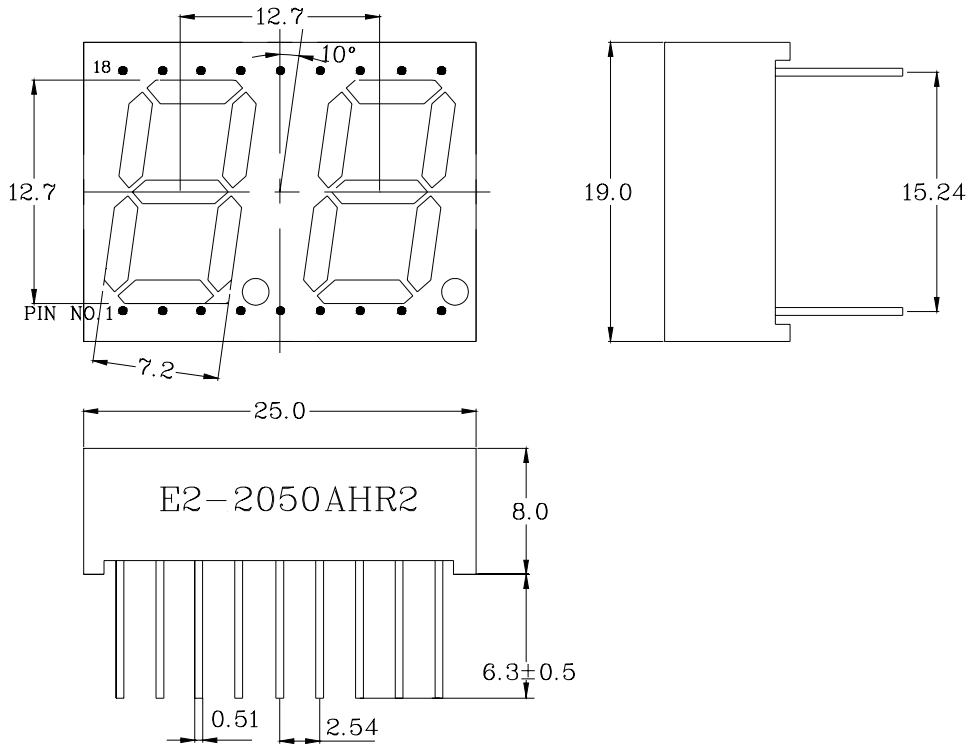

INTERNAL CIRCUIT DIAGRAM

Pin Function

