

## Specification of Li-ion Rechargeable Battery

### 锂离子电池规格书

Model: 303258PL520/3.7V

拟制 Prepared by	审批 Checked by	核准 Approved by
杨应荣	罗亮	

客户确认 Customer Confirmation	客户名称 Customer Name:
	客户审核 Customer Approval:

Wuhan Forte Battery Co.,Ltd  
Wujiashan Taiwan Businessmen Investment Zone, Wuhan, Hubei, China  
Tel: 86-027-8325 8996 Fax:86-027-8325 9120  
<http://www.whforte.com>

修订记录

AMENDMENT RECORDS

修订 REVISION	时间 DATE	制定 ORIGINATOR	翻修原因 REASON FOR REVISION

### Content 目录

1. Scope 范围 .....	3
2. Reference Standard 参考标准 .....	3
3. Basic of performance 基本性能 .....	3
4. Electrical Characteristics 电性能 .....	4
4.1 Normal Test Conditions 标准测试条件 .....	4
4.2 Electrochemical Characteristics 电化学性能 .....	4
4.3 Environment Characteristics 环境适应性能 .....	5
4.4 Safety Characteristics 安全性能 .....	6
5. Storage and Shipment Requirement 存储及运输要求 .....	7
6. Protection Circuit 保护电路 .....	8
7. Warning and Cautions 警告及注意事项 .....	9
8. NOTE 声明 .....	11

#### 1. Scope 范围

This specification describes the performance, testing method, warning and caution of the lithium-ion rechargeable battery.

The specification applies to polymer battery supplied by Wuhan Forte Battery Co.,Ltd

锂离子电 池规格书  
Specification of Li-ion Rechargeable Battery

**2303258PL520mAh-3.7V**

编 号：K20161208-1

版 本：A01

页 码：3/100

本标准描述了锂离子电池的性能、测试方法及注意事项。

## 2. Reference Standard 参考标准

The standard refer to GB/T18287-2000, UL1642 and the other technology standard.

本标准参考国标 GB/T18287-2000、UL1642 等技术标准规范编制而成。

## 3. Basic of performance 基本性能

No.	Item 项目	Specification 性能
1	Rated Capacity 额定容量	520mAh ,0.2 C discharging
2	Minimum Capacity 最小容量	520mAh ,0.2 C discharging
3	Normal Voltage 标称电压	3.7V
4	O.C.V 出厂电压	3.7-4.2
5	Charge Ending Voltage 充电截止电压	4.2±0.02V
6	放电截止电压 Discharge Ending Voltage	2.75V±0.02V
7	Standard charging method 标准充电方式	0℃ ~ 45℃ 0.5C constant charge to 4.2V, then constant voltage 4.2V charge till charged current declines to ≤ 0.01C 0℃~45℃0.5C 恒流充电至 4.2V, 然后恒压 4.2V 充电直到充电电流下降到≤0.01C
8	Standard Charge current 充电电流	0.2C
9	charging Time 充电时间	Standard charge:5.5 ~ 6.5 h 标准充电: 5.5 ~ 6.5 h
		Rapid charge:1.5 ~ 2.5 h 快速充电: 1.5 ~ 2.5 h
10	Max. Charging Current 最大充电电流	1.0C
11	Standard discharging Current 标准放电电流	0.2C
12	Max. Discharging Current 最大放电电流	1.0C
13	Operating environment 工作环境	充电 Charging: 0℃-45℃, 65%±25%RH 放电 Discharging: -20℃-80℃, 65%±25%RH

**锂离子电池规格书**  
Specification of Li-ion Rechargeable Battery

编号：K20161208-1

版本：A01

页码：4/100

**2303258PL520mAh-3.7V**

14	Cell Impedance 单电芯内阻	< 180 mΩ, (4.2V AC 1KHz measured)	
15	Dimension of Single Cell 单电芯尺寸	Thickness	3mm±0.3mm
		Width	32mm±0.5mm
		Height	58mm±0.5mm

**PACK 尺寸**

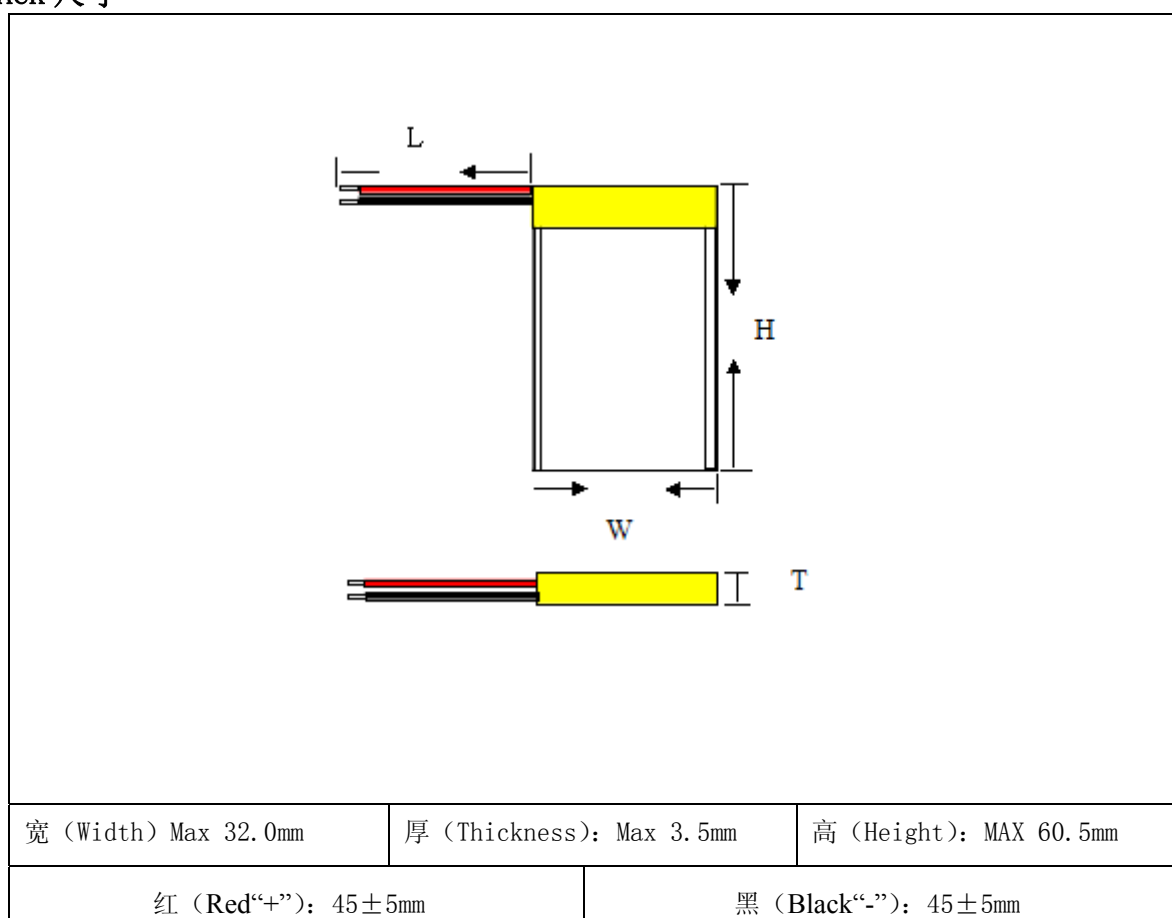

**4. Electrical Characteristics 电性能**

**4.1 Normal Test Conditions 标准测试条件**

Temperature: 15~35 °C

Relative Humidity: 45-85%RH

Atmospheric pressure: 86 -106 KPa

除非另有规定，本规格书中的各项测试应在标准大气条件下进行：

温度：15~35 °C

相对湿度：45-85%RH

大气压力：86 ~106 KPa

**锂离子电池规格书**  
Specification of Li-ion Rechargeable Battery

编号：K20161208-1  
版本：A01  
页码：5/100

**2303258PL520mAh-3.7V**

**4.2 Electrochemical Characteristics 电化学性能**

NO. 序号	Item 项目	Criterion 性能标准	Test Method 测试方法
1	0.2C discharging capacity 0.2C 放电 性能	Discharging capacity is not less than normal capacity. 放电容量应不 小于标称容量	After Standard Charging, rest 5 minutes ,then 0.2C discharge to ending voltage 标准充电后, 电芯放置 5 分钟, 再 0.2C 放电至 终止电压。
2	1C discharging capacity 1C 放电性 能	Discharging capacity is not less than 90% normal capacity. 放电容量应不 小于标称容量 的 90%	After Standard Charging, rest 5 minutes ,then 1C discharge to ending voltage 标准充电后, 电芯放置 5 分钟, 再 1C 放电至 终止电压。
3	Cycle life 循环寿命	The cycle times is not less than 300 循环次数不小 于 300 次	Test condition : Charge : 0.5C to 4.2V Discharge : 0.5C to 3.0V When the discharge capacity reduced to 80% of rated capacity, Stop testing 测试条件 : 充电 : 0.5C 充电到 4.2V 放电 : 0.5C 放电到 3.0V 当放电容量降至额定容量的 80% 时, 停止测试。
4	Self- discharge 自放电	Discharging capacity is not less than 90% initial capacity 放电容量应不 低于初始容量 的 90%	After Standard Charging, test condition : Temperature : 20±5 °C Storage Time : 28days Then 0.2C discharge to ending voltage 标准充电后, 测试条件如下 : 温度 : 20±5 °C 搁置时间 : 28 天 再以 0.2C 放电至终止电压。

**4.3 Environment Characteristics 环境适应性能**

NO 序号	Item 项目	Criterion 性能标准	Test Method 测试方法
1	Constant temperature and constant humidity	No explosion, no fire, no leakage. Discharging capacity is not less than 85%	After Standard Charging, test condition : Temperature : 40±5 °C Relative Humidity : 90~95%RH Storage Time : 96 hours Then return to room temperature for 2 hours,

**锂离子电池规格书**  
Specification of Li-ion Rechargeable Battery

编号：K20161208-1  
版本：A01  
页码：6/100

**2303258PL520mAh-3.7V**

	test 恒定湿热	initial capacity 不起火、不爆炸、不泄漏。 放电容量不低于初始容量的85%	Then 1C discharged to ending voltage 标准充电后，测试条件如下： 温度：40±5℃ 相对湿度：90~95% 放置时间：96 小时 电芯取出在室温下放置 2 小时，然后以 1C 电流放电至终止电压。
2	Vibration test 振动	No explosion, no fire, no leakage 不起火、不爆炸、不泄漏。	After Standard Charging, fixed the cell to vibration table, then subjected to vibration test for 30 minutes per axis of XYZ axes Frequency rate : 1oct/min Vibration frequency : 10Hz-55Hz Excursion (single amplitude) : 0.8mm 电芯按标准充电后，固定在振动台上，然后沿XYZ 每个坐标方向振动 30 分钟 扫频速率：1oct/min 振动频率：10Hz~55Hz 位移幅值(单振幅)：0.8mm
3	Shock test 碰撞	No explosion, no fire, no leakage 不起火、不爆炸，不泄漏。	After Standard Charging, test condition : Acceleration : 100m/s <sup>2</sup> Pulse lasting time : <16ms Shock times : 1000±10 times 标准充电后，测试条件如下： 加速度：100m/s <sup>2</sup> 脉冲持续时间：<16ms 碰撞次数：1000±10

**4.4 Safety Characteristics 安全性能**

NO 序号	Item 项目	Criterion 性能指标	Test Method 测试方法
1	Overcharge test 过充电性能	No explosion, no fire 不起火、不爆炸	Discharge : 1C to3.0V Charge : 1C charge to 4.8V, and maintain 8 h 放电：1C 放电至 3.0V 充电：1C 充电 4.8V，保持 8 小时
2	Short circuit test 短路	No explosion, no fire, The temperature of the surface of the Cells are lower than 150℃ 不起火、不爆炸,电芯表面	After Standard Charging, Short circuit the positive and negative, and the resistance of copper wire is not more than 100mΩ。 标准充电后，使用总内阻不大于 100mΩ 的导线短路正负极。

**锂离子电池规格书**  
Specification of Li-ion Rechargeable Battery

**2303258PL520mAh-3.7V**

编 号：K20161208-1

版 本：A01

页 码：7/100

		温 度 不 超 过 150℃。	
3	Forced discharge 过放试验	No explosion, no fire 不起火、不爆 炸	Discharge at a current of 1 C for 2.5h. 以 1C 的电流放电 2.5 小时
4	Free fall test 自由跌落	No Leakage ,no explosion, no fire 。 不漏液，不爆 炸，不起火。	The battery to be fully charged with standard charging condition ,then fall from height of 1.0m and hit onto concrete ground 2 times 电池标准充电后，让其从 1.0m 高处自由落下，跌 落在混凝土地面上 2 次。

Note: Above testing of safe characteristics must be with protective equipment.

备注：以上安全性能实验应在有保护措施的条件下进行。

### 5. Storage and Shipment Requirement 存储及运输要求

Item 项目	Requirement 要求
Short period less than 1 month 短期少于一个月	-20℃ ~ +45℃, 65%±25%RH
Long period less than half year 长期小于半年	-20℃ ~ + 35℃, 65%±25%RH
Long period less than 1 year 长期小于一年	0℃~+30℃, 65%±25%RH
Long time storage : If the cell is stored for a long time, the cell's storage voltage should be 3.70-3.95V and the cell is to be stored in a condition as above requirement. Also, it is recommended to charge the cell every six months.	

### 6. Protection Circuit 保护电路

#### 6.1 Schematic of the pcb 保护板原理图

**锂离子电池规格书**  
Specification of Li-ion Rechargeable Battery

**2303258PL520mAh-3.7V**

编号：K20161208-1  
版本：A01  
页码：8/100

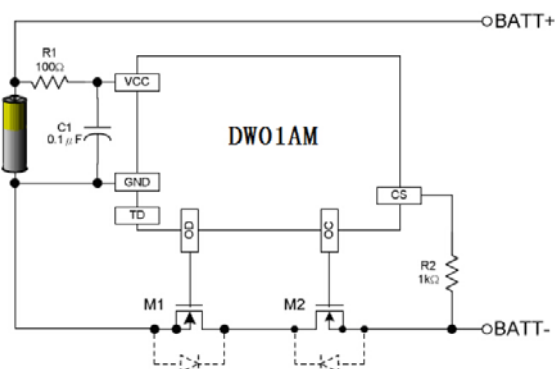

6.2 PCB BOM PCB 物料表

No.	Material code	Material name	Specifications Model	Unit	Qty	Remarks	Manufacturers
1	U1	Protection IC	DW01AM SOT-23-6	个	1		
2	U2	Power Mosfet	8205 TSSOP-6	个	1		
3	R1	Resistor	101 5% 1/16W 0603	个	1		
4	R2	Resistor	102 5% 1/16W 0603	个	1		
5	C1	Capaction	104 5% 25V 0603	个	1		
6	PCB		3.8*27*0.6	个	1		

6.3 PCB Parameter PCB 参数

No.	测试内容 Test content	检测标准值 Detection of standard value	判定条件 Determination conditions
1	过充保护电压 Overcharge protection voltage	4.3±0.05V	TA=25°C
2	过放保护电压 Discharge protection voltage	2.4V±0.1V	
3	过流保护电压 Overcurrent protection voltage	150mV±30mV	
4	充电保护延迟时间 Charging protection delay time	80ms	
5	放电保护延迟时间 Discharge protection delay time	40ms	



**锂离子电池规格书**  
Specification of Li-ion Rechargeable Battery

**2303258PL520mAh-3.7V**

编 号：K20161208-1  
版 本：A01  
页 码：9/100

6	过放电流保护延迟时间 Discharge current protection delay time	10ms	TA=25℃
7	过充电流保护延迟时间 Overcharge current protection delay time	5ms	TA=25℃
8	PCB 内阻 PCB resistance	《50mΩ	TA=25℃
9	自耗电电流 Since current consumption	1ua	

**7. Warning and Cautions 警告及注意事项**

Danger warning (it should be described in manual or instruction for users, indicated especially) to prevent the possibility of the battery from leaking, heating, explosion. Please observe the following precautions:

危险警告：(应在使用说明手册或说明书中，特别注明) 为防止电池可能发生泄漏，发热，爆炸，请注意以下预防措施：

Don't immerse the battery in water and seawater. Please put it in cool and dry environment if no using.

严禁将电池浸入海水或水中，保存不用时，应放置在阴凉干燥的环境中。

Do not discard or leave the battery near a heat source as fire or heater

禁止将电池在热高温源（如火、加热器）旁等使用、留置或丢入。

Being charged, using the battery charger specifically for that purpose

充电时请选用锂离子电池专用充电器。

Don't reverse the positive and negative terminals

严禁颠倒正负极使用电池。

Don't connect the battery to an electrical outlet directly.

严禁将电池直接接入电源插座。

Don't connect the positive and negative terminal directly with metal objects such as wire. Short terminals of battery is strictly prohibited, it may damage battery.

禁止用金属直接连接电池正负极短路，任何时候禁止短路电芯，它会导致电芯严重损坏。

Do not transport and store the battery together with metal objects such as necklaces, hairpins.

禁止将电池与金属，如发夹，项链等一起运输或贮存。

Do not strike, throw or trample the battery.

禁止敲击或抛掷，踩踏电池等。

Do not directly solder the battery and pierce the battery with a nail or other sharp object

禁止直接焊接电池和用钉子或其它利器刺穿电池。

Do not use lithium ion battery and others different lithium polymer battery model in mixture

禁止与液态锂离子或不同型号的聚合物锂电池混合使用

Prohibition of use of damaged cells

禁止使用已损坏的电芯

Don't bend or fold sealing edge. Don't open or deform folding edge Don't fillet the end of the folding edge

禁止弯折顶封边，禁止打开或破坏折边，禁止导折电芯折边底部

Don't fall, hit, bend battery body.

禁止坠落、冲击、弯折电池。

Battery pack designing and packing Prohibition injury batteries.

**锂离子电池规格书**  
Specification of Li-ion Rechargeable Battery

**2303258PL520mAh-3.7V**

编 号：K20161208-1

版 本：A01

页 码：10/100

电池外壳设计和包装禁止损伤电池。

Never disassemble the cells

在任何情况下不得拆卸电 池

The battery replacement shall be done only by either cells supplier or device supplier and never be done by the user.

更换电芯应由电 池供应商或设备供应商完成，用户不得自行更换。

Keep the battery away from babies.

电 池应远离小孩。

Caution 小心

◆ Do not use or leave the battery at very high temperature conditions (for example, strong direct sunlight or a vehicle in extremely hot conditions). Otherwise, it can overheat or fire or its performance will be degenerate and its service life will be decreased.

禁止在高温下（直热的阳光下或很热的汽车中）使用或放置电 池，否则可能会引起电 池过热，起火或功能失效，寿命减短。

◆ Do not use it in a location where is electrostatic and magnetic greatly, otherwise, the safety devices may be damaged, causing hidden trouble of safety.

禁止在强静电和强磁场的地方使用，否则易破坏电 池安全保护装置，带来不安全的隐患。

◆ If the battery leaks, and the electrolyte get into the eyes. Do not wipe eyes, instead, rinse the eyes with clean running water, and immediately seek medical attention. Otherwise, eyes injury can result.

如果电 池发生泄漏，电解液进入眼睛，请不要揉擦，应用清水冲洗眼睛，并立即送医治疗，否则会伤害眼睛。

◆ If the battery gives off an odor, generates heat, becomes discolored or deformed, or in any way appear abnormal during use, recharging or storage, immediately remove it from the device or battery charge and stop using it.

如果电 池发出异味，发热，变色，变形或使用，贮存，充电过程中出现任何异常现象，立即将电 池从装置或充电器中移离并停用。

◆ In case the battery terminals are dirt, clean the terminals with a dry cloth before use. Otherwise power failure or charge failure may occur due to the poor connection with the instrument.

如果电 池弄脏，使用前应用干布抹净，否则可能会导致接触不良功能失效。

Prohibition of use of damaged cells

禁止使用已损坏的电芯

◆ Be aware discharged batteries may cause fire; tape the terminals to insulate them.

废弃之电 池应用绝缘纸包住电极，以防起火，爆炸。

## 8. Note 声明

Note (1): The customer is requested to contact in advance if and when the variations of the operating conditions described in this document. Additional experimentation may be required to verify performance and safety under such conditions.

声明一：

客户若需要将电 池用于超出文件以外的设备，或在文件规定以外的使用条件下使用电 池，应事先联系。因为需要进行特定的实验测试以核实电芯在该使用条件下的性能及安全性。

Note (2): take no responsibility for any accident when the cell is used under conditions outside of this specification.

声明二：

对于在超出文件规定以外的条件下使用电芯而造成的任何意外事故，概不负责。

锂离子电池规格书  
Specification of Li-ion Rechargeable Battery

**2303258PL520mAh-3.7V**

编号：K20161208-1

版本：A01

页码：11/100

Note (3): inform the customer in writing of improvement(s) regarding proper use and handling of the cell if it is deemed necessary.

Energy reserves the right to revise this specification before the customer signs the datasheet. If a revision is required, notify the customer.

声明三：

如有必要会以书面形式告知客户有关正确操作使用电芯的改进措施。

在规格书未签确前，本公司有权对本产品规格书进行修订，如有必要修订后将会通知客户