

WHITE LED STEP-UP CONVERTER

FEATURES

- Inherently Matched LED Current
- Drives Up to 8 LEDs from a 3.6V Supply
- No External Schottky Diode Required
- 1.2MHz Switching Frequency

- Automatic Soft-Start
- Open LED Protection
- High Efficiency: 81%

- Requires Only 0.22mF Output Capacitor
- Low Profile (1mm) SOT-23 Packaging

APPLICATION

- Cellular Phones
- PDAs, Handheld Computers
- Digital Cameras
- MP3 Players
- GPS Receivers

DESCRIPTION

The YT2665 IS step-up DC/DC converters designed to drive up to six LEDs in series from a Li-Ion cell. Series connection of the LEDs provides identical LED currents and eliminates the need for ballast resistors. These devices integrate the Schottky diode required externally on competing devices. Additional features include output voltage limiting when LEDs are disconnected, one-pin shutdown and dimming control. The YT2665 has internal soft-start.

The YT2665 switches at 1.2MHz, allowing the use of tiny external components. Constant frequency switching results in low input noise and a small output capacitor. Just 0.22 μ F is required for 4-, 6- or 8-LED applications. The YT2665 is available in low profile(1mm)6-lead

TYPICAL APPLICATION

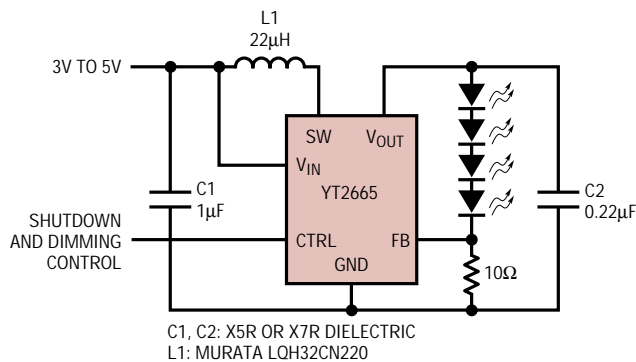
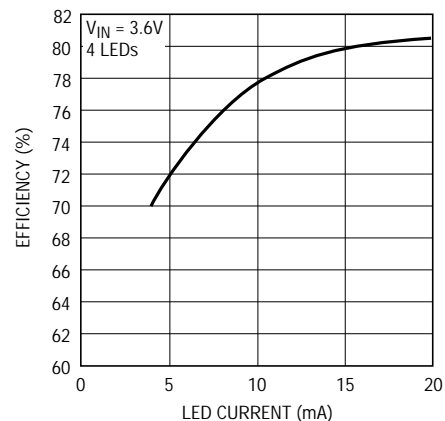

Figure 1. Li-Ion Powered Driver for Four White LEDs

Conversion Efficiency



ABSOLUTE MAXIMUM RATINGS
(Note 1)

Input Voltage (V_{IN})	16V
SW Voltage	36V
FB Voltage	2V
CTRL Voltage	10V
Operating Temperature Range (Note 2) ..	-40°C to 85°C
Maximum Junction Temperature	125°C
Storage Temperature Range	-65°C to 150°C
Lead Temperature (Soldering, 10 sec)	300°C

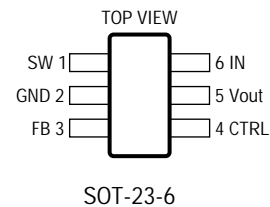
PACKAGE/ORDER INFORMATION

ELECTRICAL CHARACTERISTICS

The ● denotes the specifications which apply over the full operating temperature range, otherwise specifications are at $T_A = 25^\circ\text{C}$. $V_{IN} = 3\text{V}$, $V_{CTRL} = 3\text{V}$, unless otherwise noted.

PARAMETER	CONDITIONS		MIN	TYP	MAX	UNITS
Minimum Operating Voltage			2.7			V
Maximum Operating Voltage					1	V
Feedback Voltage	$0^\circ\text{C} \leq T_A \leq 85^\circ\text{C}$		188	200	212	mV
FB Pin Bias Current			10	35	100	nA
Supply Current	Not Switching $CTRL = 0\text{V}$		1.9 2.0	2.6 3.2	3.3 5.0	mA uA
Switching Frequency			0.8	1.2	1.6	MHz
Maximum Duty Cycle		●	90	93		%
Switch Current Limit		●	225	340		mA
Switch V_{CESAT}	$I_{SW} = 250\text{mA}$			30		mV
Switch Leakage Current	$V_{SW} = 5\text{V}$			0.01	5	uA
V_{CTRL} for Full LED Current			1.8			V
V_{CTRL} to Shut Down Chip					50	mV
CTRL Pin Bias Current	$T_A = 85^\circ\text{C}$ $T_A = -40^\circ\text{C}$		48 40 60	60 50 75	70 60 90	uA uA uA
Soft-Start Time				600		μs
Schottky Forward Drop	$I_D = 150\text{mA}$			0.7		V
Schottky Leakage Current	$V_R = 30\text{V}$				4	uA

Note 1: Absolute Maximum Ratings are those values beyond which the life of a device may be impaired.

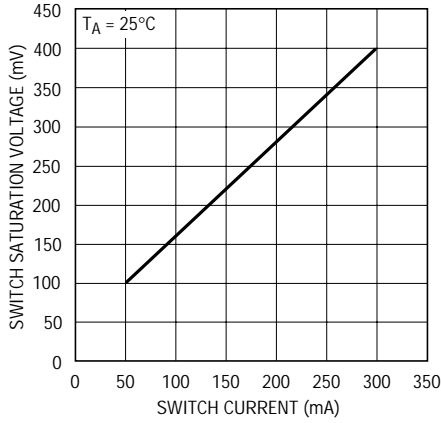
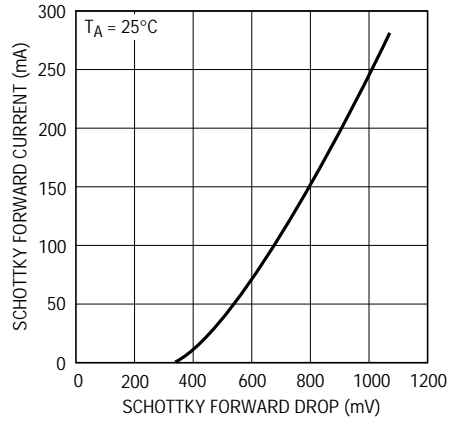
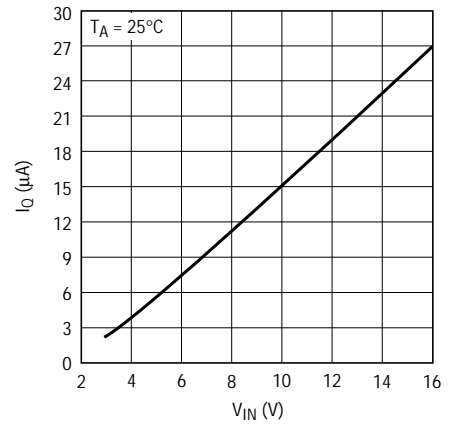
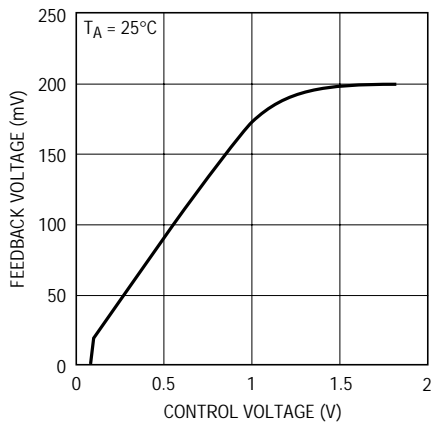
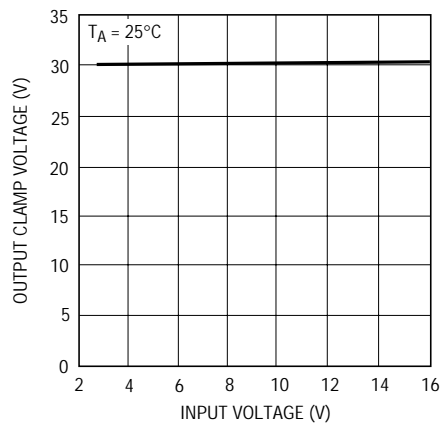
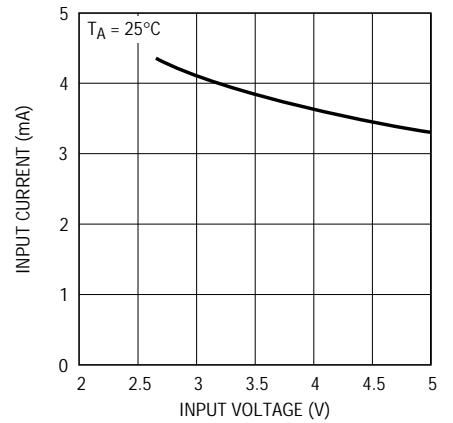
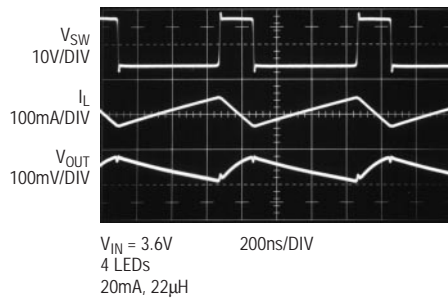
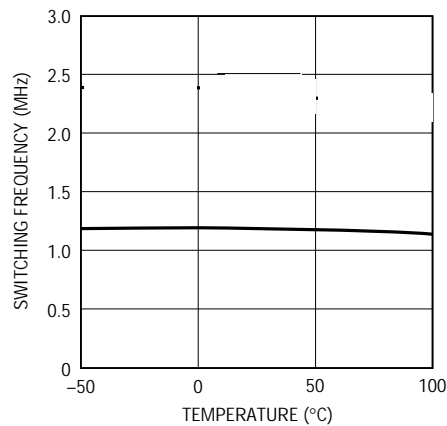
Note 2: The YT2665 are guaranteed to meet performance specifications from 0°C to 70°C. Specifications over the -40°C to 85°C operating temperature range are assured by design, characterization and correlation with statistical process controls.

TYPICAL PERFORMANCE CHARACTERISTICS
Switch Saturation Voltage (V_{CESAT})

Schottky Forward Voltage Drop

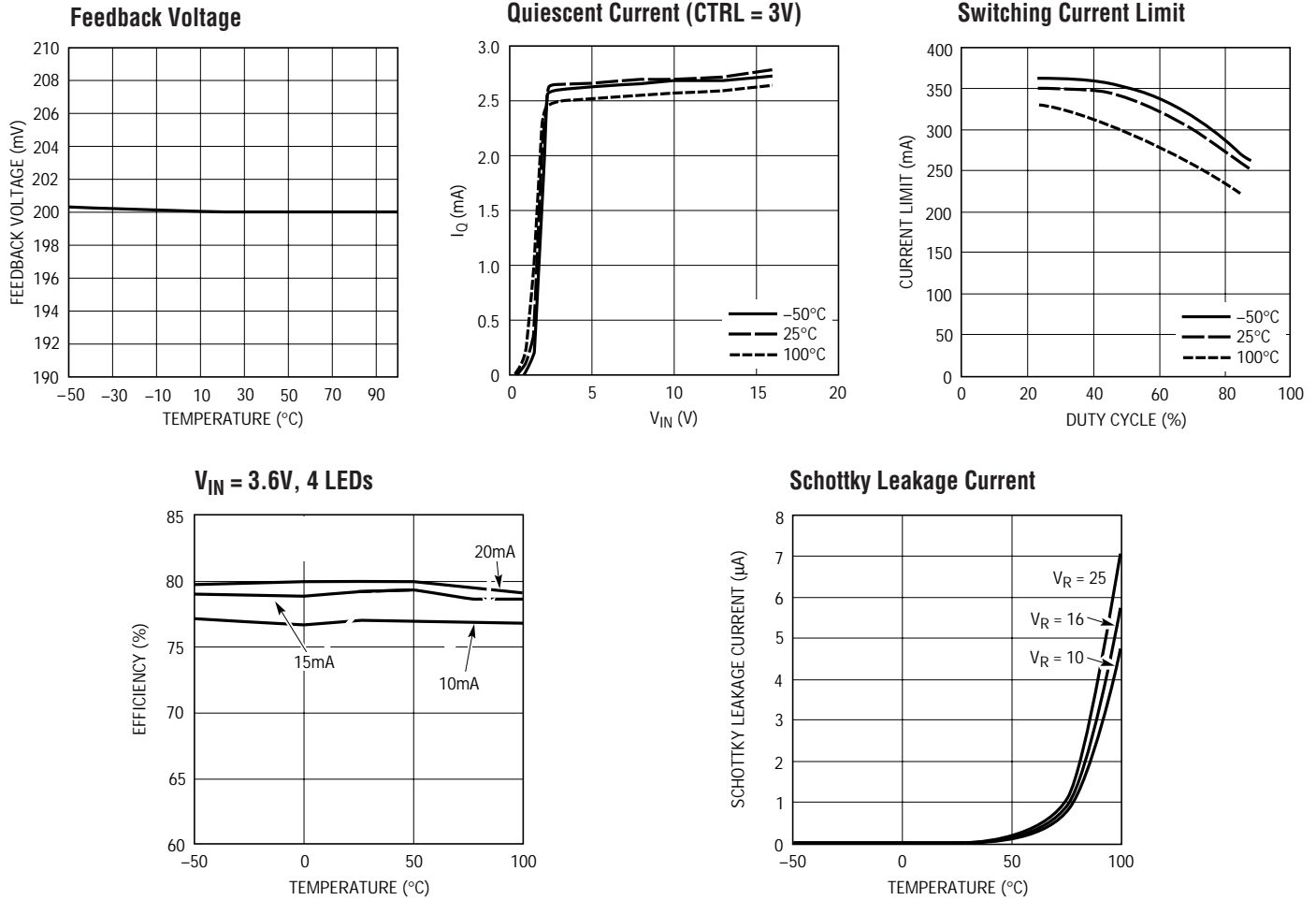
Shutdown Quiescent Current (I_Q) ($CTRL = 0V$)

 V_{FB} vs V_{CTRL}

Open-Circuit Output Clamp Voltage

Input Current in Output Open Circuit

Switching Waveforms

Switching Frequency

TYPICAL PERFORMANCE CHARACTERISTICS



PIN FUNCTIONS

V_{OUT} (Pin 1): Output Pin. Connect to output capacitor and LEDs. Minimize trace between this pin and output capacitor to reduce EMI.

GND (Pin 2): Ground Pin. Connect directly to local ground plane.

FB (Pin 3): Feedback Pin. Reference voltage is 200mV. Connect LEDs and a resistor at this pin. LED current is determined by the resistance and CTRL pin voltage:

$$I_{LED} \approx \frac{200\text{mV}}{R_{FB}} \text{ When } V_{CTRL} > 1.8\text{V}$$

$$I_{LED} \approx \frac{V_{CTRL}}{5 \cdot R_{FB}} \text{ When } V_{CTRL} < 1\text{V}$$

CTRL (Pin 4): Dimming Control and Shutdown Pin. Ground this pin to shut down the device. When V_{CTRL} is greater than about 1.8V, full-scale LED current is generated. When V_{CTRL} is less than 1V, LED current is reduced.

V_{IN} (Pin 5): Input Supply Pin. Must be locally bypassed with a 1µF X5R or X7R type ceramic capacitor.

SW (Pin 6): Switch Pin. Connect inductor here.

BLOCK DIAGRAM

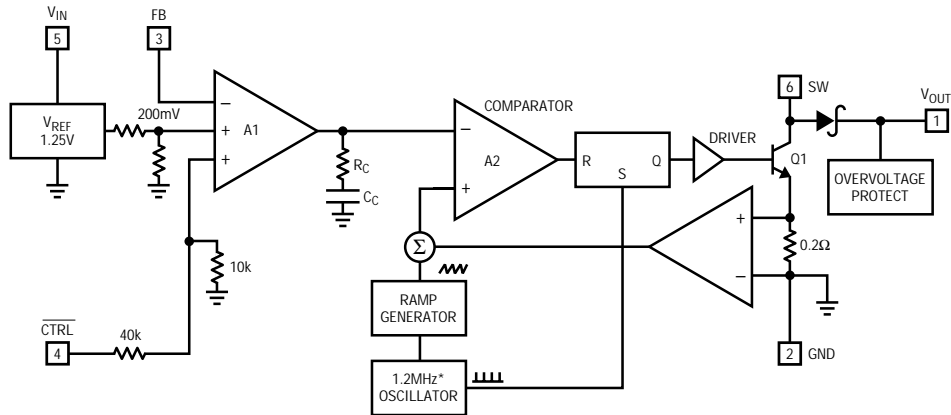

Figure 2. YT2665 Block Diagram

APPLICATIONS INFORMATION

Operation

The YT2665 uses a constant frequency, current mode control scheme to provide excellent line and load regulation. Operation can be best understood by referring to the block diagram in Figure 2. At the start of each oscillator cycle, the SR latch is set, which turns on the power switch Q1. A voltage proportional to the switch current is added to a stabilizing ramp and the resulting sum is fed into the positive terminal of the PWM comparator A2. When this voltage exceeds the level at the negative input of A2, the SR latch is reset turning off the power switch. The level at the negative input of A2 is set by the error amplifier A1, and is simply an amplified version of the difference between the feedback voltage and the reference voltage of 200mV. In this manner, the error amplifier sets the correct peak current level to keep the output in regulation. If the error amplifier's output increases, more current is delivered to the output; if it decreases, less current is delivered. The CTRL pin voltage is used to adjust the reference voltage.

result in some low frequency ripple, although the LED current remains regulated on an average basis down to zero. The photo in Figure 3a details circuit operation driving three white LEDs at a 1.5mA load. Peak inductor current is less than 40mA and the regulator operates in discontinuous mode, meaning the inductor current

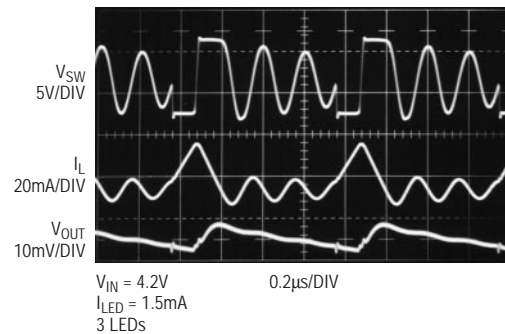

Figure 3. Switching Waveforms

Minimum Output Current

The YT2665 can drive a 3-LED string at 1.5mA LED current without pulse skipping. As current is further reduced, the device will begin skipping pulses. This will

APPLICATIONS INFORMATION

reaches zero during the discharge phase. After the inductor current reaches zero, the SW pin exhibits ringing due to the LC tank circuit formed by the inductor in combination with switch and diode capacitance. This ringing is not harmful; far less spectral energy is contained in the ringing than in the switch transitions. The ringing can be damped by application of a 300Ω resistor across the inductor, although this will degrade efficiency. Because of the higher switching frequency, The photo in Figure 3b details circuit operation driving three white LEDs at a 0.2mA load. Peak inductor current is less than 30mA.

Inductor Selection

A 22μH inductor is recommended for most YT2665 applications. Although small size and high efficiency are major concerns, the inductor should have low core losses at 1.2MHz and low DCR (copper wire resistance). Some inductors in this category with small size are listed in Table 1. The efficiency comparison of different inductors is shown in Figure 4a.

Table 1. Recommended Inductors

PART NUMBER	DCR (Ω)	CURRENT RATING (mA)	MANUFACTURER
LQH32CN220	0.71	250	Murata
LQH2MCN220	2.4	185	814-237-1431 www.murata.com
ELJPC220KF	4.0	160	Panasonic 714-373-7334 www.panasonic.com
CDRH3D16-220	0.53	350	Sumida 847-956-0666 www.sumida.com
LB2012B220M	1.7	75	Taiyo Yuden 408-573-4150 www.t-yuden.com
LEM2520-220	5.5	125	Taiyo Yuden 408-573-4150 www.t-yuden.com

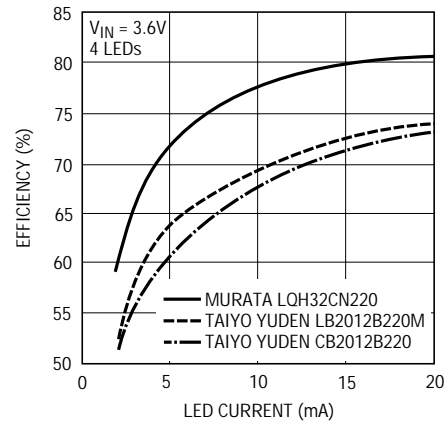

Figure 4. Efficiency Comparison of Different Inductors

Capacitor Selection

The small size of ceramic capacitors makes them ideal for YT2665 applications. X5R and X7R types are recommended because they retain their capacitance over wider voltage and temperature ranges than other types such as Y5V or Z5U. A 1μF input capacitor and a 0.22μF output capacitor are sufficient for most YT2665 applications.

Table 2. Recommended Ceramic Capacitor Manufacturers

MANUFACTURER	PHONE	URL
Taiyo Yuden	408-573-4150	www.t-yuden.com
Murata	814-237-1431	www.murata.com
Kemet	408-986-0424	www.kemet.com

APPLICATIONS INFORMATION

Soft-Start

The YT2665 has an internal soft-start circuit to limit the input current during circuit start-up. The circuit start-up waveforms are shown in Figure 5.

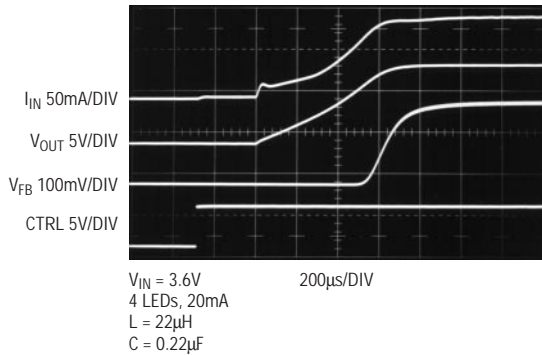

Figure 5. Start-Up Waveforms

Inrush Current

The YT2665 have a built-in Schottky diode. When supply voltage is applied to the V_{IN} pin, the voltage difference between V_{IN} and V_{OUT} generates inrush current flowing from input through the inductor and the Schottky diode to charge the output capacitor to V_{IN} . The maximum current the Schottky diode in the YT2665 can sustain is 1A. The selection of inductor and capacitor value should ensure the peak of the inrush current to be below 1A. The peak inrush current can be calculated as follows:

$$I_P = \frac{V_{IN} - 0.6}{L \cdot \omega} \cdot \exp\left[-\frac{\alpha}{\omega} \cdot \arctan\left(\frac{\omega}{\alpha}\right)\right] \cdot \sin\left[\arctan\left(\frac{\omega}{\alpha}\right)\right]$$

$$\alpha = \frac{r + 1.5}{2 \cdot L}$$

$$\omega = \sqrt{\frac{1}{L \cdot C} - \frac{(r + 1.5)^2}{4 \cdot L^2}}$$

where L is the inductance, r is the resistance of the inductor and C is the output capacitance. For low DCR inductors, which is usually the case for this application, the peak inrush current can be simplified as follows:

$$I_P = \frac{V_{IN} - 0.6}{L \cdot \omega} \cdot \exp\left(-\frac{\alpha}{\omega} \cdot \frac{\pi}{2}\right)$$

Table 3 gives inrush peak currents for some component selections.

Table 3. Inrush Peak Current

V_{IN} (V)	r (Ω)	L (μH)	C (μF)	I_P (A)
5	0.5	22	0.22	0.38
5	0.5	22	1	0.70
3.6	0.5	22	0.22	0.26
5	0.5	33	1	0.60

LED Current and Dimming Control

The LED current is controlled by the feedback resistor (R_1 in Figure 1) and the feedback reference voltage.

$$I_{LED} = V_{FB}/R_{FB}$$

The CTRL pin controls the feedback reference voltage as shown in the Typical Performance Characteristics. For CTRL higher than 1.8V, the feedback reference is 200mV, which results in full LED current. CTRL pin can be used as dimming control when CTRL voltage is between 200mV to 1.5V. In order to have accurate LED current, precision resistors are preferred (1% is recommended). The formula and table for R_{FB} selection are shown below.

$$R_{FB} = 200mV/I_{LED-Full} \quad (1)$$

Table 4. R_{FB} Resistor Value Selection

FULL I_{LED} (mA)	R_1 (Ω)
5	40.0
10	20.0
15	13.3
20	10.0

The filtered PWM signal can be considered as an adjustable DC voltage. It can be used to adjust the CTRL voltage source in dimming control. The circuit is shown in Figure 6. The corner frequency of $R_1 C_1$ should be lower than the frequency of the PWM signal. R_1 needs to be much smaller than the internal impedance in the CTRL pin, which is 50k Ω .

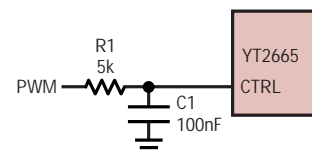

Figure 6. Dimming Control Using a Filtered PWM Signal

APPLICATIONS INFORMATION

Dimming Using Direct PWM

Unlike the YT2665 does not have internal soft-start. Although the input current is higher during start-up, the absence of soft-start allows the CTRL pin to be directly driven with a PWM signal for dimming. A zero percent duty cycle sets the LED current to zero, while 100% duty cycle sets it to full current. Average LED current increases proportionally with the duty cycle of the PWM signal. PWM frequency should be between 1kHz and 10kHz for best performance. The PWM signal should be at least 1.8V in magnitude; lower voltage will lower the feedback voltage as shown in Equation 1. Waveforms are shown for a 1kHz PWM and 10kHz PWM signal in Figures 7a and 7b respectively.

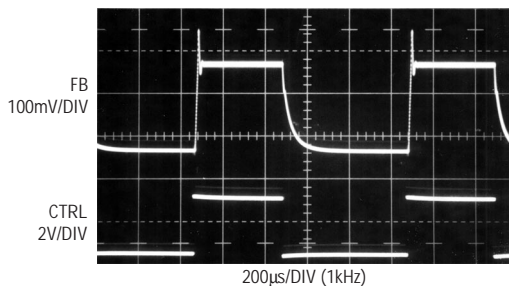

Figure 7a.

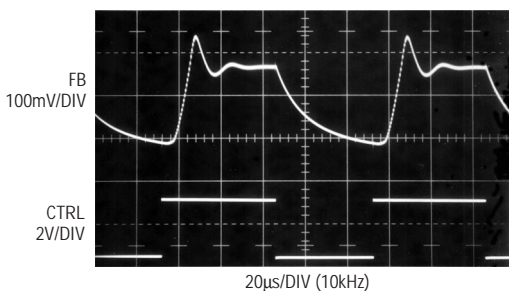

Figure 7b.

Open-Circuit Protection

The YT2665 have an internal open-circuit protection circuit. In the cases of output open circuit, when the LEDs are disconnected from the circuit or the LEDs fail, the VOUT is clamped at 30V. The YT2665 will then switch at a very low frequency to

minimize the input current. V_{OUT} and input current during output open circuit are shown in the Typical Performance Characteristics.

Board Layout Consideration

As with all switching regulators, careful attention must be paid to the PCB board layout and component placement. To maximize efficiency, switch rise and fall times are made as short as possible. To prevent electromagnetic interference (EMI) problems, proper layout of the high frequency switching path is essential. Place C_{OUT} next to the V_{OUT} pin. Always use a ground plane under the switching regulator to minimize interplane coupling. In addition, the ground connection for the feedback resistor R₁ should be tied directly to the GND pin and not shared with any other component, ensuring a clean, noise-free connection. Recommended component placement is shown in Figure 8.

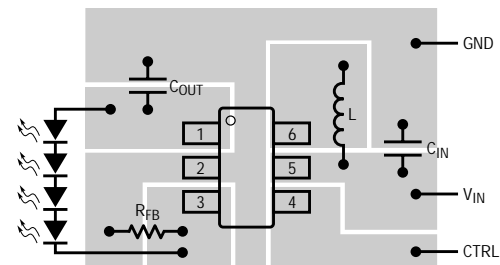
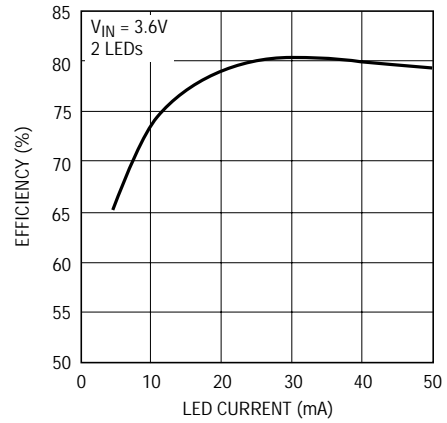
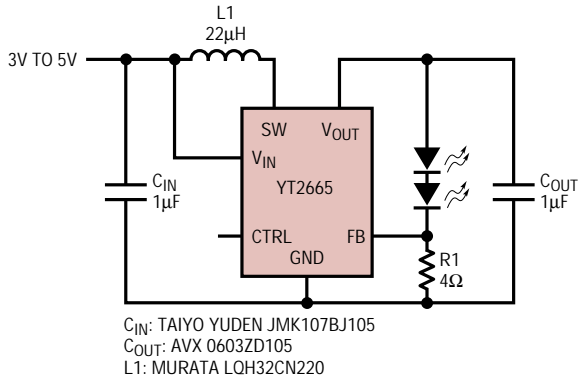
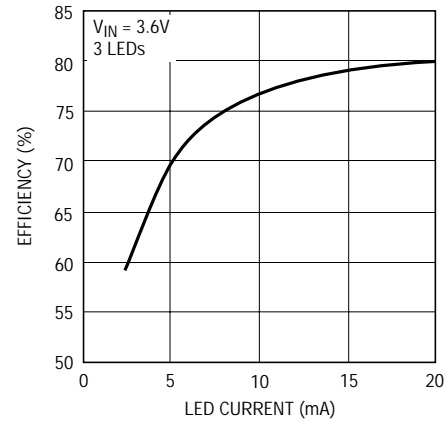
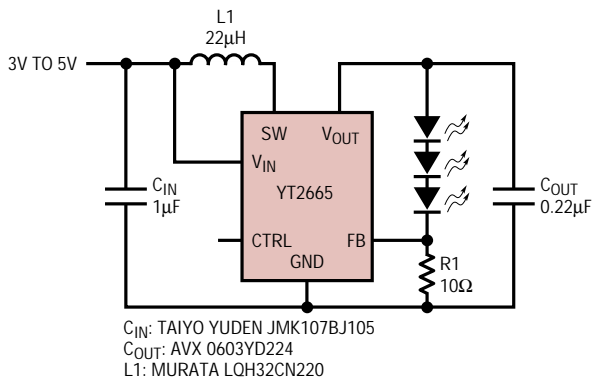
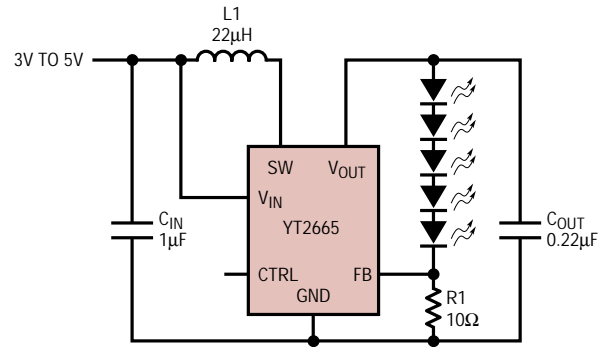
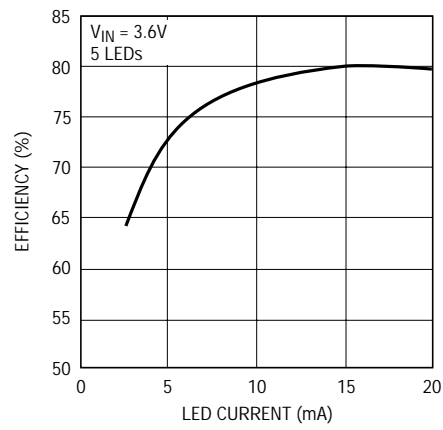

Figure 8. Recommended Component Placement

TYPICAL APPLICATIONS
Li-Ion to Two White LEDs

Li-Ion to Three White LEDs

TYPICAL APPLICATIONS
Li-Ion to Five White LEDs

C_{IN} : TAIYO YUDEN JMK107BJ105
 C_{OUT} : TAIYO YUDEN GMK212BJ224
 $L1$: MURATA LQH32CN220



PACKAGE DESCRIPTION

S6 Package
6-Lead Plastic SOT-23
 (Reference LTC DWG # 05-08-1636)

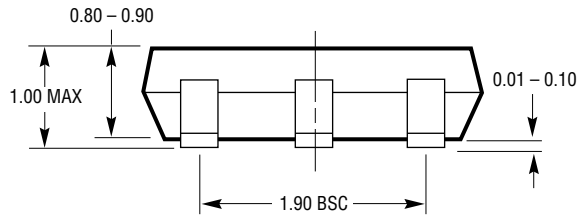
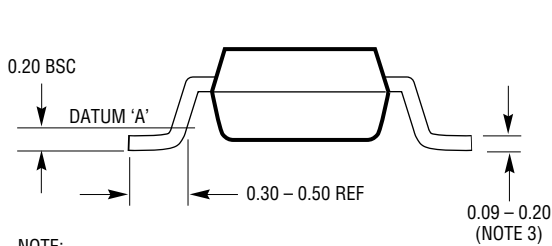
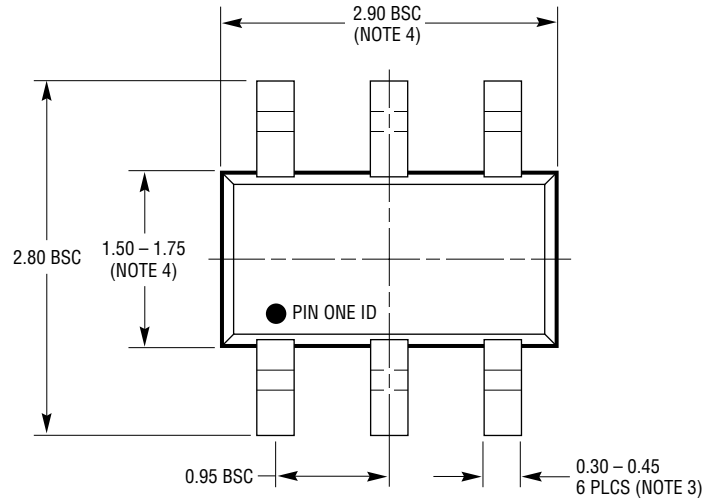
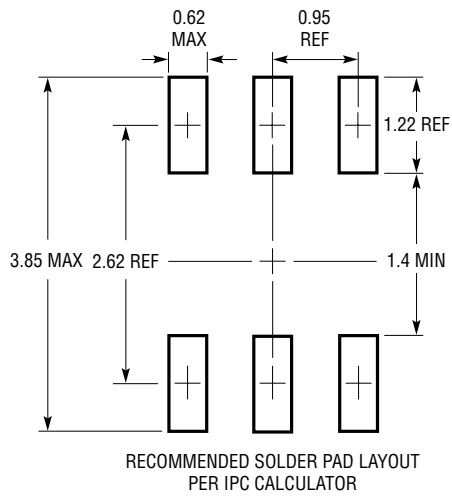

- NOTE:
1. DIMENSIONS ARE IN MILLIMETERS
 2. DRAWING NOT TO SCALE
 3. DIMENSIONS ARE INCLUSIVE OF PLATING
 4. DIMENSIONS ARE EXCLUSIVE OF MOLD FLASH AND METAL BURR
 5. MOLD FLASH SHALL NOT EXCEED 0.254mm
 6. JEDEC PACKAGE REFERENCE IS MO-193

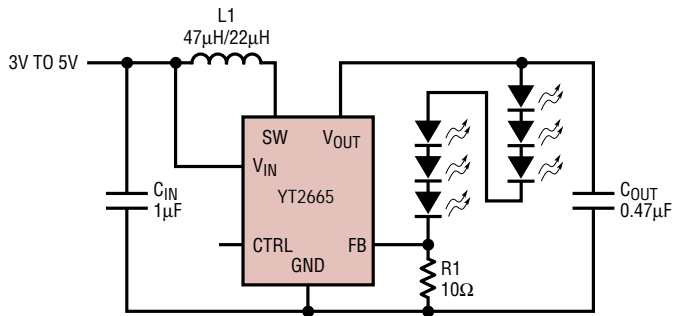
TYPICAL APPLICATIONS
Li-Ion to Six White LEDs

C_{IN} : TAIYO YUDEN JMK107BJ105
 C_{OUT} : TAIYO YUDEN GMK212BJ474
 $L1$: MURATA LQH32CN470

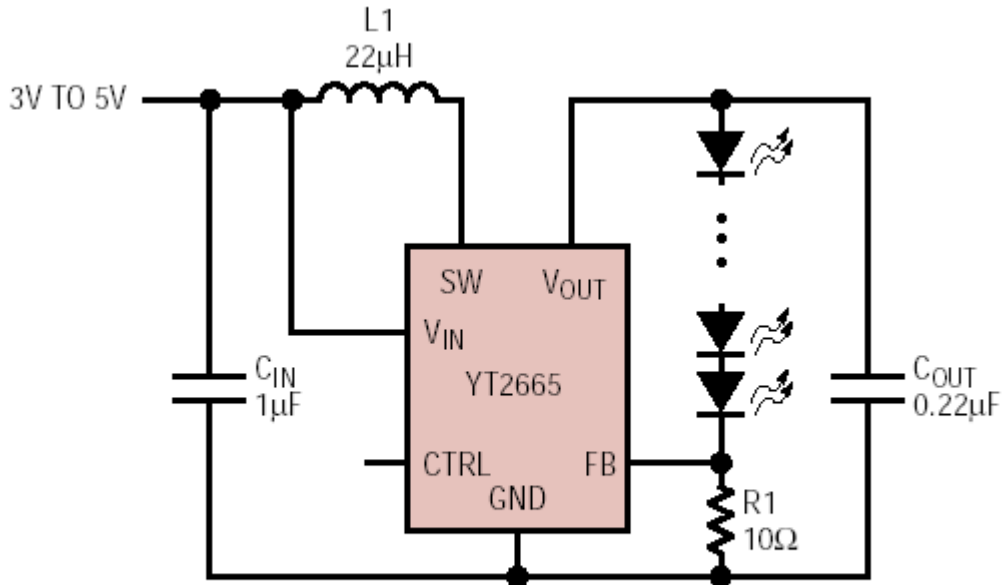
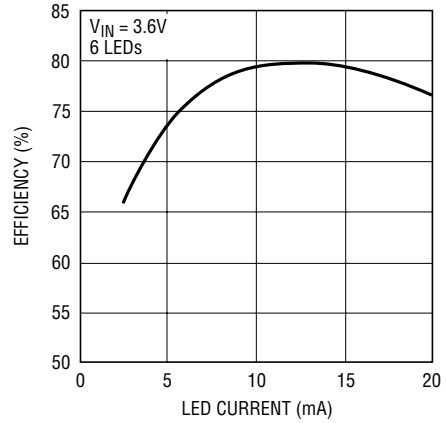

C_{IN} : TAIYO YUDEN JMK107BJ105
 C_{OUT} : TAIYO YUDEN GMK212BJ224
 $L1$: MURATA LQH32CN220