

**1MHz 1A Step-Down DC/DC Converter**

**General Description**

The AAT1150 is a step-down, SwitchReg™, switching converter ideal for applications where high efficiency, small size, and low ripple are critical. Able to deliver 1A with internal power MOSFETs, the current-mode controlled IC provides high efficiency using synchronous rectification. Fully internally compensated, the AAT1150 simplifies system design and lowers external parts count.

The AAT1150 is available in a Pb-free, MSOP-8 package and is rated over the -40°C to +85°C temperature range.

**Features**

- $V_{IN}$  Range: 2.7V to 5.5V
- Up to 95% Efficiency
- 110mΩ  $R_{DS(ON)}$  MOSFET Switch
- <1.0µA of Shutdown Current
- 1MHz Switching Frequency
- Adjustable  $V_{OUT}$ : 1.0V to 4.2V
- High Initial Accuracy: ±1%
- 1.0A Peak Current
- Integrated Power Switches
- Synchronous Rectification
- Internally Compensated Current Mode Control
- Constant PWM Mode for Low Output Ripple
- Internal Soft Start
- Current Limit Protection
- Over-Temperature Protection
- MSOP-8 package
- -40°C to +85°C Temperature Range

**Applications**

- Cable/DSL Modems
- Computer Peripherals
- High Efficiency Conversion From 5V or 3.3V Supply
- Network Cards
- Set-Top Boxes

**Typical Application**

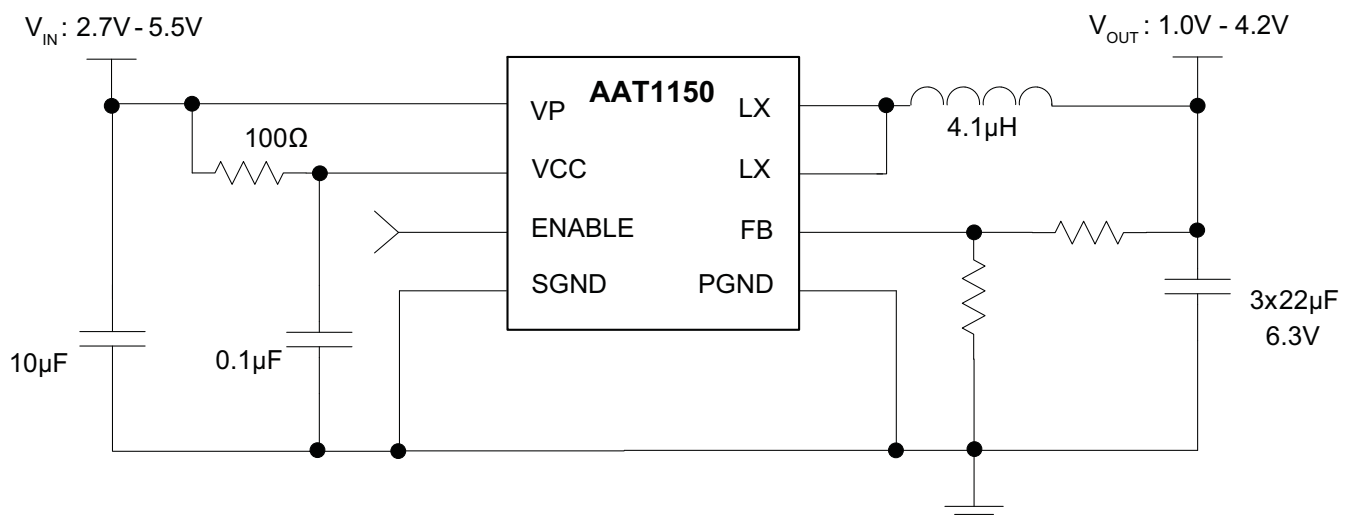

# AAT1150

## 1MHz 1A Step-Down DC/DC Converter

### Pin Descriptions

Pin #	Symbol	Function
1	FB	Feedback input pin. This pin is connected to an external resistive divider for an adjustable output.
2	SGND	Signal ground.
3	EN	Enable input pin. When connected high, the AAT1150 is in normal operation. When connected low, it is powered down. This pin should not be left floating.
4	VCC	Power supply. It supplies power for the internal circuitry.
5	VP	Input supply voltage for converter power stage.
6, 7	LX	Inductor connection pins. These pins should be connected to the output inductor. Internally, Pins 6 and 7 are connected to the drains of the P-channel switch and N-channel synchronous rectifier.
8	PGND	Power ground return for the output stage.

### Pin Configuration

MSOP-8  
(Top View)

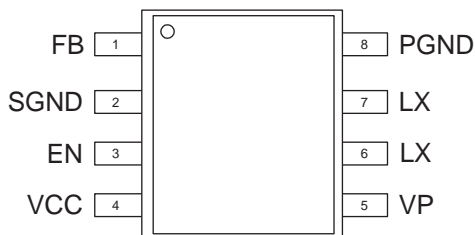

**1MHz 1A Step-Down DC/DC Converter****Absolute Maximum Ratings<sup>1</sup>**

Symbol	Description	Value	Units
$V_{CC}, V_P$	VCC, VP to GND	6	V
$V_{LX}$	LX to GND	-0.3 to $V_P + 0.3$	
$V_{FB}$	FB to GND	-0.3 to $V_{CC} + 0.3$	
$V_{EN}$	EN to GND	-0.3 to 6	
$T_J$	Operating Junction Temperature Range	-40 to 150	°C
$V_{ESD}$	ESD Rating <sup>2</sup> - HBM	3000	V

**Thermal Characteristics<sup>3</sup>**

Symbol	Description	Value	Units
$\theta_{JA}$	Maximum Thermal Resistance	150	°C/W
$P_D$	Maximum Power Dissipation ( $T_A = 25^\circ\text{C}$ ) <sup>4</sup>	667	mW

**Recommended Operating Conditions**

Symbol	Description	Rating	Units
T	Ambient Temperature Range	-40 to +85	°C

1. Stresses above those listed in Absolute Maximum Ratings may cause permanent damage to the device. Functional operation at conditions other than the operating conditions specified is not implied.

2. Human body model is a 100pF capacitor discharged through a 1.5kW resistor into each pin.

3. Mounted on a demo board.

4. Derate 6.7mW/°C above 25°C.

# DATA SHEET

# AAT1150

## 1MHz 1A Step-Down DC/DC Converter

### Electrical Characteristics

$V_{IN} = V_{CC} = V_P = 5V$ ,  $T_A = -40^{\circ}C$  to  $+85^{\circ}C$ , unless otherwise noted. Typical values are at  $T_A = 25^{\circ}C$ .

Symbol	Description	Conditions	Min	Typ	Max	Units
$V_{IN}$	Input Voltage Range		2.7		5.5	V
$V_{OUT}$	Output Voltage Tolerance	$V_{IN} = V_{OUT} + 0.3$ to $5.5V$ , $I_{OUT} = 0$ to $1A$	-4.0		4.0	%
$\frac{\Delta V_{OUT}}{V_{OUT} * \Delta V_{IN}}$	Load Regulation	$V_{IN} = 4.2V$ , $I_{LOAD} = 0$ to $1A$		3.0		
$\frac{\Delta V_{OUT}}{V_{OUT}}$	Line Regulation	$V_{IN} = 2.7V$ to $5.5V$		0.2		%/V
$V_{UVLO}$	Under-Voltage Lockout	$V_{IN}$ Rising			2.5	V
		$V_{IN}$ Falling	1.2			
$V_{UVLO(HYS)}$	Under-Voltage Lockout Hysteresis			250		mV
$I_Q$	Quiescent Supply Current	No Load, $V_{FB} = 0$		160	300	$\mu A$
$I_{SHDN}$	Shutdown Current	$V_{EN} = 0V$ , $V_{IN} = 5.5V$			1.0	
$I_{LIM}$	Current Limit		1.2			A
$R_{DS(ON)H}$	High Side Switch On Resistance	$T_A = 25^{\circ}C$		110	150	m $\Omega$
$R_{DS(ON)L}$	Low Side Switch On Resistance			100	150	
$\eta$	Efficiency	$V_{IN} = 5V$ , $V_{OUT} = 3.3V$ , $I_{OUT} = 600mA$		93		%
$V_{EN(L)}$	Enable Low Voltage	$V_{IN} = 2.7V$ to $5.5V$			0.6	V
$V_{EN(H)}$	Enable High Voltage		1.4			
$I_{EN}$	Enable Pin Leakage Current	$V_{EN} = 5.5V$			1.0	$\mu A$
$F_{OSC}$	Oscillator Frequency	$T_A = 25^{\circ}C$	700	1000	1200	kHz
$T_{SD}$	Over-Temperature Shutdown Threshold			140		$^{\circ}C$
$T_{HYS}$	Over-Temperature Shutdown Hysteresis			15		

### Typical Characteristics

**Efficiency vs. Output Current**  
( $V_{OUT} = 1.5V$ )

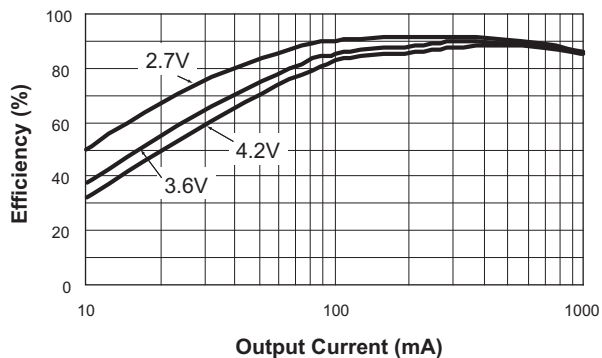

**Efficiency vs. Output Current**  
( $V_{OUT} = 3.3V$ )

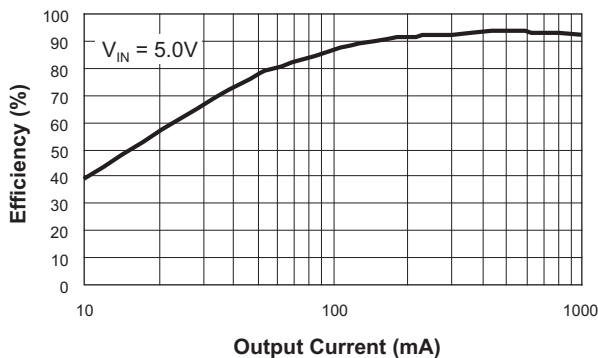

**High Side  $R_{DS(ON)}$  vs. Temperature**

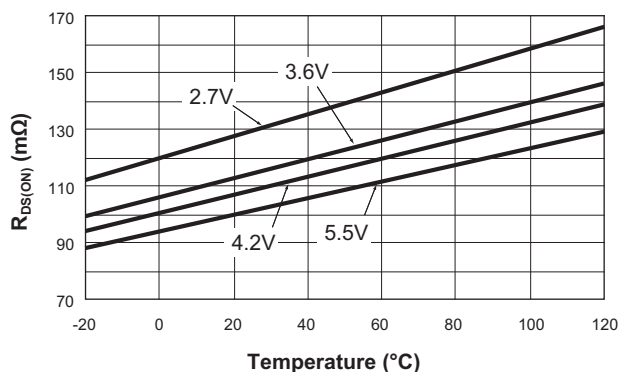

**Low Side  $R_{DS(ON)}$  vs. Temperature**

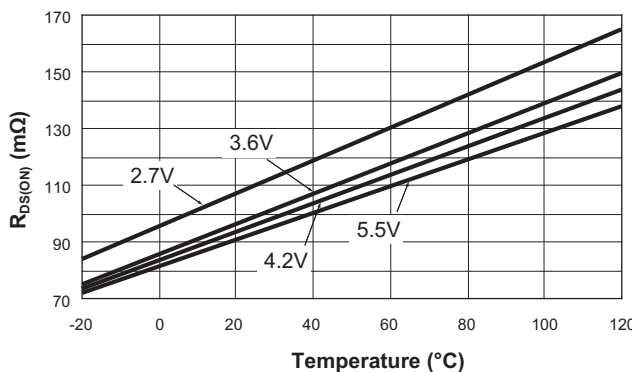

**$R_{DS(ON)}$  vs. Input Voltage**

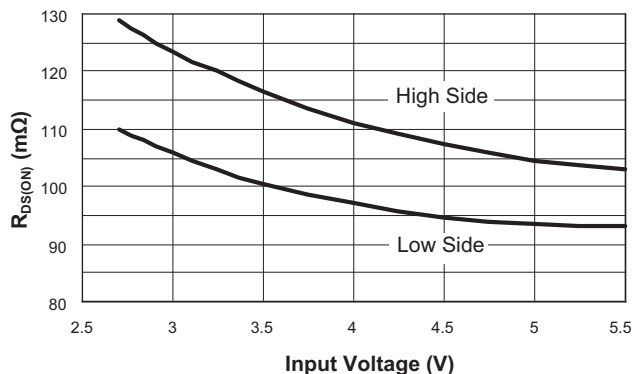

**Enable Threshold vs. Input Voltage**

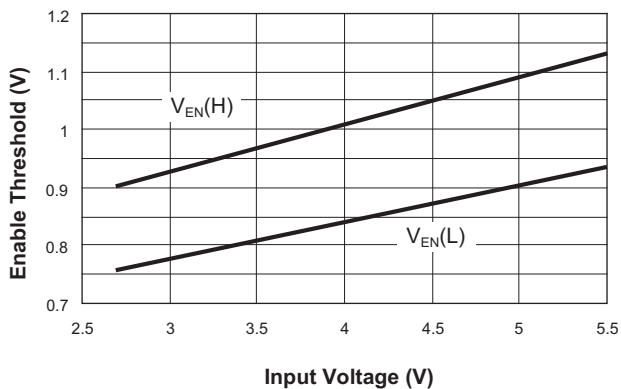

### Typical Characteristics

Oscillator Frequency Variation vs. Supply Voltage

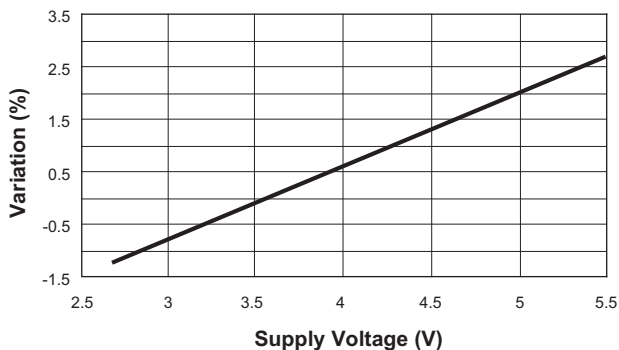

Oscillator Frequency Variation vs. Temperature ( $V_{IN} = 3.6V$ )

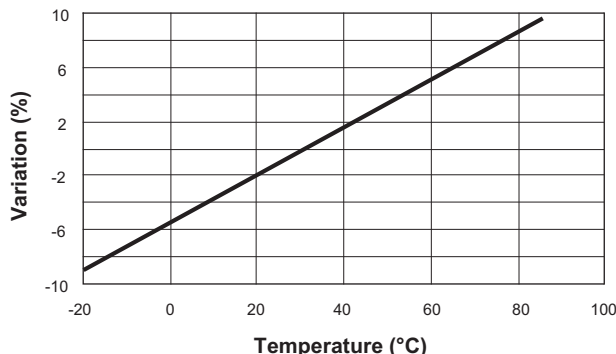

Output Voltage vs. Temperature ( $I_{OUT} = 900mA$ ;  $V_{OUT} = 1.5V$ )

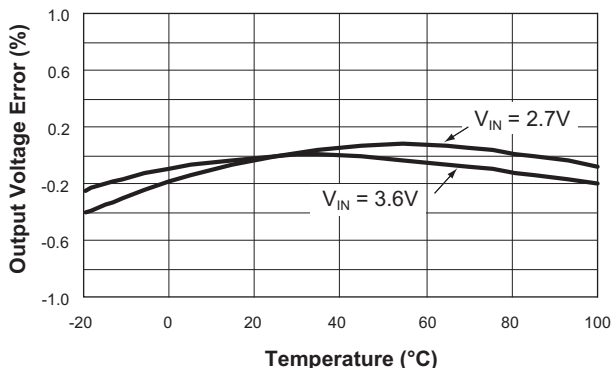

Line Regulation ( $V_{OUT} = 1.5V$ )

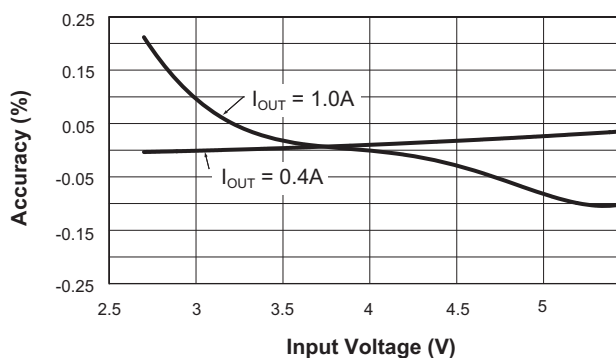

Load Regulation ( $V_{OUT} = 1.5V$ ;  $V_{IN} = 3.6V$ )

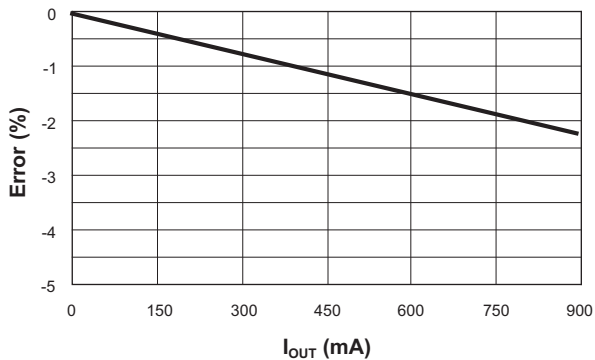

Load Regulation ( $V_{OUT} = 3.3V$ ;  $V_{IN} = 5.0V$ )

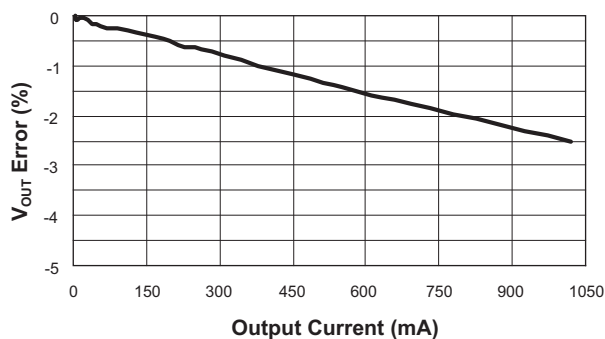

# AAT1150

## 1MHz 1A Step-Down DC/DC Converter

### Typical Characteristics

**Efficiency vs. Input Voltage**  
( $V_{OUT} = 1.5V$ )

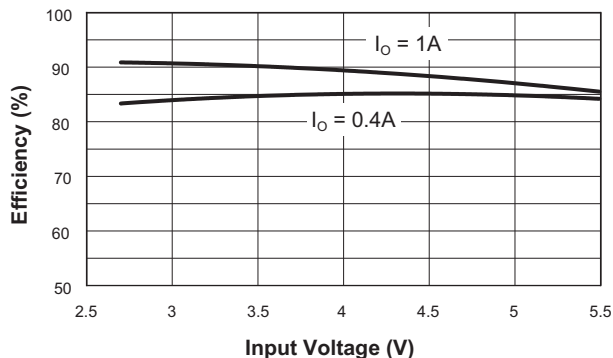

**AAT1150 Loop Gain and Phase**  
( $C_o = 22\mu F$ ;  $V_o = 1.5V$ ;  $V_{IN} = 3.6V$ ;  $I_o = 1A$ )

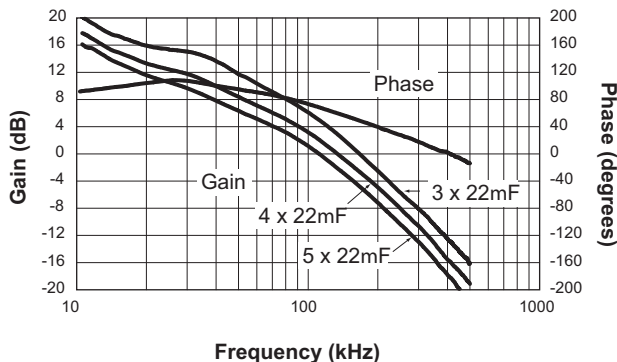

**No Load Input Current vs. Temperature**  
( $V_{CC} = V_P$ )

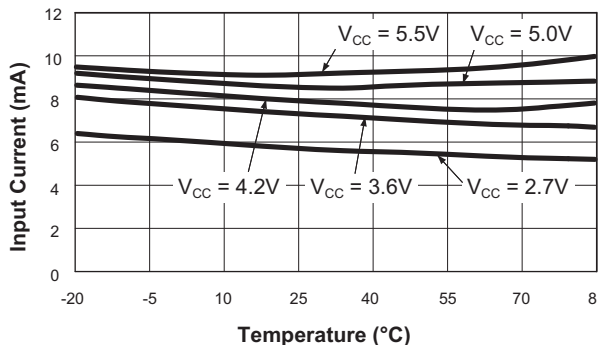

**Non-Switching  $I_Q$  vs. Temperature**  
( $FB = 0V$ ;  $V_P = V_{CC}$ )

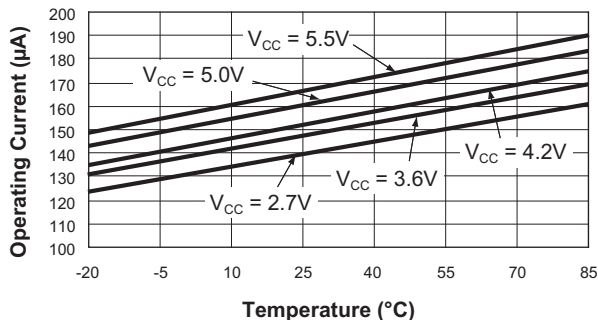

**Switching Waveform**  
( $V_{IN} = 3.6V$ ;  $V_{OUT} = 1.5V$ ;  $I_{OUT} = 1.2A$ )

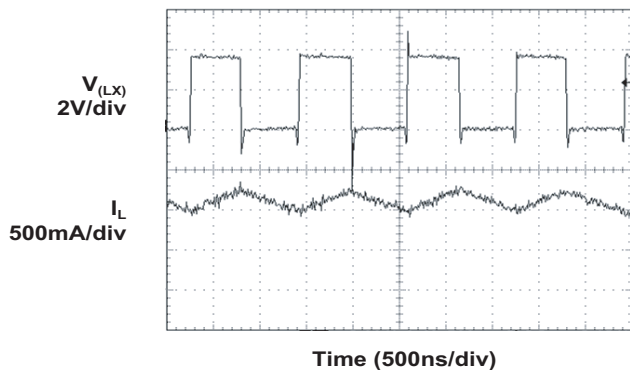

**Transient Response**  
( $V_{IN} = 3.6V$ ;  $V_{OUT} = 1.5V$ ;  $I_{LOAD} = 0.25$  to  $1.2A$ )

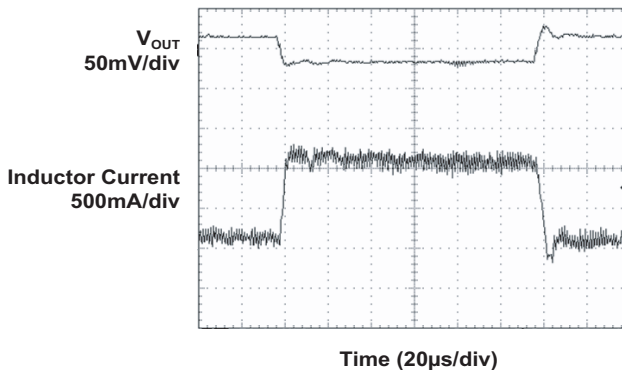

### Typical Characteristics

#### Output Ripple

( $V_{IN} = 3.6V$ ;  $V_{OUT} = 1.5V$ ;  $I_{OUT} = 0A$ )



Time (500ns/div)

#### Output Ripple

( $V_{IN} = 3.6V$ ;  $V_{OUT} = 1.5V$ ;  $I_{OUT} = 1A$ )

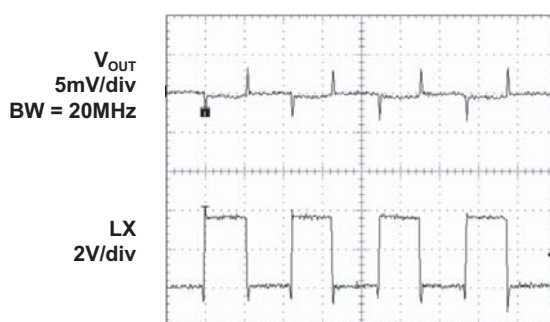

Time (500ns/div)

#### Output Ripple

( $V_{IN} = 5.0V$ ;  $V_{OUT} = 3.3V$ ;  $I_{OUT} = 0A$ )

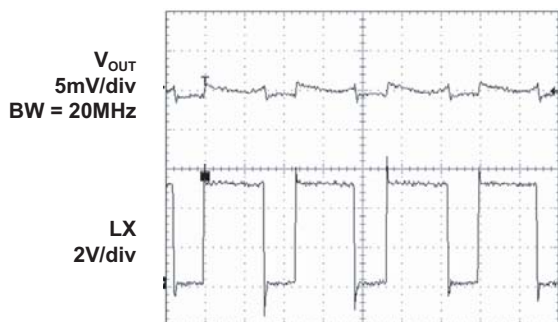

Time (500ns/div)

#### Output Ripple

( $V_{IN} = 5.0V$ ;  $V_{OUT} = 3.3V$ ;  $I_{OUT} = 1A$ )

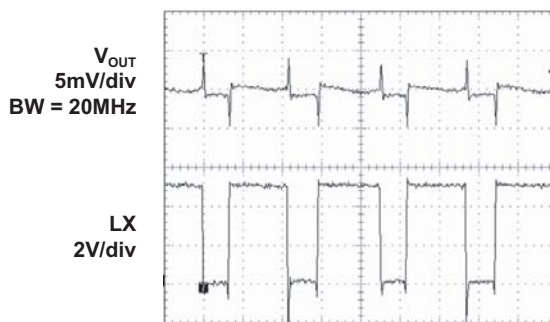

Time (500ns/div)

#### Inrush Limit

( $V_{IN} = 3.6V$ ;  $V_{OUT} = 1.5V$ ;  $I_L = 1A$ )

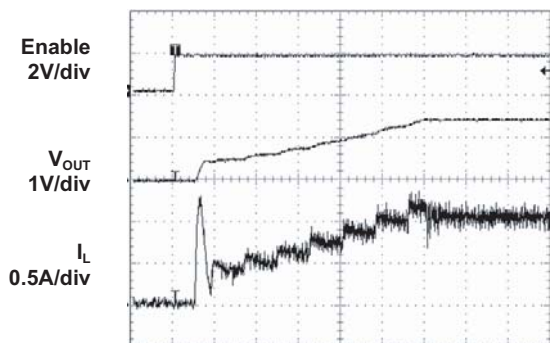

Time (200 $\mu$ s/div)

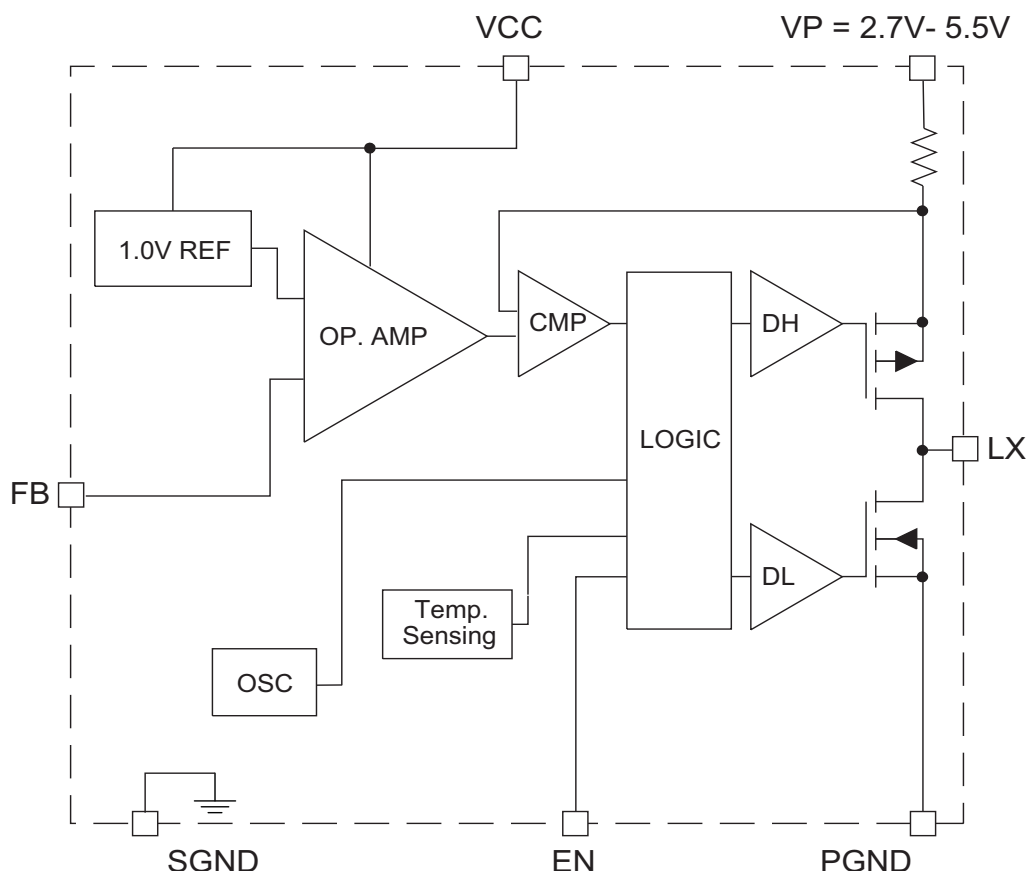

**Functional Block Diagram****Applications Information****Control Loop**

The AAT1150 is a peak current mode buck converter. The inner wide bandwidth loop controls the peak current of the output inductor. The output inductor current is sensed through the P-channel MOSFET (high side) and is also used for short-circuit and overload protection. A fixed slope compensation signal is added to the sensed current to maintain stability. The loop appears as a voltage-programmed current source in parallel with the output capacitor.

The voltage error amplifier output programs the current loop for the necessary inductor current to force a constant output voltage for all load and line conditions. The feedback resistive divider is external, dividing the output

voltage to the error amplifier reference voltage of 1.0V. The error amplifier does not have a large DC gain typical of most error amplifiers. This eliminates the need for external compensation components while still providing sufficient DC loop gain for load regulation. The crossover frequency and phase margin are set by the output capacitor value only.

**Soft Start/Enable**

Soft start increases the inductor current limit point in discrete steps when the input voltage or enable input is applied. It limits the current surge seen at the input and eliminates output voltage overshoot. The enable input, when pulled low, forces the AAT1150 into a low power, non-switching state. The total input current during shutdown is less than 1 $\mu$ A.

## 1MHz 1A Step-Down DC/DC Converter

### Power and Signal Source

Separate small signal ground and power supply pins isolate the internal control circuitry from the noise associated with the output MOSFET switching. The low pass filter R1 and C7 in schematic Figures 1 and 2 filters the noise associated with the power switching.

### Current Limit and Over-Temperature Protection

For overload conditions, the peak input current is limited. Figure 3 displays the current limit characteristics. As load impedance decreases and the output voltage falls closer to zero, more power is dissipated internally, raising the device temperature. Thermal protection completely disables switching when internal dissipation becomes excessive, protecting the device from damage. The junction over-temperature threshold is 140°C with 15°C of hysteresis.

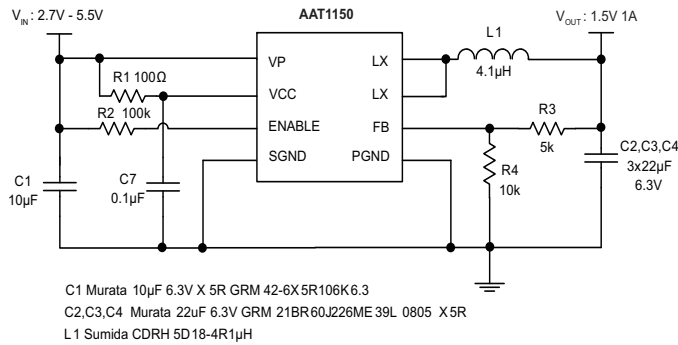

Figure 1: Lithium-Ion to 1.5V Converter.

Efficiency vs. Output Current  
(V<sub>OUT</sub> = 1.5V)

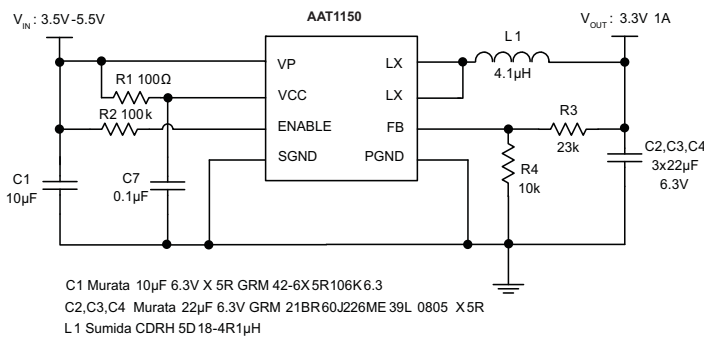
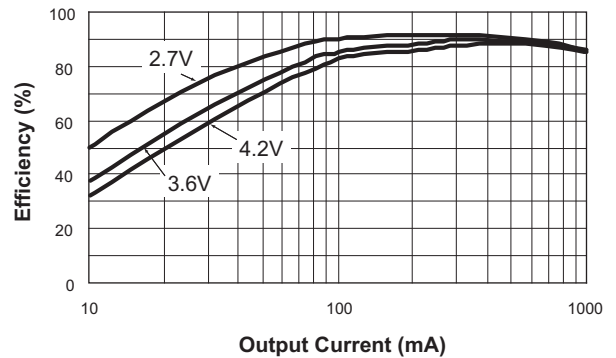
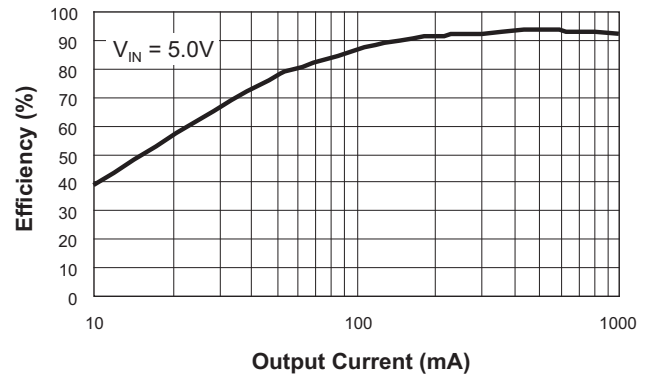

Figure 2: 5V Input to 3.3V Output Converter.

Efficiency vs. Output Current  
(V<sub>OUT</sub> = 3.3V)



## 1MHz 1A Step-Down DC/DC Converter

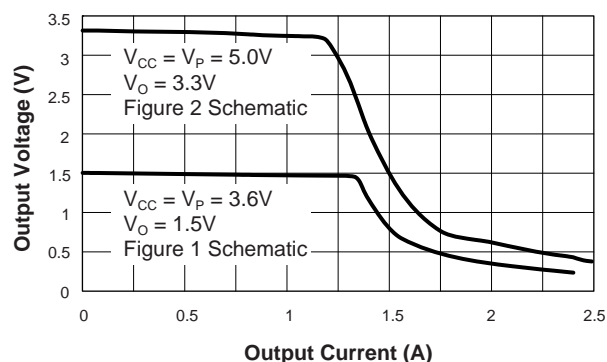

Figure 3: Current Limit Characteristics.

### Inductor

The output inductor is selected to limit the ripple current to some predetermined value, typically 20% to 40% of the full load current at the maximum input voltage. Manufacturer's specifications list both the inductor DC current rating, which is a thermal limitation, and the peak current rating, which is determined by the saturation characteristics. The inductor should not show any appreciable saturation under normal load conditions. During overload and short-circuit conditions, the average current in the inductor can meet or exceed the  $I_{LIMIT}$  point of the AAT1150 without affecting converter performance. Some inductors may have sufficient peak and average current ratings yet result in excessive losses due to a high DCR. Always consider the losses associated with the DCR and its effect on the total converter efficiency when selecting an inductor.

For a 1.0A load and the ripple set to 30% at the maximum input voltage, the maximum peak-to-peak ripple current is 300mA. The inductance value required is 3.9 $\mu$ H.

$$L = \frac{V_{OUT}}{I_O \cdot k \cdot F_S} \cdot \left(1 - \frac{V_{OUT}}{V_{IN}}\right)$$

$$L = \frac{1.5V}{1.0A \cdot 0.3 \cdot 830kHz} \cdot \left(1 - \frac{1.5V}{4.2V}\right)$$

$$L = 3.9\mu H$$

The factor "k" is the fraction of full load selected for the ripple current at the maximum input voltage. The corresponding inductor RMS current is:

$$I_{RMS} = \sqrt{\left(I_O^2 + \frac{\Delta I^2}{12}\right)} \approx I_O = 1.0A$$

$\Delta I$  is the peak-to-peak ripple current which is fixed by the inductor selection above. For a peak-to-peak current of 30% of the full load current, the peak current at full load will be 115% of the full load. The 4.1 $\mu$ H inductor selected from the Sumida CDRH5D18 series has a 57m $\Omega$  DCR and a 1.95A DC current rating. At full load, the inductor DC loss is 57mW which amounts to a 3.8% loss in efficiency.

### Input Capacitor

The primary function of the input capacitor is to provide a low impedance loop for the edges of pulsed current drawn by the AAT1150. A low ESR/ESL ceramic capacitor is ideal for this function. To minimize stray inductance, the capacitor should be placed as closely as possible to the IC. This keeps the high frequency content of the input current localized, minimizing radiated and conducted EMI while facilitating optimum performance of the AAT1150. Ceramic X5R or X7R capacitors are ideal for this function. The size required will vary depending on the load, output voltage, and input voltage source impedance characteristics. A typical value is around 10 $\mu$ F. The input capacitor RMS current varies with the input voltage and the output voltage. The equation for the RMS current in the input capacitor is:

$$I_{RMS} = I_O \cdot \sqrt{\frac{V_O}{V_{IN}} \cdot \left(1 - \frac{V_O}{V_{IN}}\right)}$$

The input capacitor RMS ripple current reaches a maximum when  $V_{IN}$  is two times the output voltage where it is approximately one half of the load current. Losses associated with the input ceramic capacitor are typically minimal and are not an issue. Proper placement of the input capacitor can be seen in the reference design layout shown in Figures 4 and 5.

**1MHz 1A Step-Down DC/DC Converter****Output Capacitor**

Since there are no external compensation components, the output capacitor has a strong effect on loop stability. Larger output capacitance will reduce the crossover frequency with greater phase margin. For the 1.5V 1.0A design using the 4.1μH inductor, three 22μF 6.3V X5R capacitors provide a stable output. In addition to assisting stability, the output capacitor limits the output ripple and provides holdup during large load transitions.

The output capacitor RMS ripple current is given by:

$$I_{\text{RMS}} = \frac{1}{2 \cdot \sqrt{3}} \cdot \frac{V_{\text{OUT}} \cdot (V_{\text{IN}} - V_{\text{OUT}})}{L \cdot F_{\text{S}} \cdot V_{\text{IN}}}$$

For a ceramic capacitor, the dissipation due to the RMS current of the capacitor is not a concern. Tantalum capacitors, with sufficiently low ESR to meet output voltage ripple requirements, also have an RMS current rating much greater than that actually seen in this application.

**Adjustable Output**

For applications requiring an output other than 1V, the AAT1150 can be externally programmed. Resistors R3 and R4 of Figure 6 force the output to regulate higher than 1V. R4 should be 100 times less than the internal 1MΩ resistance of the FB pin. Once R4 is selected, R3 can be calculated. For a 1.25V output with R4 set to 10.0kΩ, R3 is 2.55kΩ.

$$R3 = (V_{\text{O}} - 1) \cdot R4 = 0.25 \cdot 10.0\text{k}\Omega = 2.55\text{k}\Omega$$

**Layout Considerations**

Figures 4 and 5 display the suggested PCB layout for the AAT1150. The most critical aspect of the layout is the placement of the input capacitor C1. For proper operation, C1 must be placed as closely as possible to the AAT1150.

**Thermal Calculations**

There are two types of losses associated with the AAT1150 output switching MOSFET: switching losses and conduction losses. Conduction losses are associated with the  $R_{\text{DS(ON)}}$  characteristics of the output switching device. At full load, assuming continuous conduction mode (CCM), a simplified form of the total losses is:

$$P_{\text{LOSS}} = \frac{I_{\text{O}}^2 \cdot (R_{\text{DS(ON)H}} \cdot V_{\text{O}} + R_{\text{DS(ON)L}} \cdot (V_{\text{IN}} - V_{\text{O}}))}{V_{\text{IN}}} + t_{\text{sw}} \cdot F_{\text{S}} \cdot I_{\text{O}} \cdot V_{\text{IN}} + I_{\text{Q}} \cdot V_{\text{IN}}$$

Once the total losses have been determined, the junction temperature can be derived from the  $\Theta_{\text{JA}}$  for the MSOP-8 package.

*1MHz 1A Step-Down DC/DC Converter*

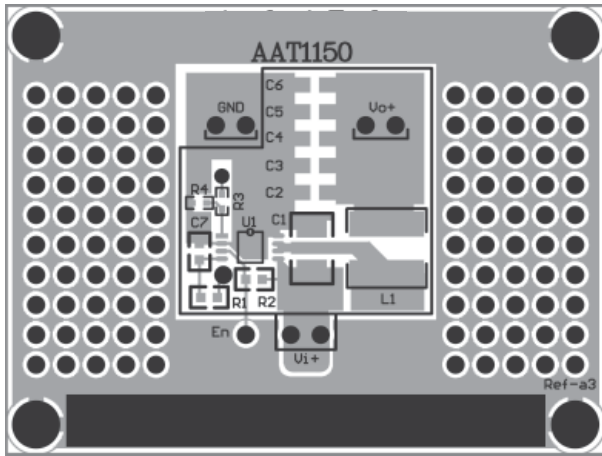

**Figure 4: AAT1150 Evaluation Board Layout Top Layer.**

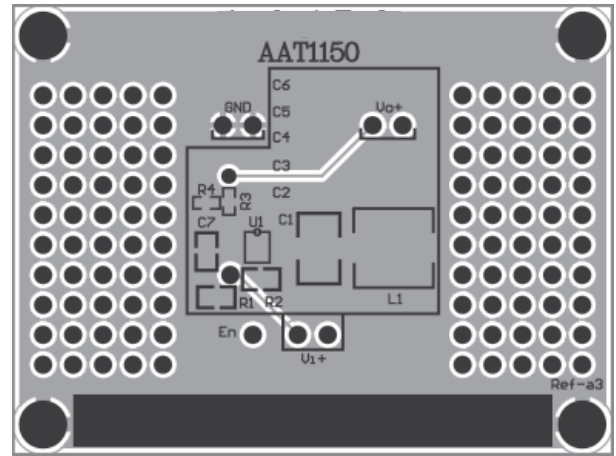

**Figure 5: AAT1150 Evaluation Board Layout Bottom Layer.**

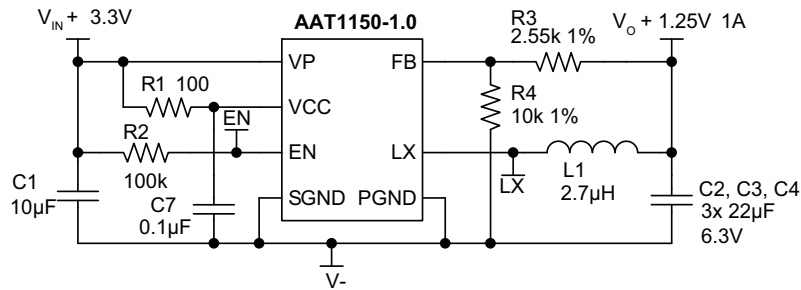

C1 Murata 10µF 6.3V X5R GRM42-6X 5R106K6.3  
 C2, C3, C4 MuRata 22µF 6.3V GRM21BR60J226ME39L X5R 0805  
 L1 Sumida CDRH4D28-2R7µH

**Figure 6: 3.3V to 1.25V Converter (Adjustable Output).**

**Design Example****Specifications**

$$I_{OUT} = 1.0A$$

$$I_{RIPPLE} = 30\% \text{ of Full Load at Max } V_{IN}$$

$$V_{OUT} = 1.5V$$

$$V_{IN} = 2.7V \text{ to } 4.2V \text{ (3.6V nominal)}$$

$$F_s = 830kHz$$

**Maximum Input Capacitor Ripple**

$$I_{RMS} = I_O \cdot \sqrt{\frac{V_O}{V_{IN}} \cdot \left(1 - \frac{V_O}{V_{IN}}\right)} = \frac{I_O}{2} = 0.5A_{RMS}, V_{IN} = 2 \cdot V_O$$

$$P = ESR_{COUT} \cdot I_{RMS}^2 = 5m\Omega \cdot 0.5^2 A = 1.25mW$$

**Inductor Selection**

$$L = \frac{V_{OUT}}{I_O \cdot k \cdot F_s} \cdot \left(1 - \frac{V_{OUT}}{V_{IN}}\right) = \frac{1.5V}{1.0A \cdot 0.3 \cdot 830kHz} \cdot \left(1 - \frac{1.5V}{4.2V}\right) = 3.9\mu H$$

Select Sumida inductor CDRH5D18, 4.1 $\mu$ H, 57m $\Omega$ , 2.0mm height.

$$\Delta I = \frac{V_O}{L \cdot F_s} \cdot \left(1 - \frac{V_O}{V_{IN}}\right) = \frac{1.5V}{4.1\mu H \cdot 830kHz} \cdot \left(1 - \frac{1.5V}{4.2V}\right) = 280mA$$

$$I_{PK} = I_{OUT} + \frac{\Delta I}{2} = 1.0A + 0.14A = 1.14A$$

$$P = I_O^2 \cdot DCR = 57mW$$

**Output Capacitor Dissipation**

$$I_{RMS} = \frac{1}{2 \cdot \sqrt{3}} \cdot \frac{V_{OUT} \cdot (V_{IN} - V_{OUT})}{L \cdot F_s \cdot V_{IN}} = \frac{1}{2 \cdot \sqrt{3}} \cdot \frac{1.5V \cdot (4.2V - 1.5V)}{4.1\mu H \cdot 830kHz \cdot 4.2V} = 82mA_{RMS}$$

$$P_{ESR} = ESR_{COUT} \cdot I_{RMS}^2 = 5m\Omega \cdot 0.082^2 A = 33\mu W$$

**AAT1150 Dissipation**

$$P = \frac{I_O^2 \cdot (R_{DS(ON)H} \cdot V_O + R_{DS(ON)L} \cdot (V_{IN} - V_O))}{V_{IN}} + (t_{sw} \cdot F_S \cdot I_O + I_Q) \cdot V_{IN}$$

$$= \frac{(0.14\Omega \cdot 1.5V + 0.145\Omega \cdot (3.6V - 1.5V))}{3.6V} + (20\text{nsec} \cdot 830\text{kHz} \cdot 1.0A + 0.3\text{mA}) \cdot 3.6V = 0.203W$$

$$T_{J(MAX)} = T_{AMB} + \Theta_{JA} \cdot P_{LOSS} = 85^\circ\text{C} + 150^\circ\text{C/W} \cdot 0.203W = 115^\circ\text{C}$$

Manufacturer	Part Number	Value	Max DC Current	DCR	Size (mm) L x W x H	Type
Taiyo Yuden	NPO5DB4R7M	4.7 $\mu$ H	1.4A	0.038	5.9 x 6.1 x 2.8	Shielded
Toko	A914BYW-3R5M-D52LC	3.5 $\mu$ H	1.34A	0.073	5.0 x 5.0 x 2.0	
Sumida	CDRH5D28-4R2	4.2 $\mu$ H	2.2A	0.031	5.7 x 5.7 x 3.0	
	CDRH5D18-4R1	4.1 $\mu$ H	1.95A	0.057	5.7 x 5.7 x 2.0	
Murata	LQH55DN4R7M03	4.7 $\mu$ H	2.7A	0.041	5.0 x 5.0 x 4.7	Non-Shielded
	LQH66SN4R7M03		2.2A	0.025	6.3 x 6.3 x 4.7	Shielded

Table 1: Surface Mount Inductors.

Manufacturer	Part Number	Value	Voltage	Temp. Co.	Case
Murata	GRM40 X5R 106K 6.3	10 $\mu$ F	6.3V	X5R	0805
	GRM42-6 X5R 106K 6.3				1206
	GRM21BR60J226ME39L	22 $\mu$ F			0805
	GRM21BR60J106ME39L	10 $\mu$ F			

Table 2: Surface Mount Capacitors.

# AAT1150

## 1MHz 1A Step-Down DC/DC Converter

### Ordering Information

Output Voltage	Package	Marking <sup>1</sup>	Part Number (Tape & Reel) <sup>2</sup>
1.0V (Adj V <sub>OUT</sub> ≥ 1.0V)	MSOP-8	JZXYY	<b>AAT1150IKS-1.0-T1</b>



Skyworks Green™ products are compliant with all applicable legislation and are halogen-free. For additional information, refer to Skyworks Definition of Green™, document number SQ04-0074.

### Package Information

#### MSOP-8

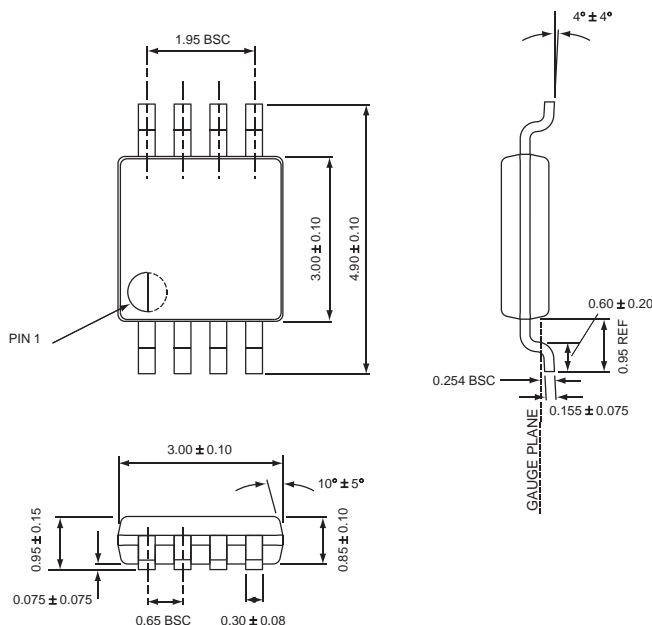

All dimensions in millimeters.

1. XYY = assembly and date code.
2. Sample stock is held on part numbers listed in **BOLD**.

Copyright © 2012 Skyworks Solutions, Inc. All Rights Reserved.

Information in this document is provided in connection with Skyworks Solutions, Inc. ("Skyworks") products or services. These materials, including the information contained herein, are provided by Skyworks as a service to its customers and may be used for informational purposes only by the customer. Skyworks assumes no responsibility for errors or omissions in these materials or the information contained herein. Skyworks may change its documentation, products, services, specifications or product descriptions at any time, without notice. Skyworks makes no commitment to update the materials or information and shall have no responsibility whatsoever for conflicts, incompatibilities, or other difficulties arising from any future changes.

No license, whether express, implied, by estoppel or otherwise, is granted to any intellectual property rights by this document. Skyworks assumes no liability for any materials, products or information provided hereunder, including the sale, distribution, reproduction or use of Skyworks products, information or materials, except as may be provided in Skyworks Terms and Conditions of Sale.

THE MATERIALS, PRODUCTS AND INFORMATION ARE PROVIDED "AS IS" WITHOUT WARRANTY OF ANY KIND, WHETHER EXPRESS, IMPLIED, STATUTORY, OR OTHERWISE, INCLUDING FITNESS FOR A PARTICULAR PURPOSE OR USE, MERCHANTABILITY, PERFORMANCE, QUALITY OR NON-INFRINGEMENT OF ANY INTELLECTUAL PROPERTY RIGHT; ALL SUCH WARRANTIES ARE HEREBY EXPRESSLY DISCLAIMED. SKYWORKS DOES NOT WARRANT THE ACCURACY OR COMPLETENESS OF THE INFORMATION, TEXT, GRAPHICS OR OTHER ITEMS CONTAINED WITHIN THESE MATERIALS. SKYWORKS SHALL NOT BE LIABLE FOR ANY DAMAGES, INCLUDING BUT NOT LIMITED TO ANY SPECIAL, INDIRECT, INCIDENTAL, STATUTORY, OR CONSEQUENTIAL DAMAGES, INCLUDING WITHOUT LIMITATION, LOST REVENUES OR LOST PROFITS THAT MAY RESULT FROM THE USE OF THE MATERIALS OR INFORMATION, WHETHER OR NOT THE RECIPIENT OF MATERIALS HAS BEEN ADVISED OF THE POSSIBILITY OF SUCH DAMAGE.

Skyworks products are not intended for use in medical, lifesaving or life-sustaining applications, or other equipment in which the failure of the Skyworks products could lead to personal injury, death, physical or environmental damage. Skyworks customers using or selling Skyworks products for use in such applications do so at their own risk and agree to fully indemnify Skyworks for any damages resulting from such improper use or sale.

Customers are responsible for their products and applications using Skyworks products, which may deviate from published specifications as a result of design defects, errors, or operation of products outside of published parameters or design specifications. Customers should include design and operating safeguards to minimize these and other risks. Skyworks assumes no liability for applications assistance, customer product design, or damage to any equipment resulting from the use of Skyworks products outside of stated published specifications or parameters.

Skyworks, the Skyworks symbol, and "Breakthrough Simplicity" are trademarks or registered trademarks of Skyworks Solutions, Inc., in the United States and other countries. Third-party brands and names are for identification purposes only, and are the property of their respective owners. Additional information, including relevant terms and conditions, posted at [www.skyworksinc.com](http://www.skyworksinc.com), are incorporated by reference.