

SPECIFICATIONS

Rated Current:1.5AMP
 Contact Resistance:20mΩ Max
 Withstand Voltage:500V AC/DC
 Insulation Resistance:1000MΩ Min
 Operation Temperature:-40°C to +105°C

Contact Material:Brass
 Contact Plating:Au or Sn Over Ni
 Insulator Material:Polyester(UL94V-0)
 Standard: PA6T
 Max.Processing Temp: 230°C for 30-60 seconds
 (260°C for 5 seconds)

Recommended P.C.B Layout(Top Side)
 (PCB BOARD TOLERANCE±0.05)

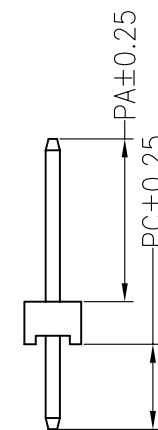
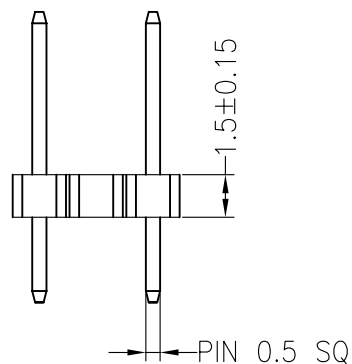
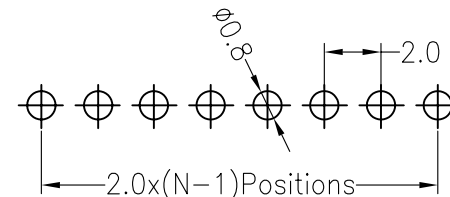
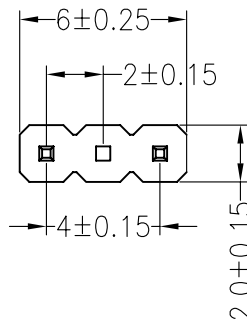

Dimension antitheses list			
ITEM	PC	PA	L
Standard	3.00	7.00	11.50

OPERATION

X.X	±0.30
X.XX	±0.20
X.XXX	±0.10
Angle	±3°
DIM	TOL

DRAW
CHECK
APPROVE

YiYuSheng

12.04.11

SCALE
UNIT
SIZE
SHEET
PROJ.

FIT
mm
A4
1/1
◆ ↗

KLS ELECTRONIC CO., LTD

PART NO. L-KLS1-207B-1.5-1-03P1K-S-3.0*7.0*11.5

TITLE: 2.0PH 1xNpin H1.5mm Single 180°

REV	DATE	MODIFICATION DESCRIPTION	CHANGE
A0	2012.04.11	NEW DRAWING	