

AHI-JS-DR-02-357

MARK	ECN	DESCRIPTION	DWN.	DATE

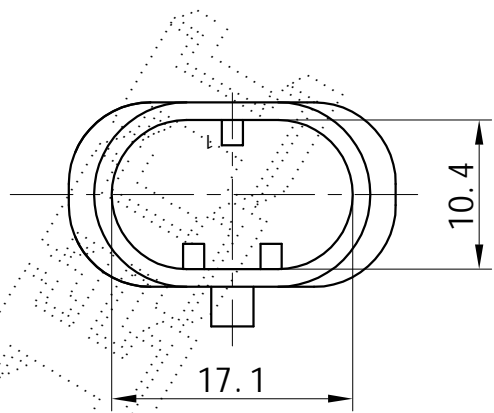
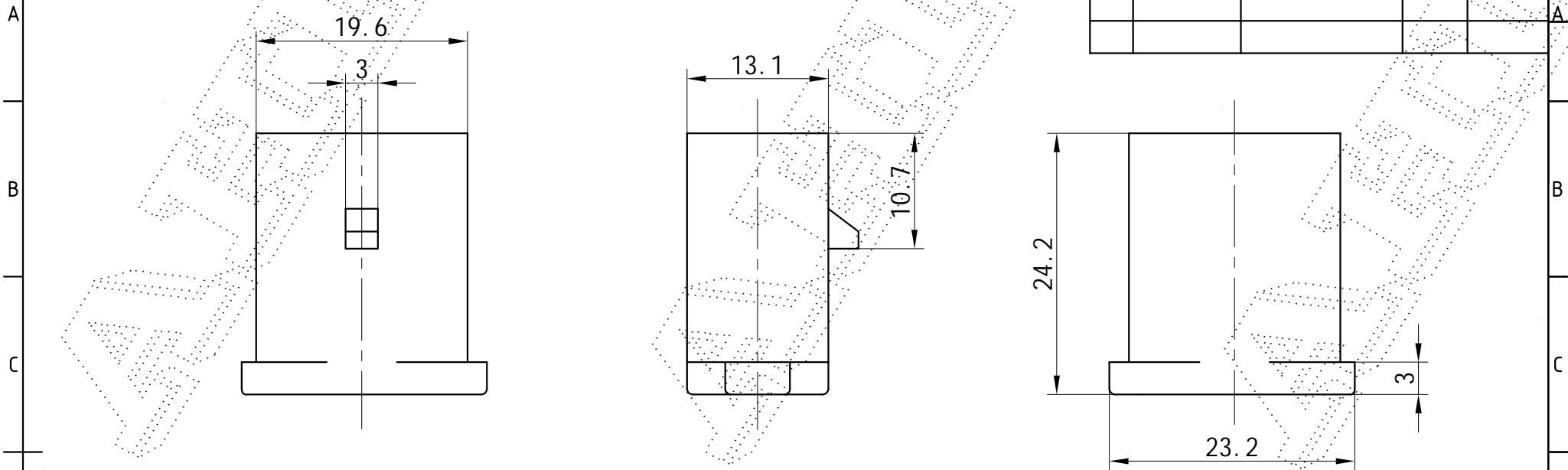

Technical requirements

1. Parts must not have burr and injection molding defects which affect usability
2. The surface is bright and clean, smooth, no waterlogging, etc
3. The "◆" is the important feature, "★" is the key features
4. Unmarked tolerance dimensions carry out according to the GB - T14486-2008 - MT6 level

NO. TOLERANCES GB/T14486-2008-MT6			
DIM. RANGE	DIM. TOLERANCES	DIM. RANGE	DIM. TOLERANCES
0~3	±0.23	>18~24	±0.41
>3~6	±0.26	>24~30	±0.45
>6~10	±0.29	>30~40	±0.50
>10~14	±0.33	>40~50	±0.57
>14~18	±0.37	>50~65	±0.65

COLOUR	BLACK	乐清市奥海电气有限公司 AHI		
MATERIAL	PA66	Yueqing Aohai Electric Co., Ltd.		
NAME	2HOLE COVER	DRAWN BY	CONFIRMED BY	APPROVED BY
PART NO.	DJ7021-1.5-20	长	AHI	程
TYPE		乐清市奥海电气有限公司 技术部		
ARTICLE NO.		REV.	1st: 1.0	UNIT
MOULD NO.:		1.0	mm	PAGE
				1/2