

MARK	ECN	DESCRIPTION	DWN.	DATE

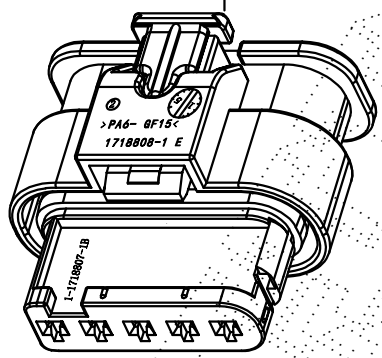

Technical requirements

1. Parts must not have burr and injection molding defects which affect usability
2. The surface is bright and clean, smooth, no waterlogging, etc
3. The "◆" is the important feature, "★" is the key features
4. Unmarked tolerance dimensions carry out according to the GB - T14486-2008 - MT6 level
5. The mating terminal is DJ621-1.2A

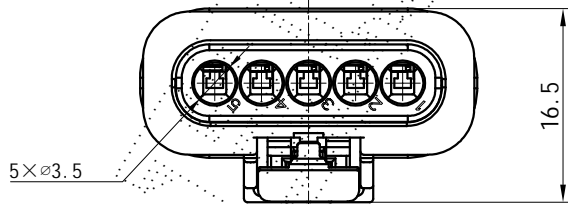
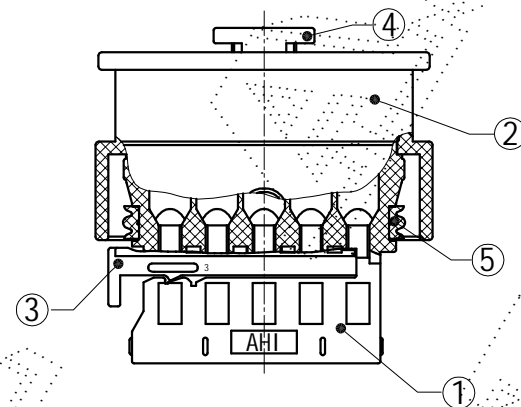
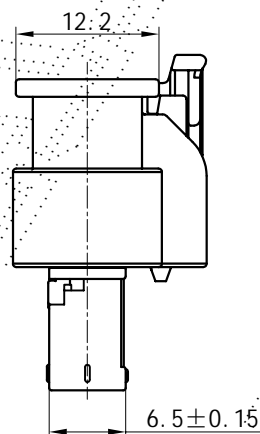
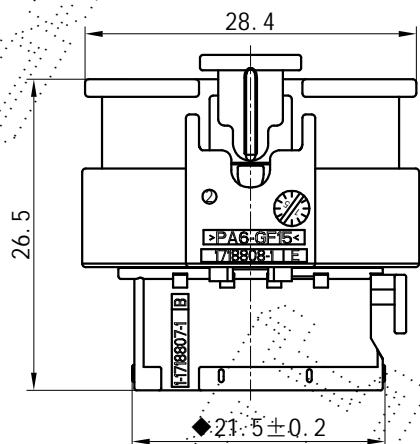
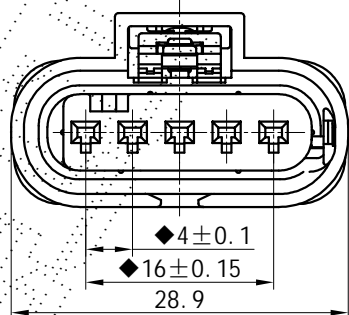

COLOUR	BLACK	乐清市奥海电气有限公司			
MATERIAL	SEE TABLE	AHI Yueqing Aohai Electric Co., Ltd.			
NAME	5HOLE CONNECTOR	DRAWN BY	CONFIRMED BY	APPROVED BY	
PART NO.	DJ7055-1.2-21				
TYPE					
ARTICLE NO.		REV.	1st PERSON VIEW	FREE	UNIT
MOULD NO.:		1.0		1:1	mm
					PAGE
					1/1

NO. TOLERANCES GB/T14486-2008-MT6				⑤	④	③	②	①	NO.	PART NO.	NAME	MATERIAL	Q' TY	COLOUR
DIM. RANGE	DIM. TOLERANCES	DIM. RANGE	DIM. TOLERANCES											
0~3	±0.23	>18~24	±0.41	⑤	④	③	②	①			WIRE SEAL	SILICONE RUBBER	1	TRANSPARENT
>3~6	±0.26	>24~30	±0.45								LOCK	PA66	1	GREY
>6~10	±0.29	>30~40	±0.50								HOLDER	PA66+GF	1	PURPLE
>10~14	±0.33	>40~50	±0.57								COVER	PA66+GF	1	BLACK
>14~18	±0.37	>50~65	±0.65								HOUSING	PA66+GF	1	BLACK