

MARK	ECN	DESCRIPTION	DATE

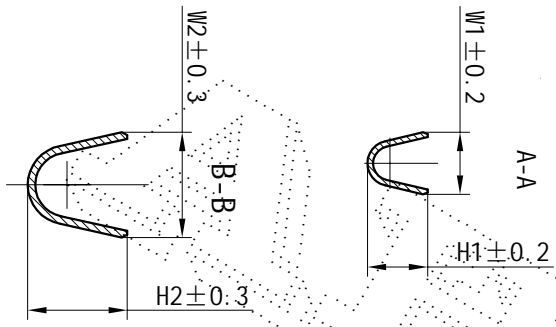
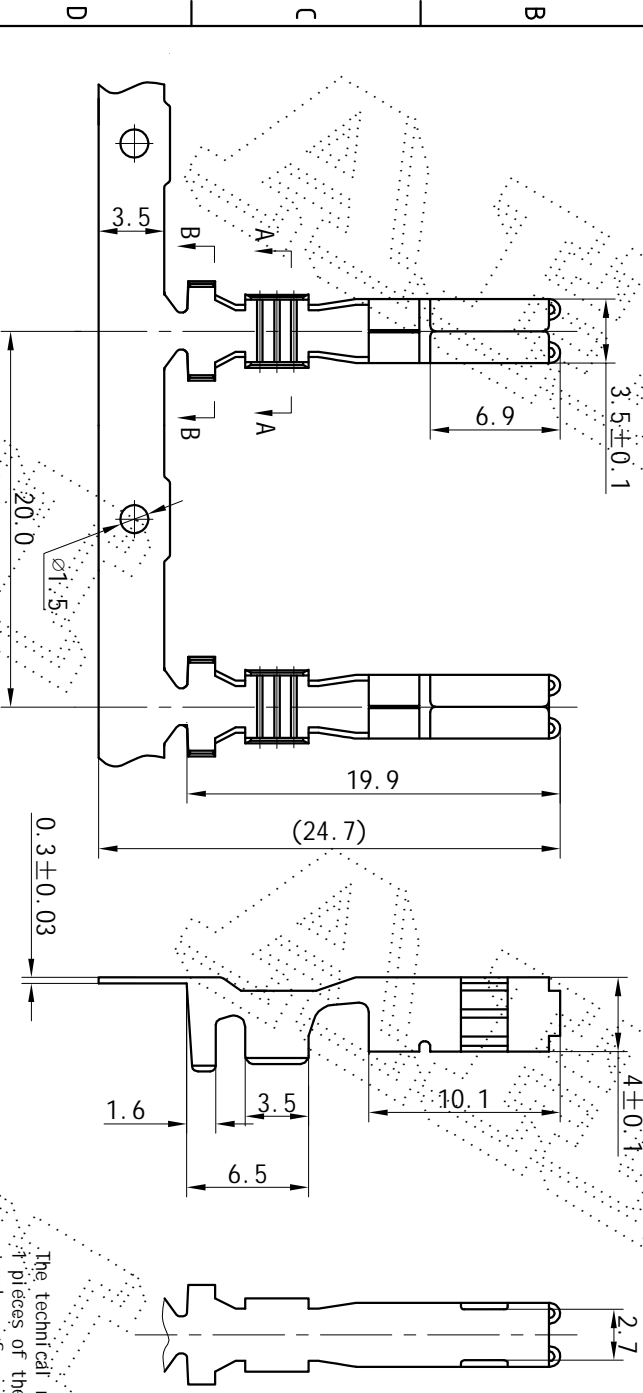

The technical requirements:
 1. pieces of the surface are not allowed to have obvious scratches, cracks, eformation
 Stamping defects, chamfer is clear, stamping Feng is less than 0.02mm
 2. not note round R R0.2 to R0.5mm
 3. product beading and striffener depth 0.08-0.1mm
 4. "*" is the important characteristic, "i" "As the key" characteristics.
 5. did not note the size tolerance in table GB/T15055-2007

NO. TOLERANCES GB/T15055-2007-m		DIM. TOLERANCES:		NO.		TYPE		PART NO.		W1		W2		H1		H2	
DIM. RANGE	DIM. TOLERANCES:	1	2	1	2	1	2	1	2	1	2	1	2	1	2	1	2
0.5~3	±0.20	1	2	1	2	1	2	1	2	1	2	1	2	1	2	1	2
>3~6	±0.30	1	2	1	2	1	2	1	2	1	2	1	2	1	2	1	2
>6~30	±0.40	1	2	1	2	1	2	1	2	1	2	1	2	1	2	1	2
>30~120	±0.50	1	2	1	2	1	2	1	2	1	2	1	2	1	2	1	2

SURFACE TREATMENT	TIN-PLATED
MATERIAL	COPPER TO.3
NAME	TERMINAL
PART NO.	DJ627-2.8X0.8A
ARTICLE NO.	DJ627-2.8*0.8C
MOULD NO.:	

REV.	1st-PERSON-VIEW	FREE	UNIT	PAGE
1.0		2.5:1	mm	1/1

AHEI 乐清市奥海电气有限公司
 Yueqing Aohai Electric Co., Ltd.

DRAWN BY: CONFIRMED BY APPROVED BY

2011.5.28