

Current Transducer LTC 1000-S

For the electronic measurement of currents: DC, AC, pulsed..., with galvanic isolation between the primary circuit and the secondary circuit.

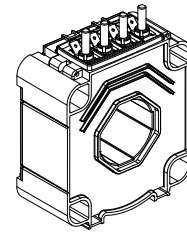

$$I_{PN} = 1000 \text{ A}$$



Electrical data

I_{PN}	Primary nominal current rms	1000	A	
I_{PM}	Primary current, measuring range @ $\pm 24 \text{ V}$	$0 \dots \pm 2400$ ¹⁾	A	
\hat{I}_P	Overload capability	10 / 10	kA/ms	
R_M	Measuring resistance	$R_{M \min}$ $R_{M \max}$		
			with $\pm 15 \text{ V}$	@ $\pm 1000 \text{ A}_{\max}$
		@ $\pm 1200 \text{ A}_{\max}$	0 7	Ω
	with $\pm 24 \text{ V}$	@ $\pm 1000 \text{ A}_{\max}$	0 50	Ω
	@ $\pm 2000 \text{ A}_{\max}$	0 7	Ω	
I_{SN}	Secondary nominal current rms	200	mA	
K_N	Conversion ratio	1 : 5000		
V_C	Supply voltage ($\pm 5 \%$)	$\pm 15 \dots 24$	V	
I_C	Current consumption	< 30 (@ $\pm 24 \text{ V}$) + I_S	mA	

Accuracy - Dynamic performance data

X_G	Overall accuracy @ I_{PN} , $T_A = 25^\circ\text{C}$	$< \pm 0.4$	%
		@ I_{PN} , $T_A = -40^\circ\text{C} \dots +85^\circ\text{C}$	$< \pm 1$
ε_L	Linearity error	< 0.1	%
		Max	
I_O	Offset current @ $I_P = 0$, $T_A = 25^\circ\text{C}$	± 0.5	mA
I_{OT}	Temperature variation of I_O - $40^\circ\text{C} \dots +85^\circ\text{C}$	± 1	mA
t_r	Response time ²⁾ to 90 % of I_{PN} step	< 1	μs
di/dt	di/dt accurately followed	> 100	A/ μs
BW	Frequency bandwidth (-1 dB)	DC .. 100	kHz

General data

T_A	Ambient operating temperature	$-40 \dots +85$	$^\circ\text{C}$
T_S	Ambient storage temperature	$-45 \dots +90$	$^\circ\text{C}$
R_S	Secondary coil resistance @ $T_A = 85^\circ\text{C}$	44	Ω
m	Mass	750	g
	Standards	EN 50155: 2001	

Features

- Closed loop (compensated) current transducer using the Hall effect
- Isolated plastic case recognized according to UL 94-V0.

Advantages

- Excellent accuracy
- Very good linearity
- Low temperature drift
- Optimized response time
- Wide frequency bandwidth
- No insertion losses
- High immunity to external interference
- Current overload capability.

Applications

- Single or three phase inverters
- Propulsion and braking chopper
- Propulsion converter
- Auxiliary converter
- Battery charger.

Application Domain

- Traction.

Notes: ¹⁾ With a di/dt of $> 5 \text{ A}/\mu\text{s}$

²⁾ With a di/dt of $100 \text{ A}/\mu\text{s}$.

Current Transducer LTC 1000-S

Isolation characteristics

V_d	Rms voltage for AC insulation test, 50 Hz, 1 min	13.4 ¹⁾	kV
		1.5 ²⁾	kV
V_e	Partial discharge extinction voltage rms	> 2.8 ³⁾	kV
		Min	
dCp	Creepage distance	66.7	mm
dCl	Clearance	45.9	mm
CTI	Comparative Tracking Index (group I)	600	

Notes: ¹⁾ Between primary and secondary + shield

²⁾ Between secondary and shield

³⁾ Test carried out with a busbar Ø 40 mm centred in the through-hole.

Safety



This transducer must be used in electric/electronic equipment with respect to applicable standards and safety requirements in accordance with the manufacturer's operating instructions.



Caution, risk of electrical shock

When operating the transducer, certain parts of the module can carry hazardous voltage (eg. primary busbar, power supply).

Ignoring this warning can lead to injury and/or cause serious damage.

This transducer is a build-in device, whose conducting parts must be inaccessible after installation.

A protective housing or additional shield could be used.

Main supply must be able to be disconnected.

Dimensions LTC 1000-S (in mm)

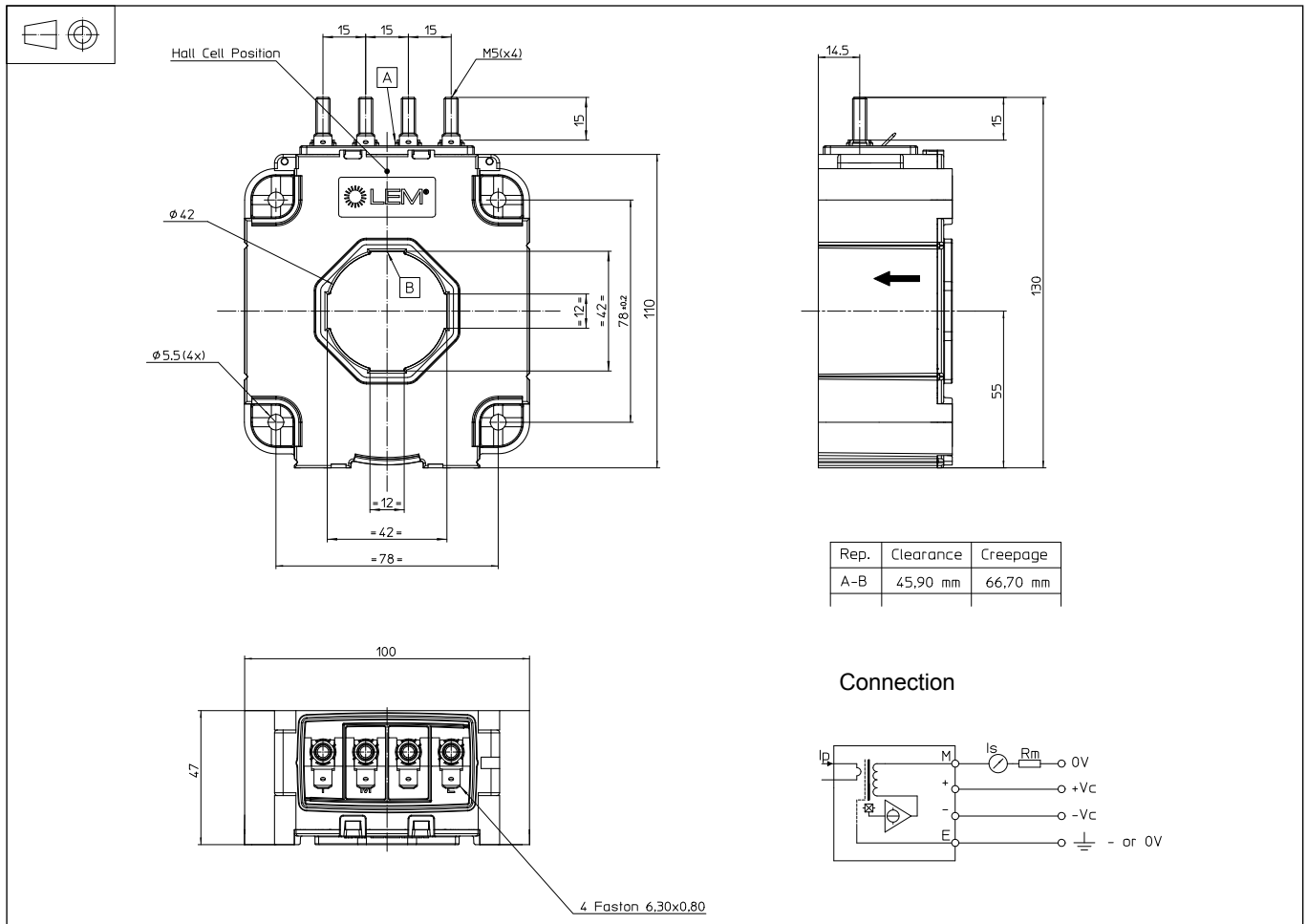

Mechanical characteristics

- General tolerance ± 1 mm
- Transducer fastening
 - 4 holes $\phi 5.5$ mm
 - 4 screws M5
 - Recommended fastening torque 4 Nm
- Primary through-hole $\phi 42$ mm
- Connection of secondary
 - 4 M5 threaded studs
 - Recommended fastening torque 2.2 Nm
 - Faston 6.3 x 0.8 mm

Remarks

- I_s is positive when I_p flows in the direction of the arrow.
- Temperature of the primary conductor should not exceed 100°C .
- Dynamic performances (di/dt and response time) are best with a single bar completely filling the primary hole.
- This is a standard model. For different versions (supply voltages, turns ratios, unidirectional measurements...), please contact us.

LTC 1000-S / Mechanical adaptation accessories

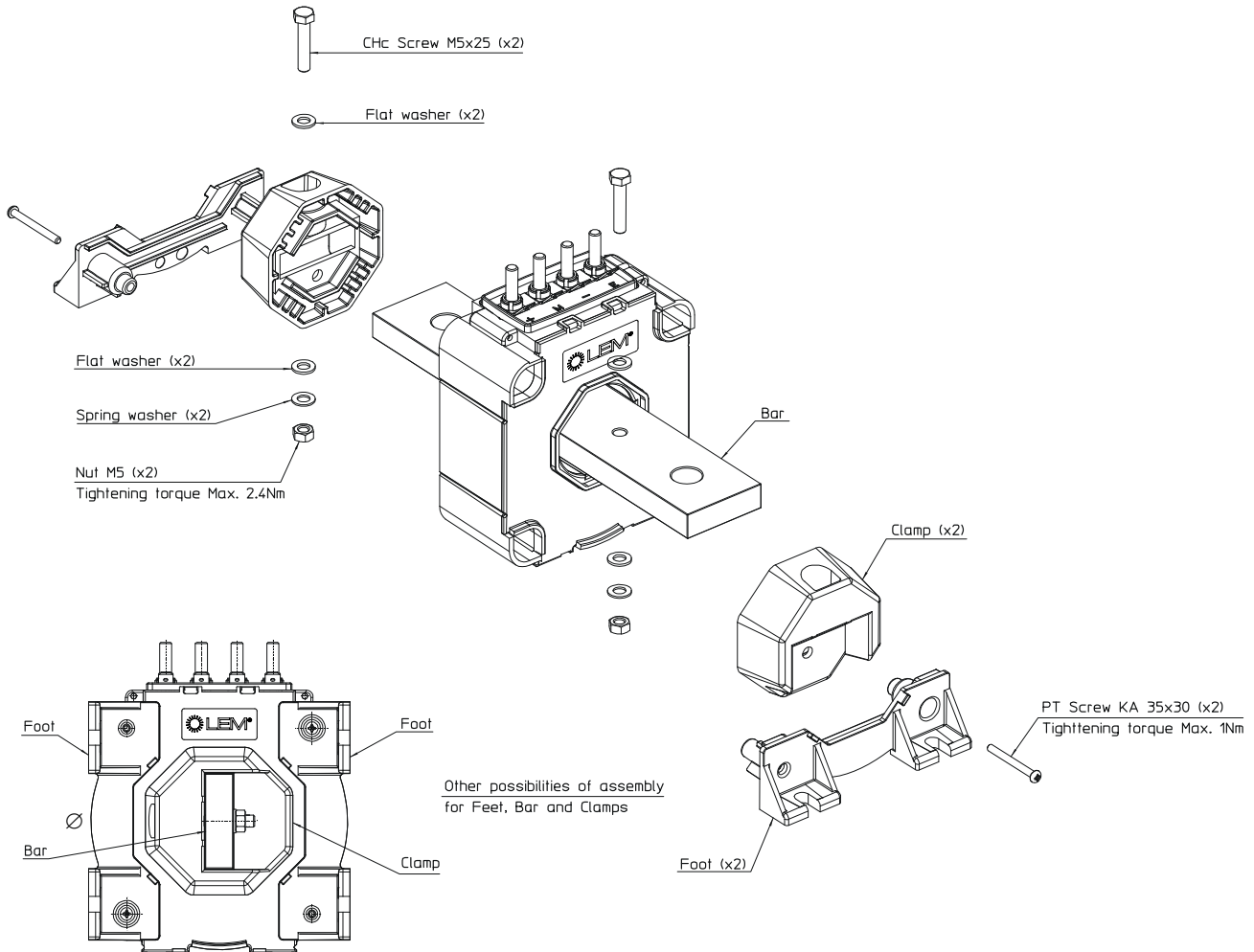

Lines	Accessories	References
1	Busbar KIT * (busbar : 210 x 40 x 12 mm)	93.34.61.100.0
2	Busbar KIT * (busbar : 185 x 40 x 8 mm)	93.34.61.102.0
3	Busbar KIT * (busbar : 285 x 36 x 12 mm)	93.34.61.103.0
4	Busbar KIT * (busbar : 260 x 36 x 12 mm)	93.34.61.104.0
5	Busbar KIT * (busbar : 195 x 36 x 10 mm)	93.34.61.105.0
6	Busbar KIT * (busbar : 36 mm Ø x 325 mm)	93.34.61.106.0
7	Busbar KIT * (busbar : 185 x 40 x 10 mm)	93.34.61.107.0
8	Busbar KIT * (busbar : 180 x 40 x 12 mm)	93.34.61.108.0
9	Busbar Fastening Kit (M5 x 25)** dedicated to busbars from lines 1 to 5 and lines 7, 8.	93.34.61.200.0
10	Busbar Fastening Kit (M5 x 40)** dedicated to busbar from line 6	93.34.61.201.0
11	Feet fixing Kit ***	93.34.63.100.0

* including all the necessary for its mounting such as screws, washers, nuts, 2 clamps, busbar.

** as with * but without the busbar.

*** including screws and 2 feet.



Rms voltage value for partial discharge extinction depends on the busbar. Refer to the datasheet of the corresponding product.