

SPECIFICATIONS SHEET FOR APPROVAL

MYLAR SPEAKER
P/N: MSI28-P15011

DESCRIPTION: D28mm, H5.0mm Mylar speaker, 0.5W, 480Hz, 8Ohm, Mylar cone, RoHS Compliance (Directive 2002/95/EC)

VERSION: 01

DATE: 5-Feb-15

REVISIONS

| VERSION | DESCRIPTION | DATE |
|---------|---------------------------|----------|
| 01 | Released from engineering | 5-Feb-15 |
| | | |
| | | |
| | | |
| | | |
| | | |

APPROVED BY :

CUSTOMER NAME :

DATE :

SPECIFICATIONS SHEET

MYLAR SPEAKER
 P/N: MSI28-P15011

1. SPECIFICATIONS

| PARAMETERS | VALUES | UNITS |
|-----------------------------------|--------------|-------|
| *SOUND PRESSURE LEVEL | 90 ± 3 | dBA |
| RESONANCE FREQUENCY | 480 ± 20% | Hz |
| FREQUENCY RANGE | Fo – 20,000 | Hz |
| RATED IMPEDANCE | 8 ± 15% | Ohm |
| RATED POWER | 0,5 | W |
| MAX POWER | 1.0 | W |
| OPERATING TEMPERATURE | -20 to +60 | °C |
| STORAGE TEMPERATURE | -30 to +60 | °C |
| DISTORTION AT 1KHZ AT RATED POWER | <5% | - |
| MAGNET | Φ9.5*1mm N35 | - |
| DIAPHRAGM MATERIAL | MYLAR | - |
| FRAME MATERIAL | METAL | - |
| WEIGHT | 5.2 | g |

*Tested at 0.5W 0.1m average 0.6K 0.8K 1.0K 1.2K Hz

2. DIMENSIONS (unit in mm)

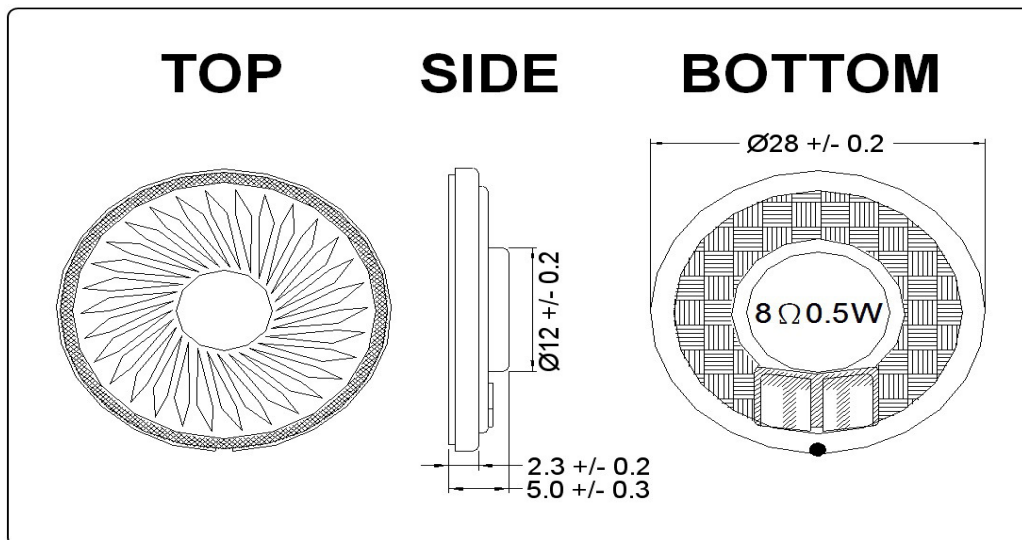

Tolerance: ±0.5mm except specified

VERSION: 01

DATE: 5-Feb-15

All specifications subject to change without notice

3. FREQUENCY RESPONSE CURVE

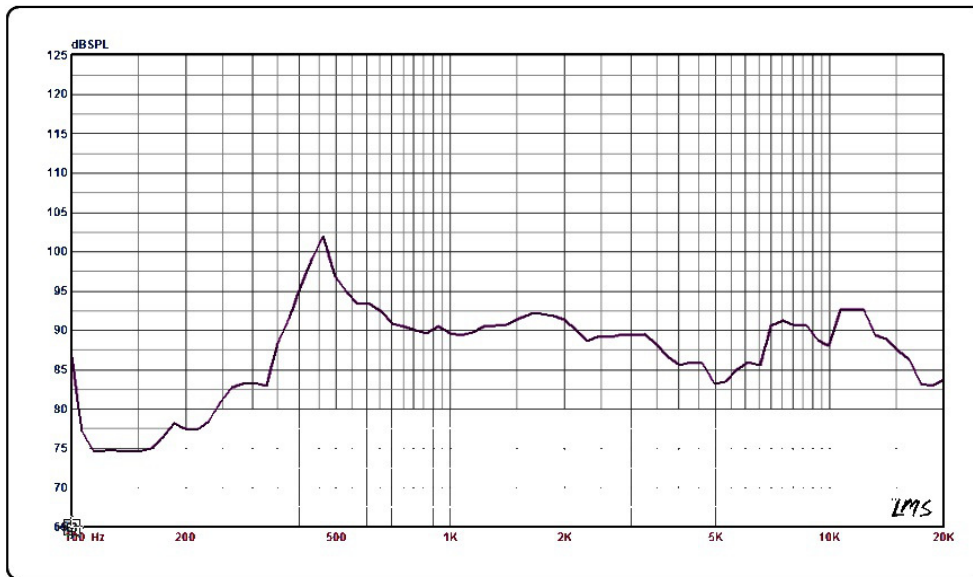

4. MEASURING CONDITION

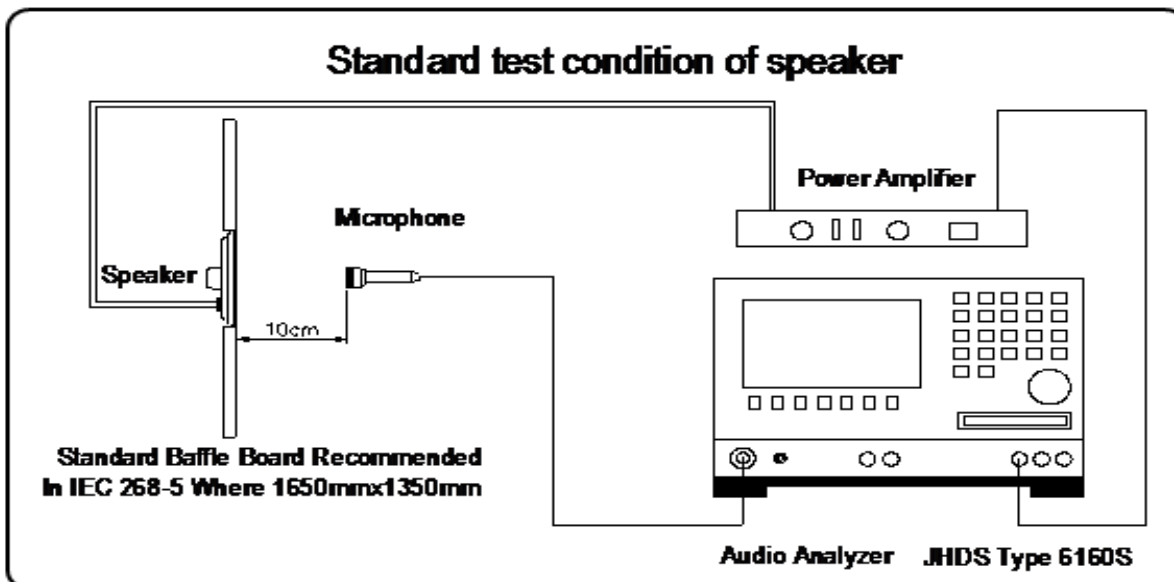

VERSION: 01
 DATE: 5-Feb-15

All specifications subject to change without notice