

TDK RF Products for Wireless LAN

2004/3/5

for 2.4GHz

Antennas

Start Freq. MHz	Stop Freq. MHz	Type	Gain dBi(MAX)	Return loss dB (MAX)	Size mm (typ.)	Part No.
2400	2485	SMD ceramic patch	-3	-2	7.0x7.0x1.5	CABPB0715A
2400	2500	SMD ceramic patch	-1	-2.5	7.0x7.0x3.0	CABPB0730A
2400	2500	SMD ceramic patch	+2	-6	12.0x12.0x4.0	CABPB1240A
2400	2500	SMD ceramic multilayer	+1	-15	8.0x3.0x1.2	ANT8030-2R4-01

Sample Available
Under Developing

CERAMIC PATCH ANTENNA FOR Bluetooth & 2.4 GHz W-LAN
SAMPLE P/N: CABPB0715A (7x7x1.5 mm type)

[MECHANICAL DIMENSIONS]

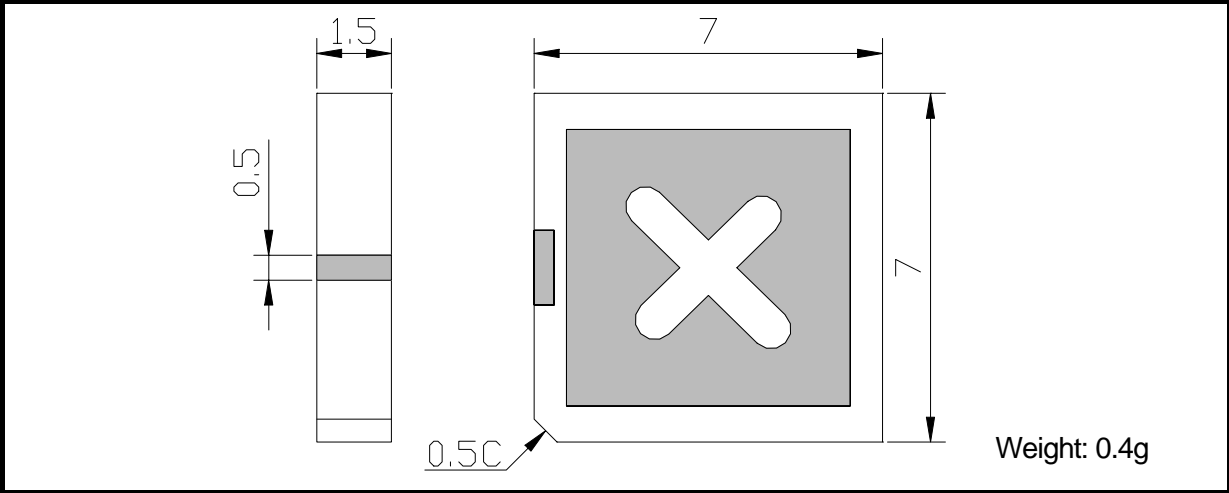

[ELECTRICAL CHARACTERISTICS]

PARAMETER	FREQ (MHz)	MIN.	MAX.	UNIT
Centre frequency		2442		MHz
Bandwidth		85		MHz
Antenna Gain	2400-2485		-3	dBi
Impedance	2400-2485	50		ohm
Return Loss	2400-2485		-2	dB
VSWR	2400-2485		8.5	

Operating temperature	-30	+85	°C
Storage temperature	-40	+85	°C

Note: Please use the 0dBi = -2.15dBd to convert antenna gain expressed in dBd.

[RECOMMENDED PCB PATTERN]

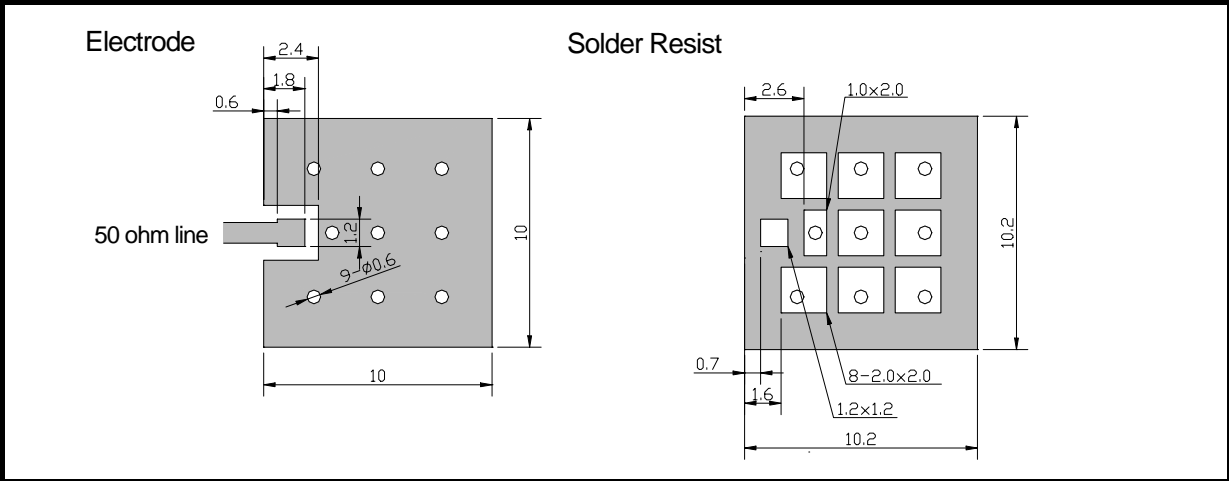

*Note: This document is PRELIMINARY. All specifications are subject to change without notice and are not guaranteed.

[RADIATION PATTERN]

- Item: CABPB0715A (7x7x1.5mm Type)
- Standard antenna: Standard dipole (Anritsu)
- Tx antenna: Horn (TECOM)

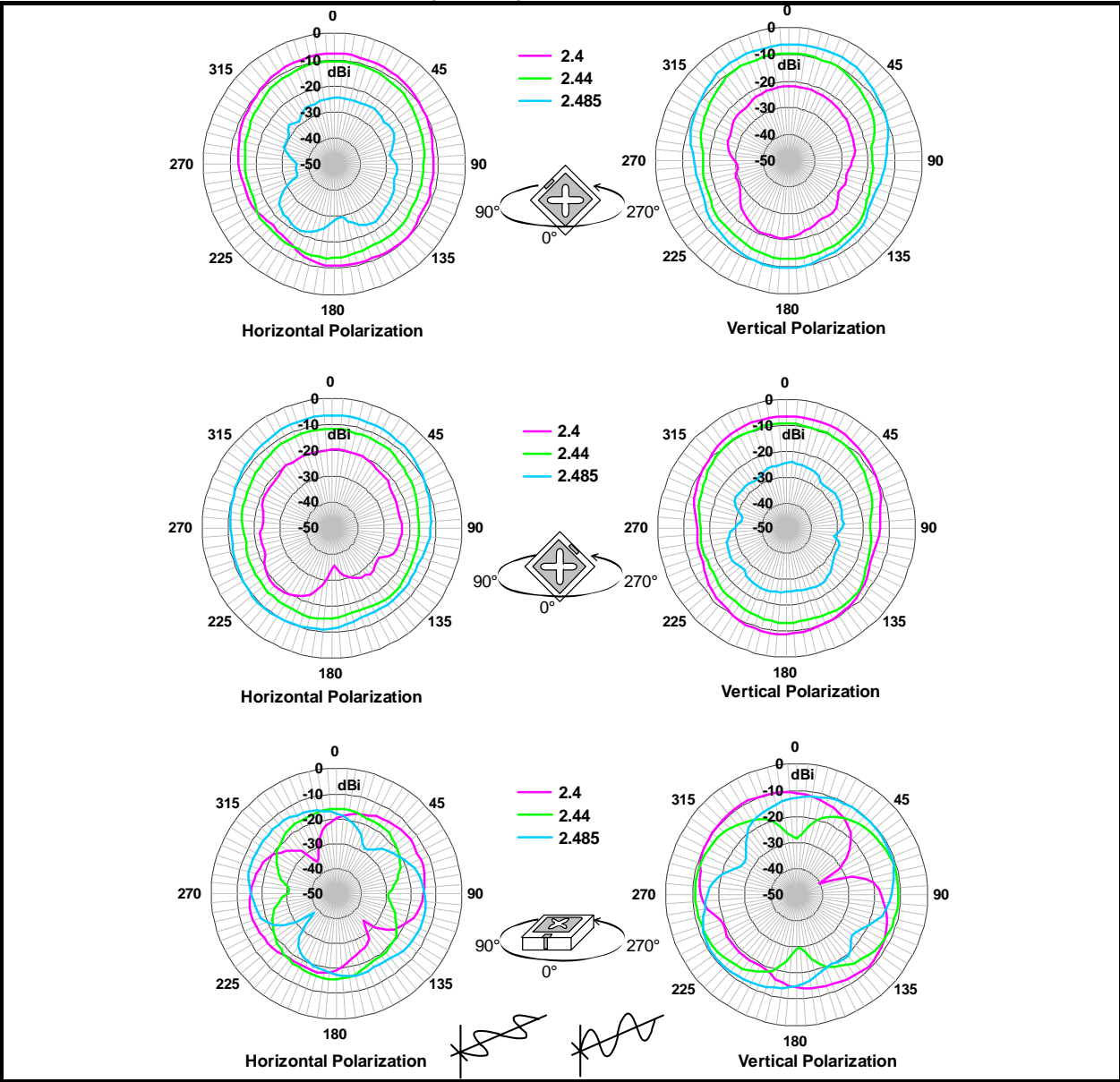

Note: Tested antenna has been soldered on 30x30 mm² PCB.

[RETURN LOSS&GAIN]

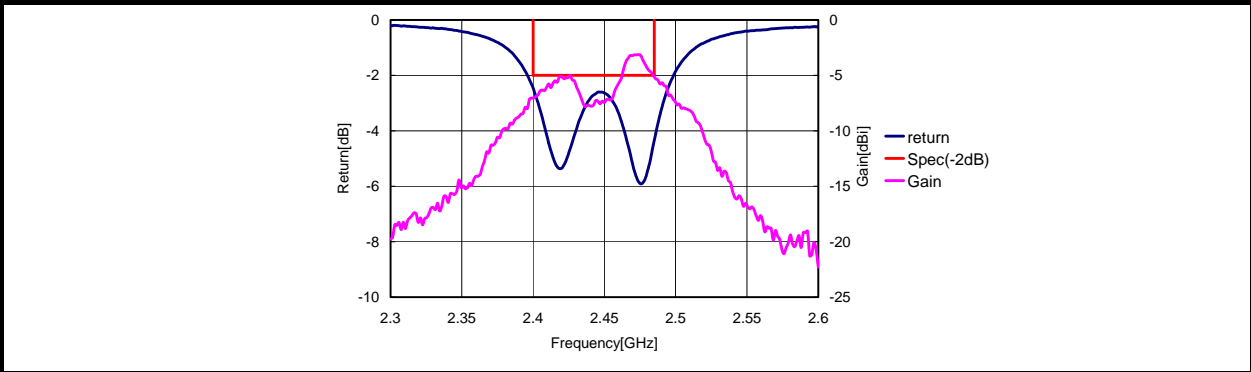

Note: Tested antenna has been soldered on 30x30 mm² PCB.

*Note: This document is PRELIMINARY. All specifications are subject to change without notice and are not guaranteed.

CERAMIC PATCH ANTENNA FOR Bluetooth & 2.4GHz W-LAN

SAMPLE P/N: CABPB0730A (7x7x3 mm type)

[MECHANICAL DIMENSIONS]

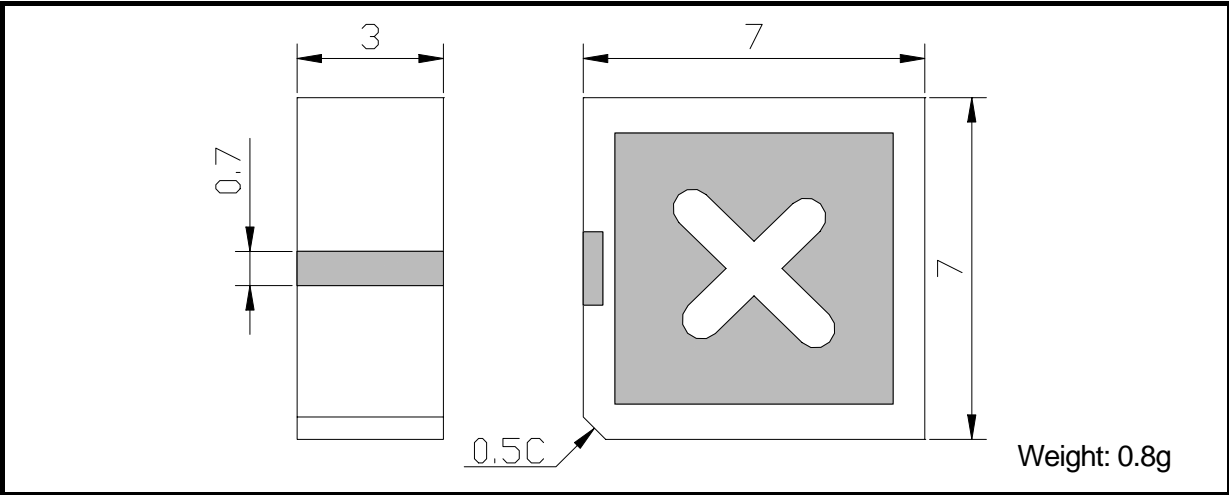

[ELECTRICAL CHARACTERISTICS]

PARAMETER	FREQ (MHz)	MIN.	MAX.	UNIT
Centre frequency		2442		MHz
Bandwidth		85		MHz
Antenna Gain	2400-2485		-1	dBi
Impedance	2400-2485	50		ohm
Return Loss	2400-2485		-2.5	dB
VSWR	2400-2485		7	

Operating temperature	-30	+85	°C
Storage temperature	-40	+85	°C

Note: Please use the 0dBi = -2.15dBd to convert antenna gain expressed in dBd.

[RECOMMENDED PCB PATTERN]

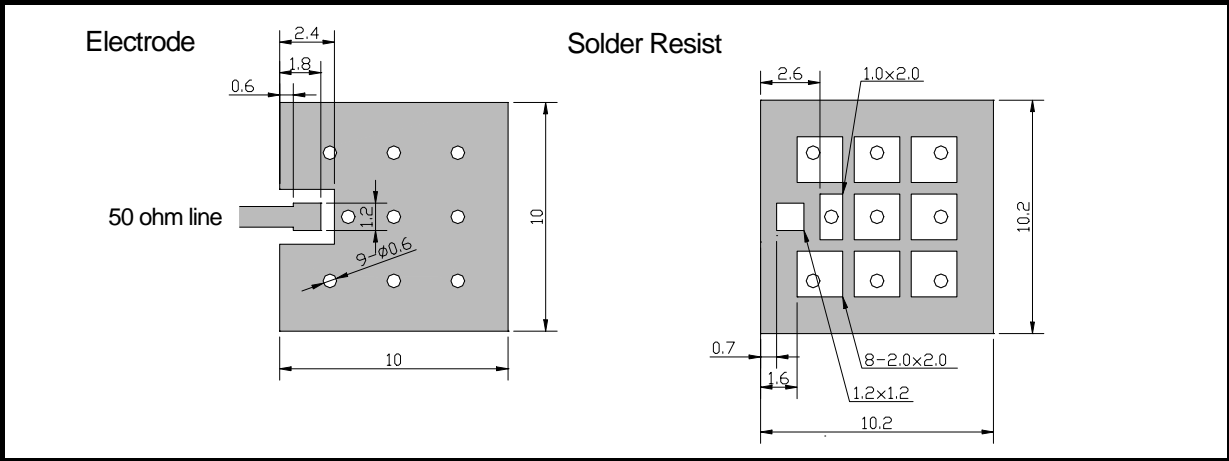

*Note: This document is PRELIMINARY. All specifications are subject to change without notice and are not guaranteed.

[RADIATION PATTERN]

- Item: CABPB0730A (7x7x3mm Type)
- Standard antenna: Standard dipole (Anritsu)
- Tx antenna: Horn (TECOM)

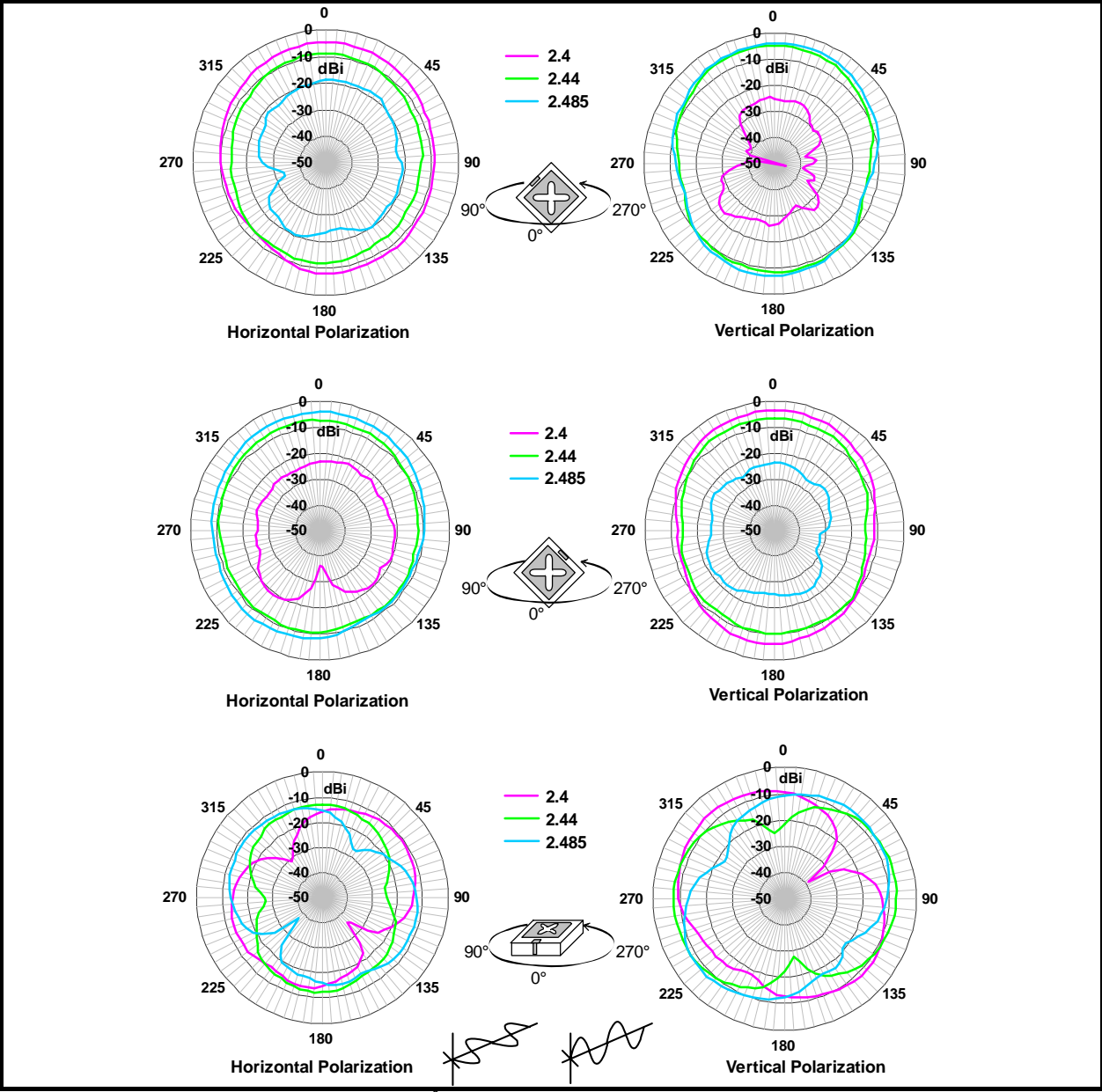

Note: Tested antenna has been soldered on 30x30 mm² PCB.

[RETURN LOSS&GAIN]

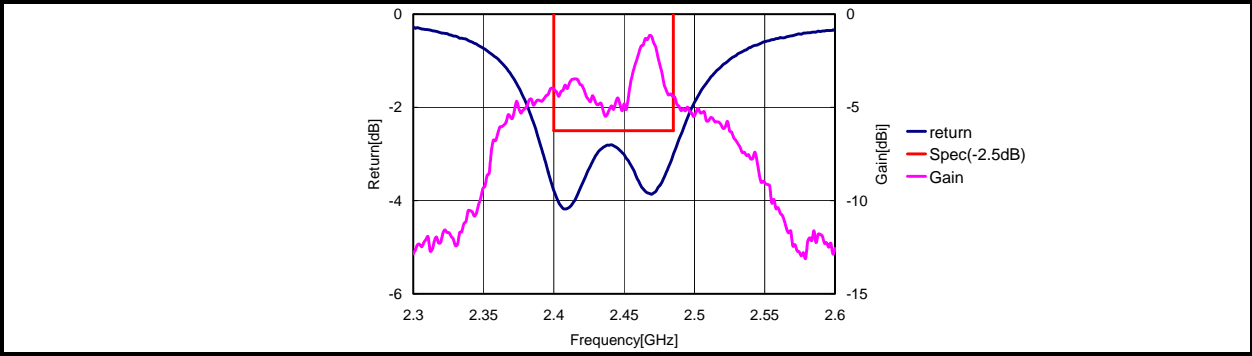

Note: Tested antenna has been soldered on 30x30 mm² PCB.

*Note: This document is PRELIMINARY. All specifications are subject to change without notice and are not guaranteed.

CERAMIC PATCH ANTENNA FOR Bluetooth & 2.4GHz W-LAN
SAMPLE P/N: CABPB1240A (12x12x4 mm type)

[MECHANICAL DIMENSIONS]

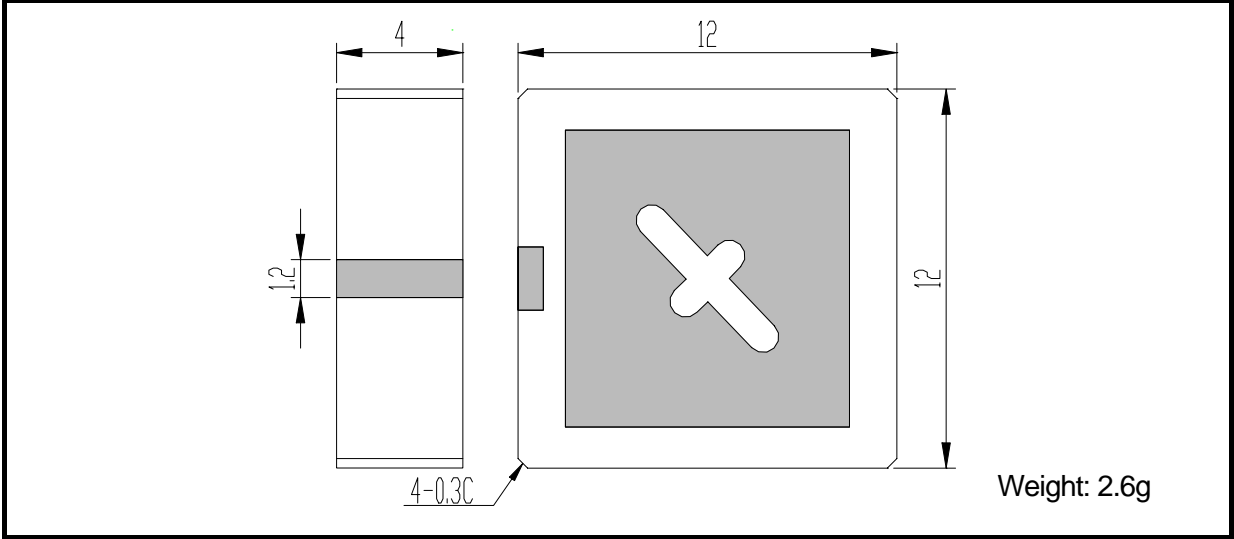

[ELECTRICAL CHARACTERISTICS]

PARAMETER	FREQ (MHz)	MIN.	MAX.	UNIT
Center frequency		2442		MHz
Bandwidth		85		MHz
Antenna Gain	2400-2485		+2	dBi
Impedance	2400-2485	50		ohm
Return Loss	2400-2485		-6	dB
VSWR	2400-2485		3	

Operating temperature	-30	+85	°C
Storage temperature	-40	+85	°C

Note: Please use the 0 dBi = -2.15dBd to convert antenna gain expressed in dBd.

[RECOMMENDED PCB PATTERN]

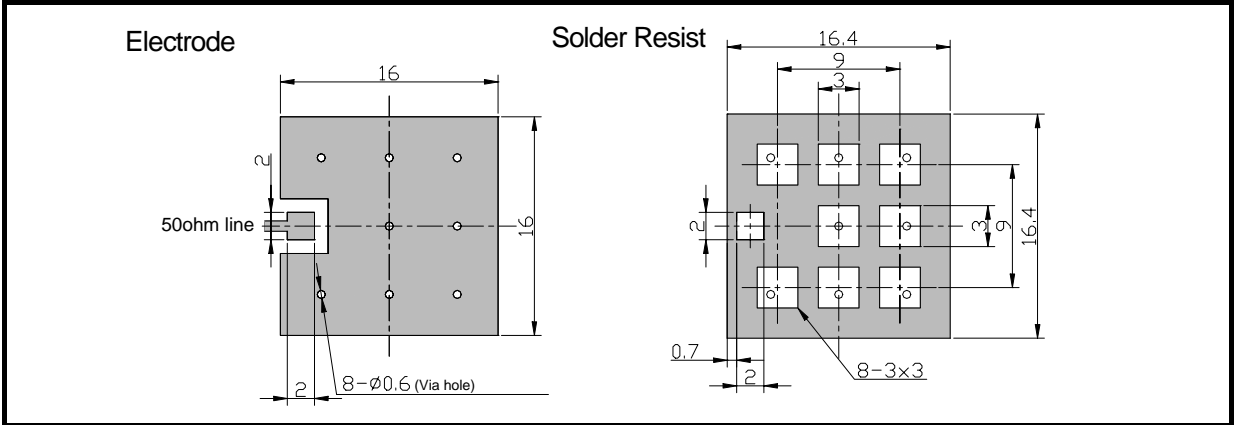

*Note: This document is PRELIMINARY. All specifications are subject to change without notice and are not guaranteed.

[RADIATION PATTERN]

- Item: CABPB1240A (12x12x4mm Type)
- Standard antenna: Standard dipole (Anritsu)
- Tx antenna: Horn (Condor Systems)

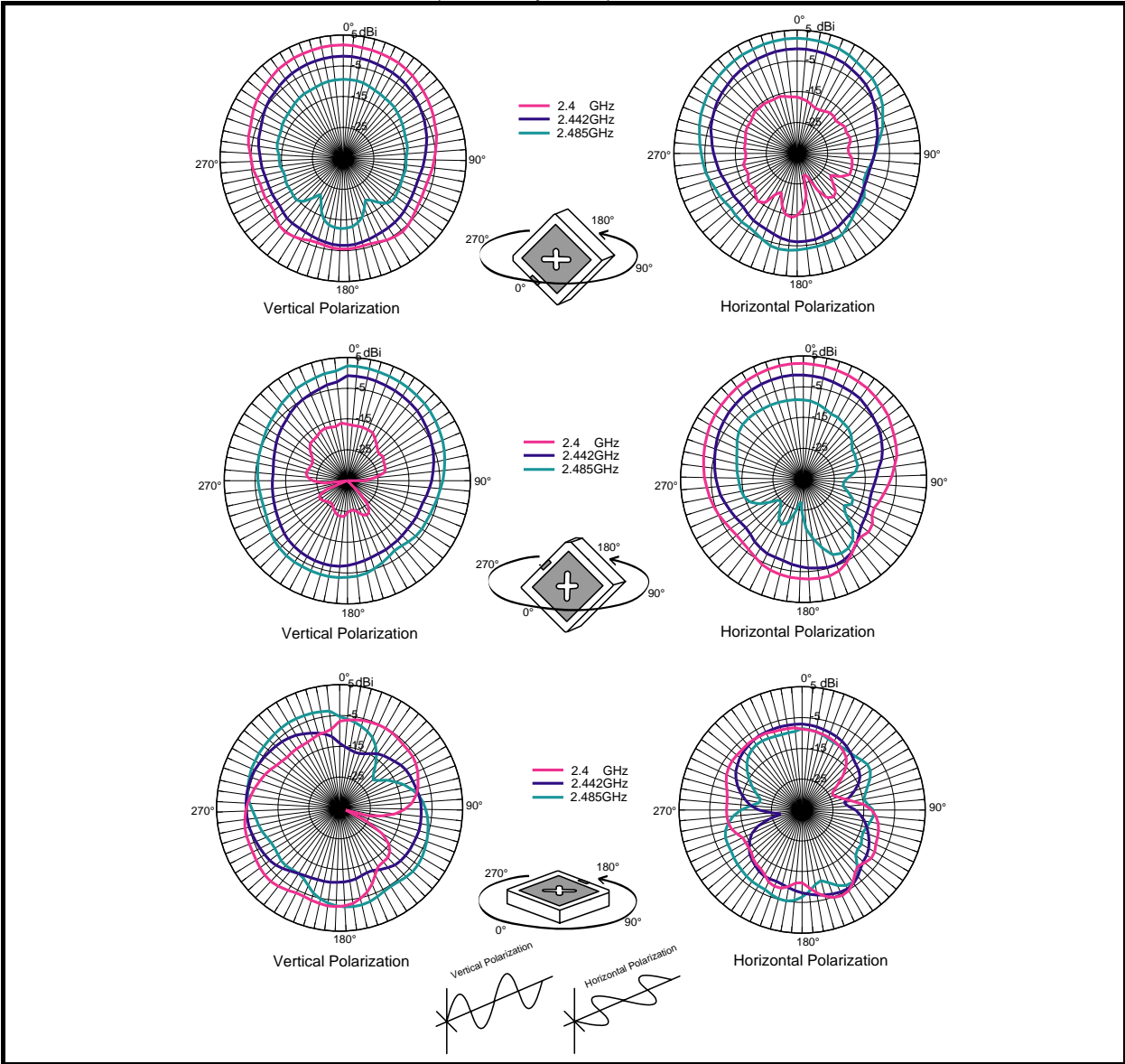

Note: Tested antenna has been soldered on 40x40 mm² PCB.

[RETURN LOSS&GAIN]

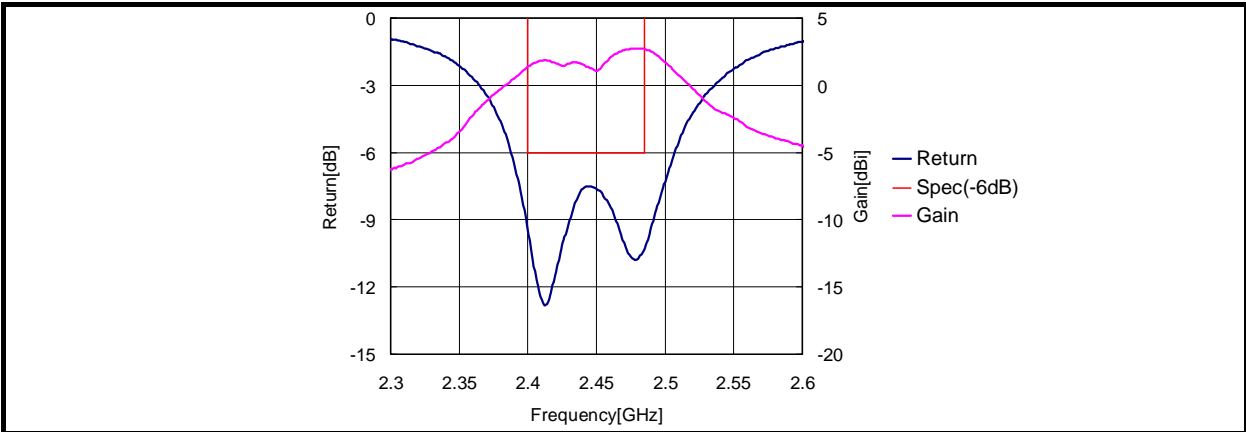

*Note: This document is PRELIMINARY. All specifications are subject to change without notice and are not guaranteed.

CHIP MULTILAYER ANTENNA FOR 2.4 GHz W-LAN / Bluetooth

SAMPLE P/N: **ANT8030-2R4-01**□*

* □ is center frequency variation code (A to E).

[MECHANICAL DIMENSIONS]

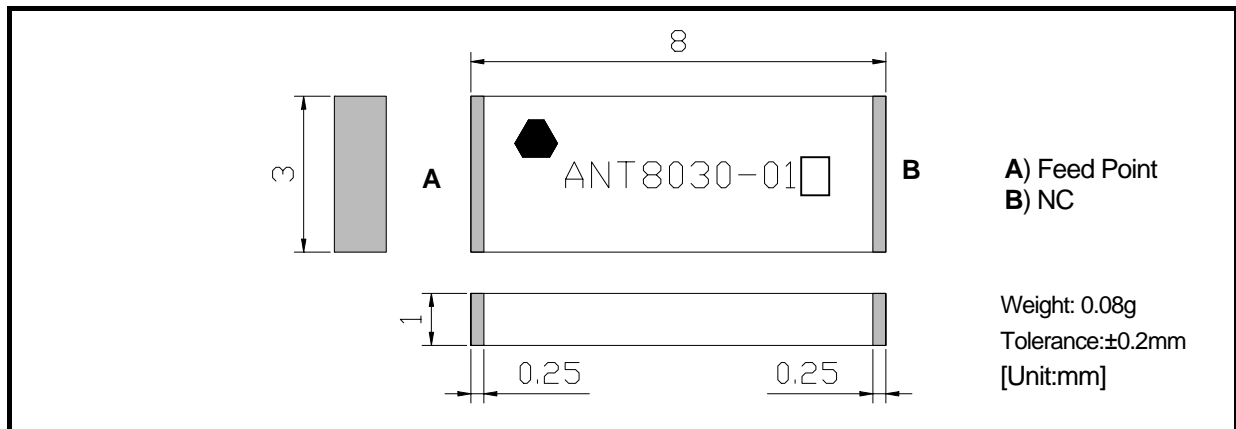

[ELECTRICAL CHARACTERISTICS]

Product name	ANT8030 -2R4-01A	ANT8030 -2R4-01B	ANT8030 -2R4-01C	ANT8030 -2R4-01D	ANT8030 -2R4-01E
Center frequency	2450 MHz	2500 MHz	2550 MHz	2600 MHz	2650 MHz
Bandwidth	100 MHz				
Polarization	Linear				
Antenna Gain	2 dBi (Max)				
Impedance	50 ohm				
VSWR	2 (Max)				

Operating temperature	-30	+85	°C
Storage temperature	-40	+85	°C

Note: Please use the $0\text{dBi} = -2.15\text{dBd}$ to convert antenna gain expressed in dBd.

[RECOMMENDED PCB PATTERN]

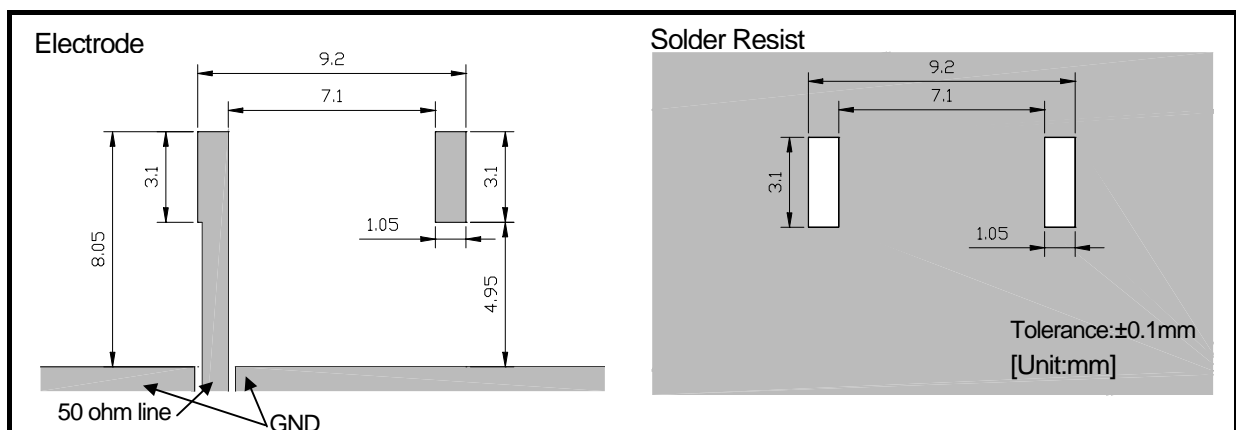

Note: This document is PRELIMINARY. All specifications are subject to change without notice and are not guaranteed.

- Item: ANT8030-2R4-01A
- Standard antenna: Standard dipole (Anritsu)
- Tx antenna: Horn (TECOM)

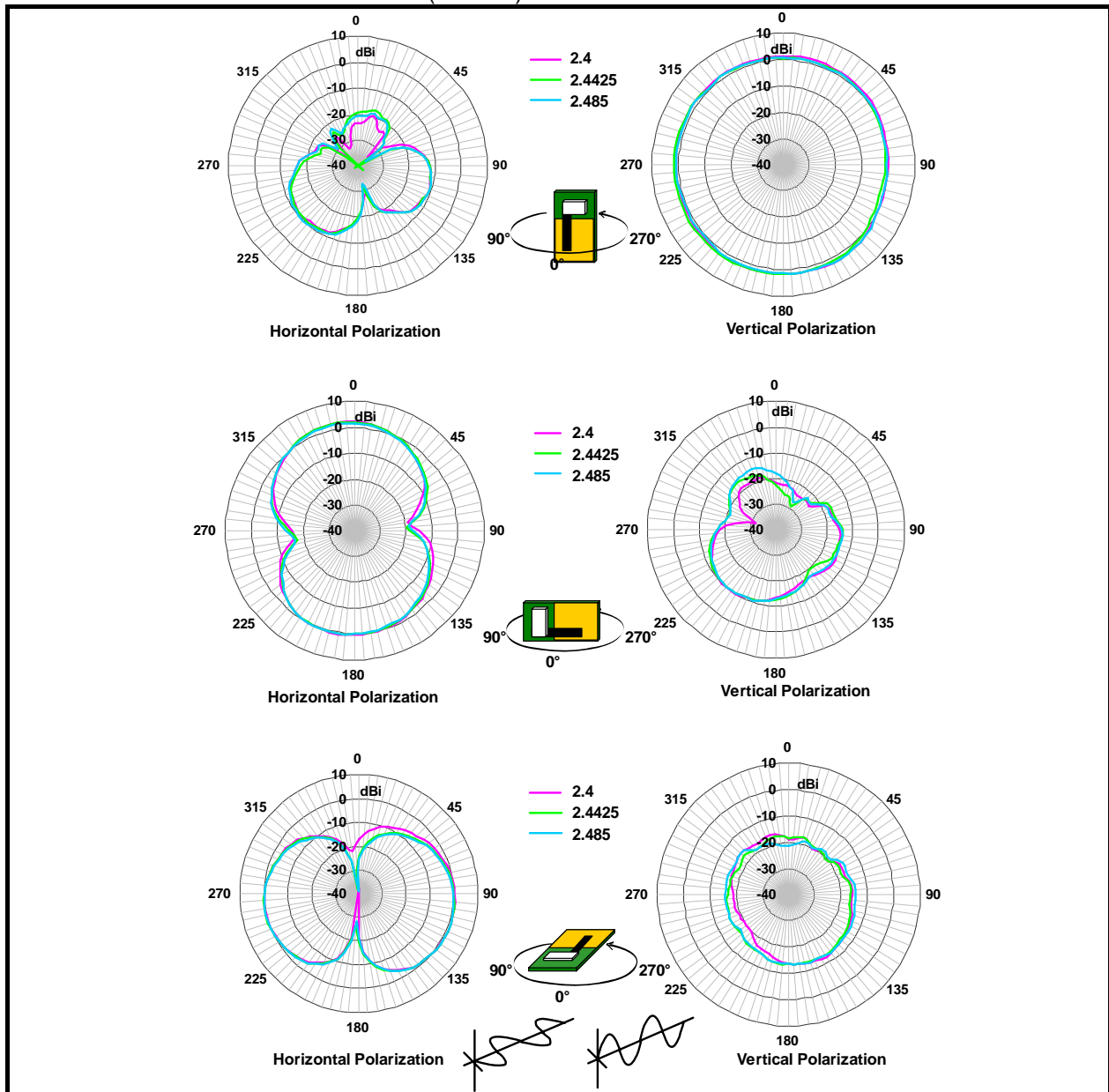

Note: Tested antenna has been soldered on 55x20 mm² PCB.

[V.S.W.R.]

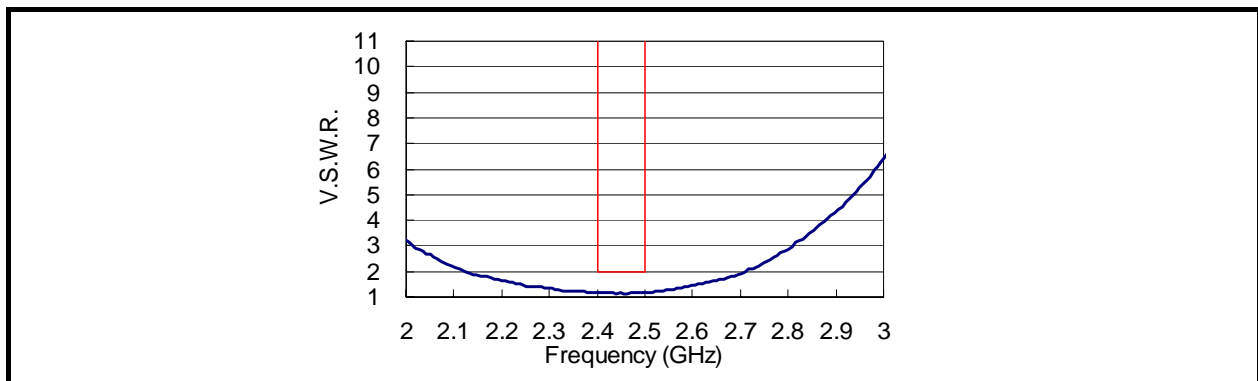

Note: Tested antenna has been soldered on 55x20 mm² PCB.

Note: This document is PRELIMINARY. All specifications are subject to change without notice and are not guaranteed.