

Low Power Consumption LDO

Features

- Ultra low quiescent current: 4 μ A (typ.)
- High input voltage (up to 12V)
- Output voltage:
1.8V, 2.5V, 2.7V, 3.0V, 3.3V, 3.5V, 5.0V
- Output voltage accuracy: tolerance \pm 3%
- Maximum output current: 250mA
- Low dropout voltage
- Low temperature coefficient
- TO 92, SOT 89 package

Applications

- Battery powered equipment
- Voltage regulator for microprocessor
- Voltage regulator for LAN cards
- Wireless Communication equipment
- Audio/Video equipment

General Description

The HT73XX series is a set of three terminal, low power, high voltage regulators implemented in CMOS technology. The series features extremely low quiescent current which is typically 4 μ A. They allow input voltages as high as 12V. The device provides large current with a significantly small dropout voltage.

The HT73XX consists of a high precision voltage reference, an error correction circuit, and a current limited output driver. They are available with several fixed output voltages ranging from 1.8V to 5.0V. CMOS technology ensures low dropout voltage and low current consumption. Although designed primarily as fixed voltage regulators, these devices can be used with external components to generate variable voltages and currents.

Selection Table

Part No.	Output Voltage	Tolerance	Package	Marking
HT7318	1.8V	\pm 3%	TO 92 A TO 92 B SOT 89 A	73XX A (for TO 92 A) 73XX B (for TO 92 B) 73XX A (for SOT 89)
HT7325	2.5V	\pm 3%		
HT7327	2.7V	\pm 3%		
HT7330	3.0V	\pm 3%		
HT7333	3.3V	\pm 3%		
HT7335	3.5V	\pm 3%		
HT7350	5.0V	\pm 3%		

Note: "XX" stands for output voltages

Block Diagram

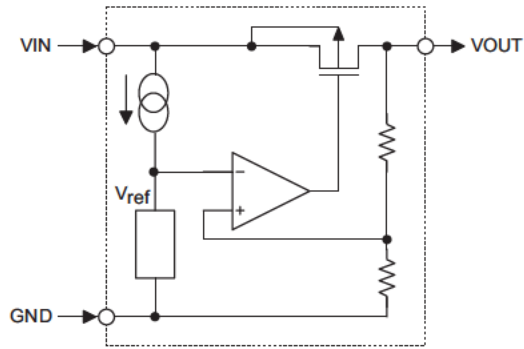

Pin Assignment

TO-92-A

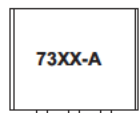

Front View

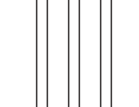

GND VIN VOUT

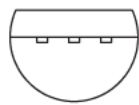

Bottom View

TO-92-B

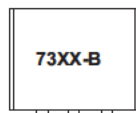

Front View

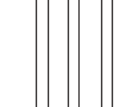

VIN GND VOUT

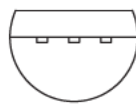

Bottom View

SOT-89-A

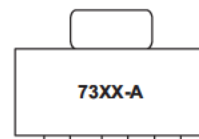

GND VIN VOUT

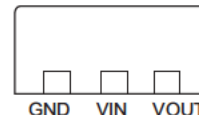

GND VIN VOUT

Absolute Maximum Ratings

Supply Voltage	$V_{SS}-0.3V$ to $V_{SS}+14V$	Storage Temperature	$-50^{\circ}C$ to $125^{\circ}C$
Power Consumption (*1)	500mW	Operating Temperature	$-40^{\circ}C$ to $85^{\circ}C$
Power Consumption (*2)	500mW		

Note: These are stress ratings only. Stresses exceeding the range specified under "Absolute Maximum Ratings" may cause substantial damage to the device. Functional operation of this device at other conditions beyond those listed in the specification is not implied and prolonged exposure to extreme conditions may affect device reliability.

*1: applied to TO 92
 *2: applied to SOT 89

Electrical Characteristics
HT7318, +1.8V Output Type

Ta=25°C

Symbol	Parameter	Test Conditions		Min.	Typ.	Max.	Unit
		V _{IN}	Conditions				
V _{OUT}	Output Voltage	2.8V	I _{OUT} =40mA	1.746	1.8	1.854	V
I _{OUT(MAX)}	Maximum Output Current	2.8V	V _{OUT} ≥1.62V	150	—	—	mA
ΔV _{OUT} *	Load Regulation	2.8V	1mA≤I _{OUT} ≤60mA	—	45	90	mV
V _{DROP**}	Dropout Voltage	—	I _{OUT} =40mA	—	170	—	mV
I _{SS}	Quiescent Current	2.8V	No load	—	4	8	μA
$\frac{\Delta V_{OUT}}{\Delta V_{IN} \times V_{OUT}}$	Line Regulation	—	I _{OUT} =40mA 2.8V≤V _{IN} ≤12V	—	0.2	0.3	%/V
V _{IN}	Input Voltage	—	—	—	—	12	V
$\frac{\Delta V_{OUT}}{\Delta T_a}$	Temperature Coefficient	2.8V	I _{OUT} =40mA -40°C<T _a <85°C	—	±0.7	—	ppm/°C

HT7325, +2.5V Output Type

Ta=25°C

Symbol	Parameter	Test Conditions		Min.	Typ.	Max.	Unit
		V _{IN}	Conditions				
V _{OUT}	Output Voltage	3.5V	I _{OUT} =40mA	2.425	2.5	2.575	V
I _{OUT(MAX)}	Maximum Output Current	3.5V	V _{OUT} ≥2.25V	180	—	—	mA
ΔV _{OUT} *	Load Regulation	3.5V	1mA≤I _{OUT} ≤60mA	—	45	90	mV
V _{DROP**}	Dropout Voltage	—	I _{OUT} =40mA	—	110	—	mV
I _{SS}	Quiescent Current	3.5V	No load	—	4	8	μA
$\frac{\Delta V_{OUT}}{\Delta V_{IN} \times V_{OUT}}$	Line Regulation	—	I _{OUT} =40mA 3.5V≤V _{IN} ≤12V	—	0.2	0.3	%/V
V _{IN}	Input Voltage	—	—	—	—	12	V
$\frac{\Delta V_{OUT}}{\Delta T_a}$	Temperature Coefficient	3.5V	I _{OUT} =40mA -40°C<T _a <85°C	—	±0.7	—	ppm/°C

HT7327, +2.7V Output Type

Ta=25°C

Symbol	Parameter	Test Conditions		Min.	Typ.	Max.	Unit
		V _{IN}	Conditions				
V _{OUT}	Output Voltage	3.7V	I _{OUT} =40mA	2.619	2.7	2.781	V
I _{OUT(MAX)}	Maximum Output Current	3.7V	V _{OUT} ≥2.43V	200	—	—	mA
ΔV _{OUT} *	Load Regulation	3.7V	1mA≤I _{OUT} ≤80mA	—	45	90	mV
V _{DROP**}	Dropout Voltage	—	I _{OUT} =40mA	—	100	—	mV
I _{SS}	Quiescent Current	3.7V	No load	—	4	8	μA
$\frac{\Delta V_{OUT}}{\Delta V_{IN} \times V_{OUT}}$	Line Regulation	—	I _{OUT} =40mA 3.7V≤V _{IN} ≤12V	—	0.2	0.3	%/V
V _{IN}	Input Voltage	—	—	—	—	12	V
$\frac{\Delta V_{OUT}}{\Delta T_a}$	Temperature Coefficient	3.7V	I _{OUT} =40mA -40°C<T _a <85°C	—	±0.7	—	ppm/°C

HT7330, +3.0V Output Type

Ta=25°C

Symbol	Parameter	Test Conditions		Min.	Typ.	Max.	Unit
		V _{IN}	Conditions				
V _{OUT}	Output Voltage	4V	I _{OUT} =40mA	2.91	3	3.09	V
I _{OUT(MAX)}	Maximum Output Current	4V	V _{OUT} ≥2.7V	250	—	—	mA
ΔV _{OUT} *	Load Regulation	4V	1mA≤I _{OUT} ≤80mA	—	45	90	mV
V _{DROP} **	Dropout Voltage	—	I _{OUT} =40mA	—	95	—	mV
I _{SS}	Quiescent Current	4V	No load	—	4	8	μA
$\frac{\Delta V_{OUT}}{\Delta V_{IN} \times V_{OUT}}$	Line Regulation	—	I _{OUT} =40mA 4V≤V _{IN} ≤12V	—	0.2	0.3	%/V
V _{IN}	Input Voltage	—	—	—	—	12	V
$\frac{\Delta V_{OUT}}{\Delta T_a}$	Temperature Coefficient	4V	I _{OUT} =40mA -40°C<T _a <85°C	—	±0.7	—	ppm/°C

HT7333, +3.3V Output Type

Ta=25°C

Symbol	Parameter	Test Conditions		Min.	Typ.	Max.	Unit
		V _{IN}	Conditions				
V _{OUT}	Output Voltage	4.3V	I _{OUT} =40mA	3.201	3.3	3.399	V
I _{OUT(MAX)}	Maximum Output Current	4.3V	V _{OUT} ≥2.97V	250	—	—	mA
ΔV _{OUT} *	Load Regulation	4.3V	1mA≤I _{OUT} ≤80mA	—	45	90	mV
V _{DROP} **	Dropout Voltage	—	I _{OUT} =40mA	—	90	—	mV
I _{SS}	Quiescent Current	4.3V	No load	—	4	8	μA
$\frac{\Delta V_{OUT}}{\Delta V_{IN} \times V_{OUT}}$	Line Regulation	—	I _{OUT} =40mA 4.3V≤V _{IN} ≤12V	—	0.2	0.3	%/V
V _{IN}	Input Voltage	—	—	—	—	12	V
$\frac{\Delta V_{OUT}}{\Delta T_a}$	Temperature Coefficient	4.3V	I _{OUT} =40mA -40°C<T _a <85°C	—	±0.7	—	ppm/°C

HT7335, +3.5V Output Type

Ta=25°C

Symbol	Parameter	Test Conditions		Min.	Typ.	Max.	Unit
		V _{IN}	Conditions				
V _{OUT}	Output Voltage	4.5V	I _{OUT} =40mA	3.395	3.5	3.605	V
I _{OUT(MAX)}	Maximum Output Current	4.5V	V _{OUT} ≥3.15V	250	—	—	mA
ΔV _{OUT} *	Load Regulation	4.5V	1mA≤I _{OUT} ≤80mA	—	45	90	mV
V _{DROP} **	Dropout Voltage	—	I _{OUT} =40mA	—	80	—	mV
I _{SS}	Quiescent Current	4.5V	No load	—	4	8	μA
$\frac{\Delta V_{OUT}}{\Delta V_{IN} \times V_{OUT}}$	Line Regulation	—	I _{OUT} =40mA 4.5V≤V _{IN} ≤12V	—	0.2	0.3	%/V
V _{IN}	Input Voltage	—	—	—	—	12	V
$\frac{\Delta V_{OUT}}{\Delta T_a}$	Temperature Coefficient	4.5V	I _{OUT} =80mA -40°C<T _a <85°C	—	±0.7	—	ppm/°C

HT7350, +5.0V Output Type

Ta=25°C

Symbol	Parameter	Test Conditions		Min.	Typ.	Max.	Unit
		V _{IN}	Conditions				
V _{OUT}	Output Voltage	6V	I _{OUT} =40mA	4.85	5	5.15	V
I _{OUT(MAX)}	Maximum Output Current	6V	V _{OUT} ≥4.5V	250	—	—	mA
ΔV _{OUT} *	Load Regulation	6V	1mA≤I _{OUT} ≤100mA	—	45	90	mV
V _{DROP} **	Dropout Voltage	—	I _{OUT} =40mA	—	60	—	mV
I _{SS}	Quiescent Current	6V	No load	—	4	8	μA
$\frac{\Delta V_{OUT}}{\Delta V_{IN} \times V_{OUT}}$	Line Regulation	—	I _{OUT} =40mA 6V≤V _{IN} ≤12V	—	0.2	0.3	%/V
V _{IN}	Input Voltage	—	—	—	—	12	V
$\frac{\Delta V_{OUT}}{\Delta T_a}$	Temperature Coefficient	6V	I _{OUT} =80mA -40°C<T _a <85°C	—	±0.7	—	ppm/°C

Note: *** Regulation is measured at constant junction temperature, using pulsed ON time.

**** Dropout is measured at constant junction temperature, using pulsed ON time, and the criterion is V_{OUT} in side target value ±2%.

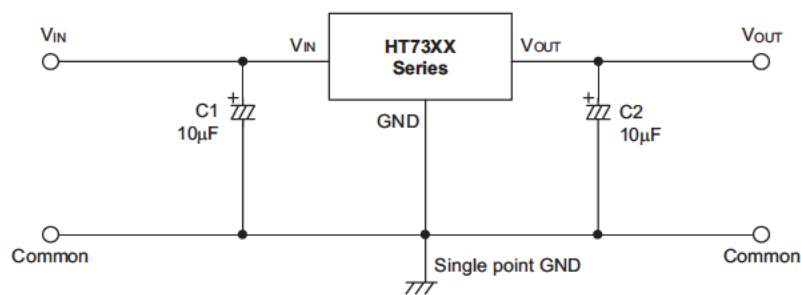
Application Circuits

Package Information

3-pin TO-92 Outline Dimensions

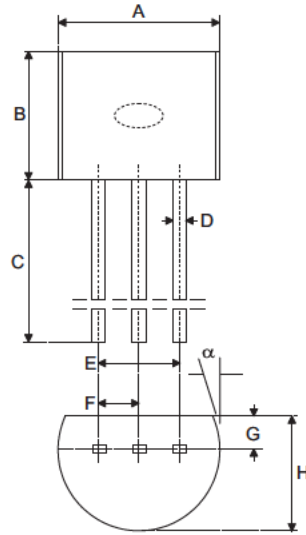

Symbol	Dimensions in mil		
	Min.	Nom.	Max.
A	170	—	200
B	170	—	200
C	500	—	—
D	11	—	20
E	90	—	110
F	45	—	55
G	45	—	65
H	130	—	160
I	8	—	18
α	4°	—	6°

3-pin SOT-89 Outline Dimensions

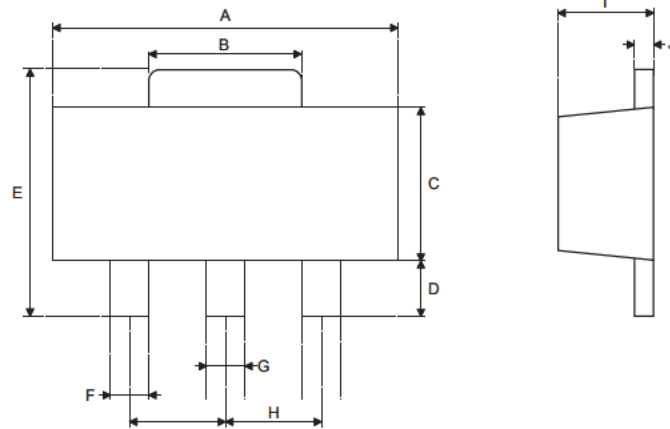

Symbol	Dimensions in mil		
	Min.	Nom.	Max.
A	173	—	181
B	64	—	72
C	90	—	102
D	35	—	47
E	155	—	167
F	14	—	19
G	17	—	22
H	—	59	—
I	55	—	63
J	14	—	17

Product Tape and Reel Specifications

TO-92 Reel Dimensions (Unit: mm)

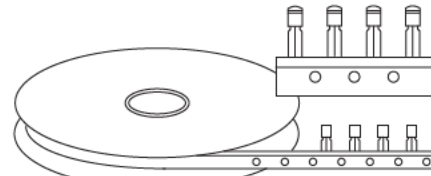
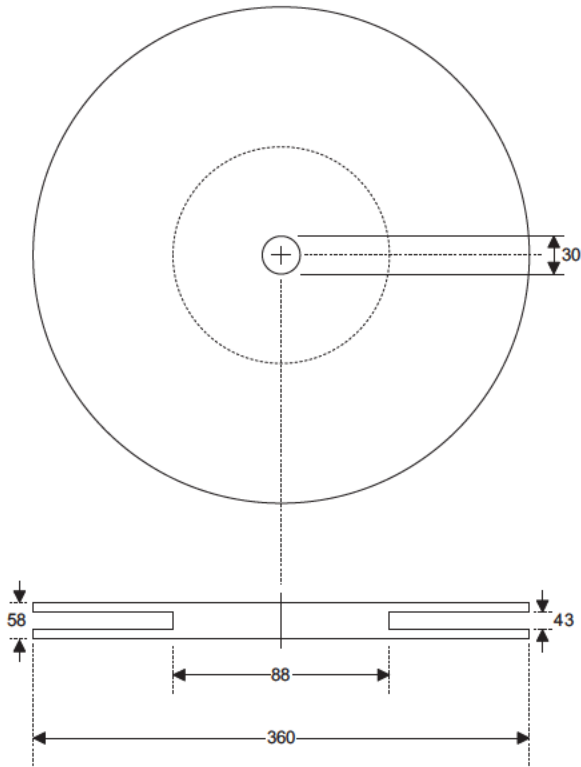

Package Up, Flat Side Up

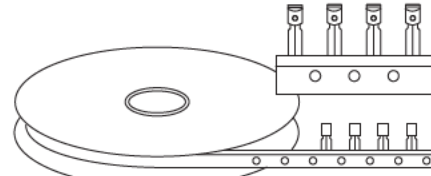

Package Up, Flat Side Down

SOT-89 Reel Dimensions

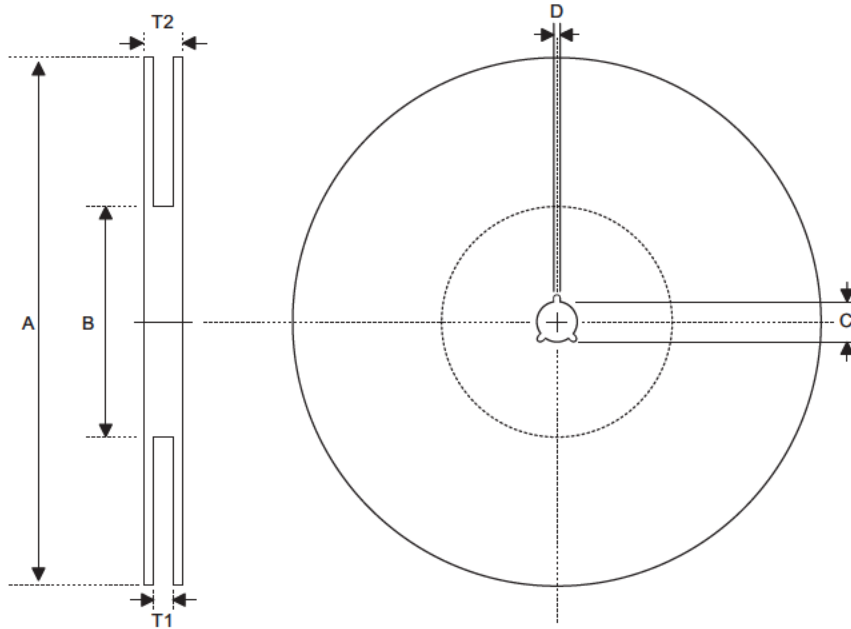

SOT 89

Symbol	Description	Dimensions in mm
A	Reel Outer Diameter	180±1.0
B	Reel Inner Diameter	62±1.5
C	Spindle Hole Diameter	12.75+0.15
D	Key Slit Width	1.9±0.15
T1	Space Between Flange	12.4+0.2
T2	Reel Thickness	17-0.4

TO-92 Carrier Tape Dimensions

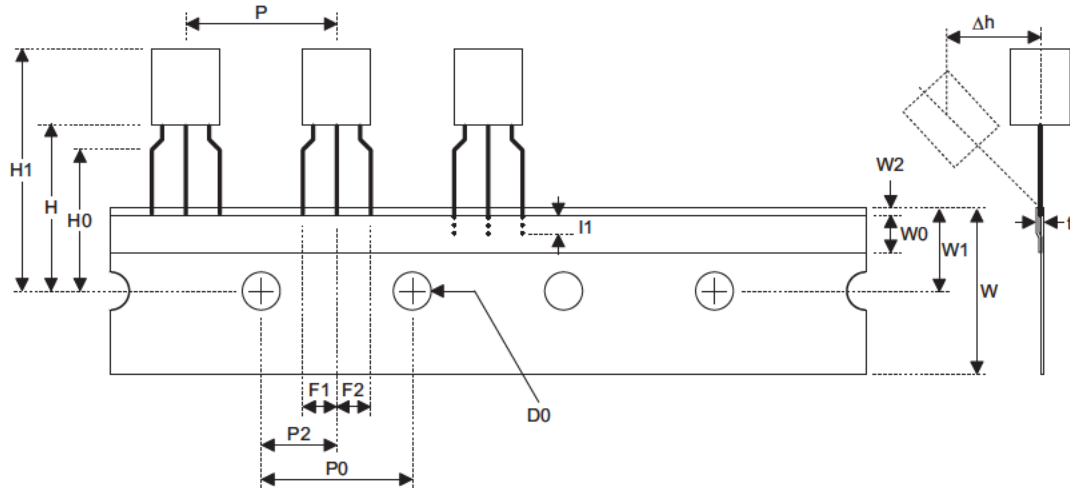

TO 92

Symbol	Description	Dimensions in mm
l1	Taped Lead Length	(2.5)
P	Component Pitch	12.7±1.0
P ₀	Perforation Pitch	12.7±0.3
P ₂	Component to Perforation (Length Direction)	6.35±0.4
F ₁	Lead Spread	2.5+0.4 -0.1
F ₂	Lead Spread	2.5+0.4 -0.1
Δh	Component Alignment	0±0.1
W	Carrier Tape Width	18.0+1.0 -0.5
W ₀	Hold down Tape Width	6.0±0.5
W ₁	Perforation Position	9.0±0.5
W ₂	Hold down Tape Position	(0.5)
H ₀	Lead Clinch Height	16.0±0.5
H ₁	Component Height	Less than 24.7
D ₀	Perforation Diameter	4.0±0.2
t	Taped Lead Thickness	0.7±0.2
H	Component Base Height	19.0±0.5

Note: Thickness less than 0.38±0.05mm~0.5mm
 P₀ Accumulated pitch tolerance: ±1mm/20pitches.
 () Bracketed figures are for consultation only

SOT-89 Carrier Tape Dimensions

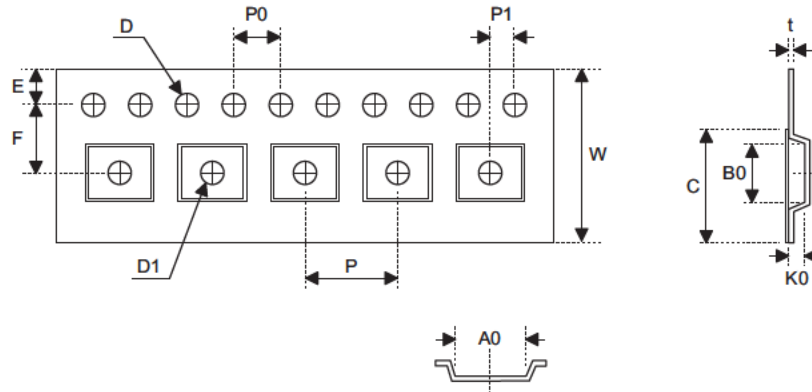

SOT 89

Symbol	Description	Dimensions in mm
W	Carrier Tape Width	12.0+0.3 -0.1
P	Cavity Pitch	8.0±0.1
E	Perforation Position	1.75±0.1
F	Cavity to Perforation (Width Direction)	5.5±0.05
D	Perforation Diameter	1.5+0.1
D1	Cavity Hole Diameter	1.5+0.1
P0	Perforation Pitch	4.0±0.1
P1	Cavity to Perforation (Length Direction)	2.0±0.10
A0	Cavity Length	4.8±0.1
B0	Cavity Width	4.5±0.1
K0	Cavity Depth	1.8±0.1
t	Carrier Tape Thickness	0.30±0.013
C	Cover Tape Width	9.3

Holtek Semiconductor Inc. (Headquarters)

No.3, Creation Rd. II, Science Park, Hsinchu, Taiwan
Tel: 886 3 563 1999
Fax: 886 3 563 1189
<http://www.holtek.com.tw>

Holtek Semiconductor Inc. (Taipei Sales Office)

4F 2, No. 3 2, YuanQu St., Nankang Software Park, Taipei 115, Taiwan
Tel: 886 2 2655 7070
Fax: 886 2 2655 7373
Fax: 886 2 2655 7383 (International sales hotline)

Holtek Semiconductor Inc. (Shanghai Sales Office)

7th Floor, Building 2, No.889, Yi Shan Rd., Shanghai, China 200233
Tel: 021 6485 5560
Fax: 021 6485 0313
<http://www.holtek.com.cn>

Holtek Semiconductor Inc. (Shenzhen Sales Office)

43F, SEG Plaza, Shen Nan Zhong Road, Shenzhen, China 518031
Tel:0755 83465589
Fax:0755 83465590
ISDN : 0755 8346559

Holtek Semiconductor Inc. (Beijing Sales Office)

Suite 1721, Jinyu Tower, A129 West Xuan Wu Men Street, Xicheng District, Beijing, China 100031
Tel:010 66410030, 66417751, 66417752
Fax:010 66410125

Holmate Semiconductor, Inc. (USA Sales Office)

46712 Fremont Blvd., Fremont, CA 94538
Tel: 510 252 9880
Fax: 510 252 9885
<http://www.holmate.com>

Copyright © 2004 by HOLTEK SEMICONDUCTOR INC.

The information appearing in this Data Sheet is believed to be accurate at the time of publication. However, Holtek assumes no responsibility arising from the use of the specifications described. The applications mentioned herein are used solely for the purpose of illustration and Holtek makes no warranty or representation that such applications will be suitable without further modification, nor recommends the use of its products for application that may present a risk to human life due to malfunction or otherwise. Holtek's products are not authorized for use as critical components in life support devices or systems. Holtek reserves the right to alter its products without prior notification. For the most up to date information, please visit our web site at <http://www.holtek.com.tw>.