

# MORNSUN®

## B\_XT-1WR2 Series

1W, FIXED INPUT, ISOLATED & UNREGULATED SINGLE OUTPUT



Patent Protected RoHS



Continuous Short Circuit Protection

### PART NUMBER SYSTEM

B0505XT-1WR2

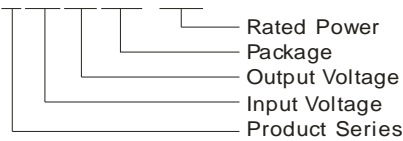

### FEATURES

- Miniature SMD package
- 1500VDC isolation
- Operating temperature range: -40°C~+105°C
- Internal SMD construction
- No external component required
- Industry standard pinout

### APPLICATIONS

The B\_XT-1WR2 Series are designed for application where isolated output is required from a distributed power system.

These products apply to where:

- 1) Input voltage rang  $\leq \pm 10\%$ ;
- 2) 1500VDC input and output isolation;
- 3) Regulated and low ripple noise is not required.

Such as: digital circuits, low frequency analog circuits, and relay drive circuit.

### SELECTION GUIDE

Model	Input Voltage(VDC) Nominal (Range)	Output Voltage (VDC)	Output Current (mA)		Input Current (mA)(Typ.)		Reflected Ripple Current (mA.Typ.)	Max.Capacitive Load( $\mu$ F)	Efficiency (%, Typ.) @Max. Load
			Max.	Min.	@Max. Load	@No Load			
B0303XT-1WR2	3.3 (2.97-3.63)	3.3	303	30	415	25	15	220	73
B0305XT-1WR2		5	200	20	388				78
B0503XT-1WR2	5 (4.5-5.5)	3.3	303	30	263	20			76
B0505XT-1WR2		5	200	20	250				80
B0509XT-1WR2		9	111	12	250				80
B0512XT-1WR2		12	84	9	250				80
B0515XT-1WR2		15	67	7	250				80
B0524XT-1WR2		24	42	4	250				80
B1203XT-1WR2	12 (10.8-13.2)	3.3	303	30	111	15			75
B1205XT-1WR2		5	200	20	104				80
B1209XT-1WR2		9	111	12	104				80
B1212XT-1WR2		12	84	9	103				81
B1215XT-1WR2		15	67	7	103		81		
B1515XT-1WR2	15 (13.5-16.5)	15	67	7	82	10	81		
B2405XT-1WR2	24 (21.6-26.4)	5	200	20	52	7	80		
B2409XT-1WR2		9	110	11	52		80		
B2415XT-1WR2		15	67	7	51		81		
B2424XT-1WR2		24	42	4	51		81		

### INPUT SPECIFICATIONS

Item	Test Conditions	Min.	Typ.	Max.	Unit
Input Surge Voltage (1 sec. max.)	3.3VDC Input	-0.7	--	5	VDC
	5VDC Input	-0.7	--	9	
	12VDC Input	-0.7	--	18	
	15VDC Input	-0.7	--	21	
	24VDC Input	-0.7	--	30	
Input Filter		Capacitance Filter			

## OUTPUT SPECIFICATIONS

Item	Test Conditions	Min.	Typ.	Max.	Unit
Output Voltage Accuracy		See tolerance envelope curve			
Line Regulation	For Vin change of $\pm 1\%$	3.3V output	--	--	$\pm 1.5$
		Others	--	--	$\pm 1.2$
Load Regulation	10% to 100% load	3.3V output	--	18	--
		5V output	--	12	--
		9V output	--	8	--
		12V output	--	7	--
		15V output	--	6	--
		24V output	--	5	--
Temperature Drift	100% load	--	--	$\pm 0.03$	%/ $^{\circ}\text{C}$
Ripple & Noise*	20MHz Bandwidth	Output Voltage $\leq 12\text{V}$	--	30	--
		Output Voltage: 15V, 24V	--	60	--
Short Circuit Protection		Continuous, automatic recovery			

Note:\* Ripple and noise tested with "parallel cable" method. See detailed operation instructions at DC-DC Application Notes.

## COMMON SPECIFICATIONS

Item	Test Conditions	Min.	Typ.	Max.	Unit
Isolation Voltage	Input-Output, tested for 1 minute and leakage current less than 1 mA	1500	--	--	VDC
Isolation Resistance	Input-Output, test at 500VDC	1000	--	--	M $\Omega$
Isolation Capacitance	Input-Output, 100KHz/0.1V	--	20	--	pF
Switching Frequency	Full load, nominal input	--	100	300	KHz
MTBF	MIL-HDBK-217F @25 $^{\circ}\text{C}$	3500	--	--	K hours
Case Material		Epoxy Resin (UL94-V0)			
Weight		--	1.5	--	g

## ENVIRONMENTAL SPECIFICATIONS

Item	Test Conditions	Min.	Typ.	Max.	Unit
Storage Humidity	Non condensing	--	--	95	%
Operating Temperature	Power derating (above 100 $^{\circ}\text{C}$ , see Figure 2)	-40	--	105	$^{\circ}\text{C}$
Storage Temperature		-55	--	125	
Temp. rise at full load	Ta=25 $^{\circ}\text{C}$	--	25	--	
Lead Temperature	1.5mm from case for 10 seconds	--	--	300	
Cooling		Free air convection			

## EMC SPECIFICATIONS

EMI	CE	CISPR22/EN55022 CLASS B (Recommended Circuit Refer to Figure1)			
	RE	CISPR22/EN55022 CLASS B (Recommended Circuit Refer to Figure1)			
EMS	ESD	IEC/EN61000-4-2 Contact $\pm 8\text{KV}$ perf. Criteria B			

## EMI RECOMMENDED CIRCUIT

EMI Typical Recommended Circuit(CLASS B):

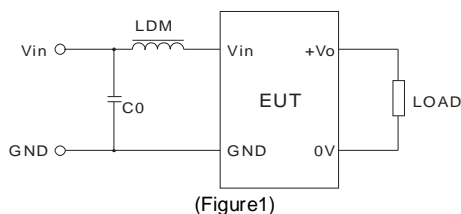

Recommended external circuit parameters:

	Vin(V)	3.3/5/12/15/24
EMI	C0	4.7 $\mu\text{F}$ /50V
	LDM	6.8 $\mu\text{H}$

## EMI TEST WAVEFORM (RECOMMENDED CIRCUIT FIGURE 1)

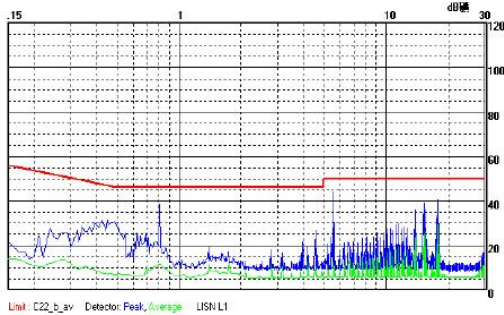

B0505XT-1WR2 CE(Class B, Positive line)

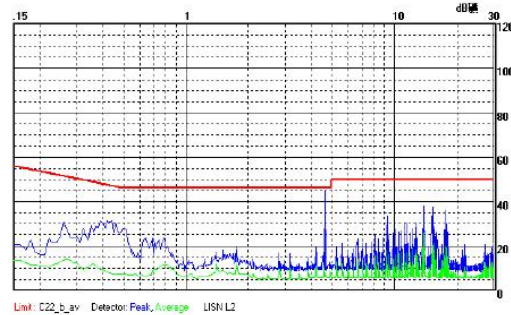

B0505XT-1WR2 CE(Class B, Negative line)

## PRODUCT TYPICAL CURVE

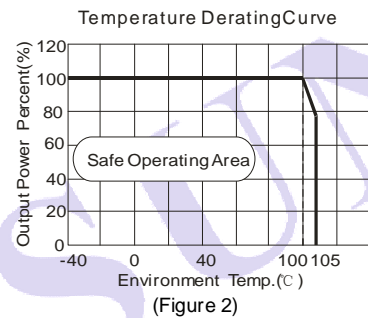
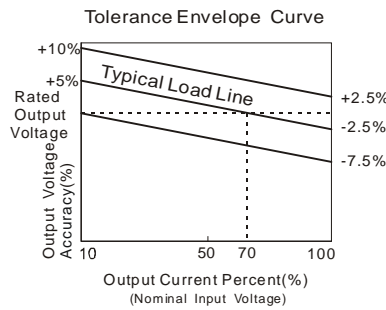

Efficiency VS Input Voltage curve (Full Load)

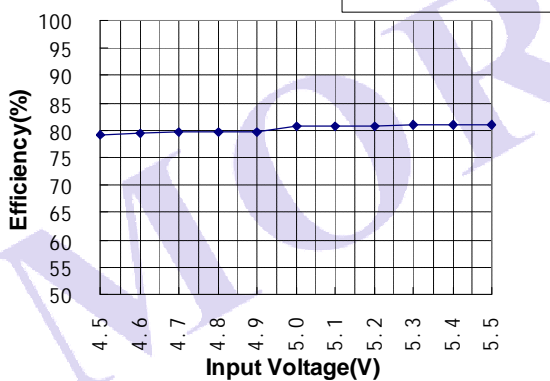

Efficiency VS Output Load curve (Vin=Vin-nominal)

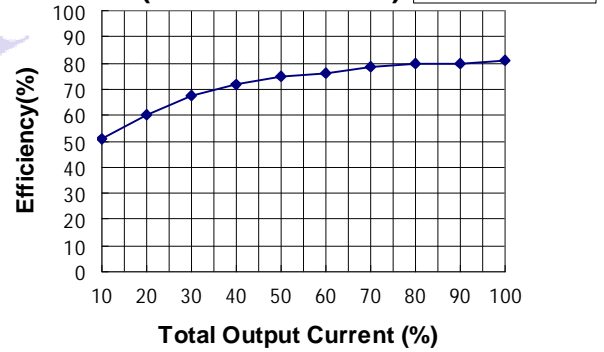

Efficiency VS Input Voltage curve (Full Load)

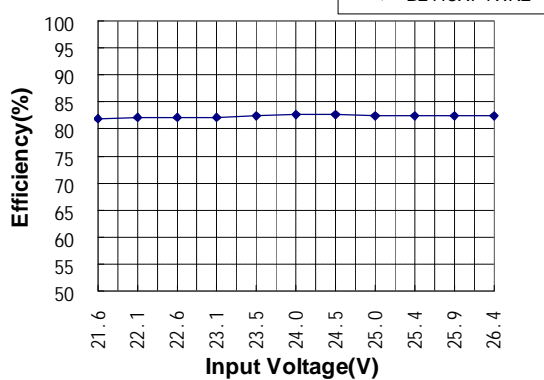

Efficiency VS Output Load curve (Vin=Vin-nominal)

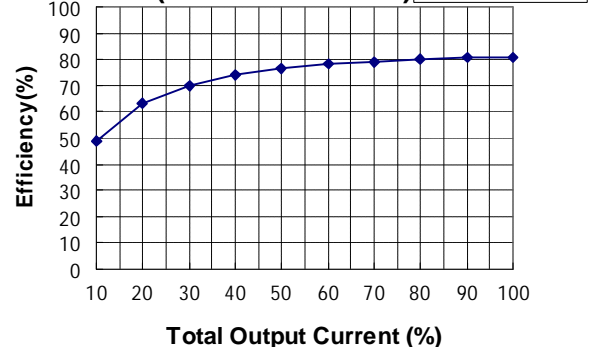

Recommended reflow soldering profile refer to IPC/JEDEC J-STD-020D standard, our products recommend reflow soldering profile as follows:

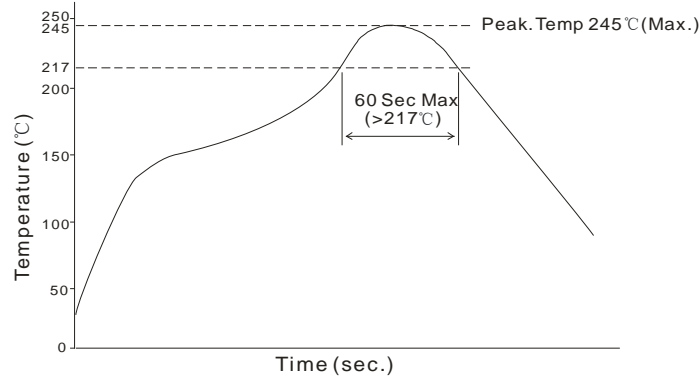

## DIMENSIONS, RECOMMENDED FOOTPRINT & PACKAGING

### MECHANICAL DIMENSIONS

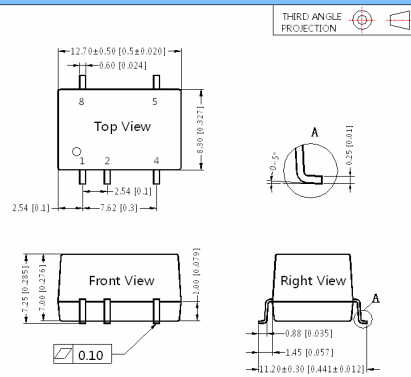

Note:  
Unit: mm[inch]  
Pin section tolerances:  $\pm 0.10[\pm 0.004]$   
General tolerances:  $\pm 0.25[\pm 0.010]$

### RECOMMENDED FOOTPRINT DETAILS

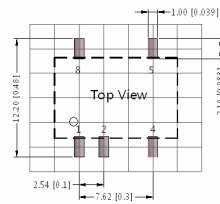

Note : Grid 2.54\*2.54mm

PIN CONNECTION	
Pin	Function
1	GND
2	Vin
4	0V
5	+Vo
8	NC

NC:No Connection

### TUBE PACKAGING DIMENSIONS

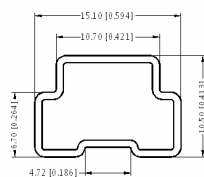

Note:  
Unit: mm[inch]  
General tolerances:  $\pm 0.50\text{mm}[\pm 0.020\text{inch}]$   
L=530[20.866inch] Quantity:40pcs  
L=220[8.661] Quantity:15pcs  
Inner carton(S):L\*W\*H=255\*170\*80  
Outer carton(S):L\*W\*H=375\*280\*270  
Inner carton(L):L\*W\*H=580\*200\*100  
Outer carton(L):L\*W\*H=600\*215\*220, 2 inner cartons(L)  
Outer carton(L):L\*W\*H=600\*215\*325, 3 inner cartons(L)

### REEL PACKAGING DIMENSIONS

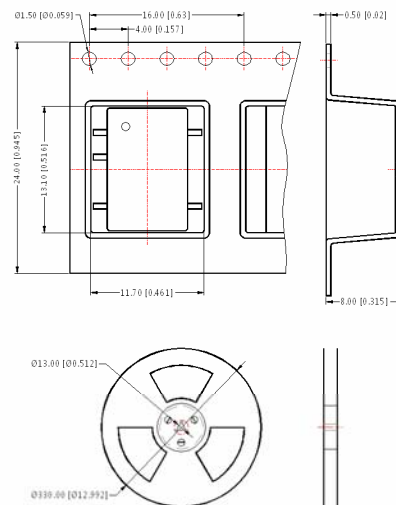

Note:  
Unit: mm[inch]  
General tolerances:  $\pm 0.50[\pm 0.020]$   
Per reel of packing quantity:500pcs  
Inner carton:L\*W\*H=365\*350\*105  
Quantity:2000pcs  
Outer carton:L\*W\*H=390\*360\*245  
Quantity:4000pcs

## TEST CONFIGURATIONS

### Input Reflected-Ripple Current Test Setup

Input reflected-ripple current is measured with an inductor  $L_{in}$  and Capacitor  $C_{in}$  to simulate source impedance.

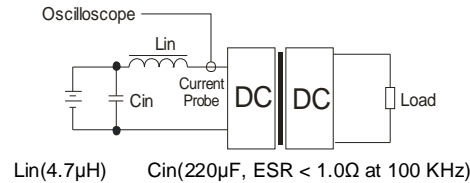

## DESIGN CONSIDERATIONS

### 1) Requirement on output load

To ensure this module can operate efficiently and reliably, During operation, the minimum output load could not be less than 10% of the full load. If the actual output power is very small, please connect a resistor with proper resistance at the output end in parallel to increase the load.

### 2) Overload Protection

Under normal operating conditions, the output circuit of these products has no protection against overload. The simplest method is to add a circuit breaker to the circuit.

### 3) Recommended circuit

If you want to further decrease the input/output ripple, an capacitor filtering network may be connected to the input and output ends of the DC/DC converter, see (Figure 3).

It should also be noted that the capacitance of filter capacitor must be proper. If the capacitance is too big, a startup problem might arise. For every channel of output, provided the safe and reliable operation is ensured, the recommended capacitance of its filter capacitor sees (Table 1).

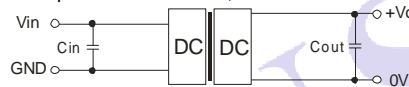

(Figure 3)

EXTERNAL CAPACITOR TABLE (Table 1)

$V_{in}$ (VDC)	$C_{in}$ ( $\mu F$ )	$V_o$ (VDC)	$C_{out}$ ( $\mu F$ )
3.3	4.7	3.3	10
5	4.7	5	10
12	2.2	9	4.7
15	2.2	12	2.2
24	1	15	1
-	--	24	0.47

It's not recommended to connect any external capacitor in the application field with less than 0.5 watt output.

**4) The input and the output of the product are recommended to be connected to ceramic capacitor or electrolytic capacitor. Using tantalum capacitor may cause risk of failure**

**5) It is not recommended to increase the output power capability by connecting two or more converters in parallel. The product is not hot-swappable**

Note:

1. Operation under minimum load will not damage the converter; However, they may not meet all specifications.
2. Max. Capacitive Load is tested at nominal input voltage and full load.
3. Unless otherwise noted, All specifications are measured at  $T_a=25^\circ C$ , humidity<75%, nominal input voltage and rated output load.
4. In this datasheet, all test methods are based on our corporate standards.
5. All characteristics are for listed models, and non-standard models may perform differently. Please contact our technical support for more detail.
6. Please contact our technical support for any specific requirement.
7. Specifications of this product are subject to changes without prior notice.

### **MORNSUN Science & Technology Co.,Ltd.**

Address: No. 5, Kehui St. 1, Kehui development center, Science Ave., Guangzhou Science City, Luogang district, Guangzhou, P.R.China.

Tel: 86-20-38601850

Fax: 86-20-38601272

E-mail: [info@mornsun.cn](mailto:info@mornsun.cn)

[Http://www.mornsun-power.com](http://www.mornsun-power.com)