

## Current Transducer LF 205-S/SP3

For the electronic measurement of currents: DC, AC, pulsed..., with galvanic separation between the primary circuit and the secondary circuit.

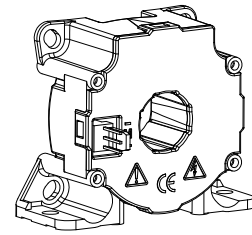

$$I_{PN} = 100 \text{ A}$$



### Electrical data

$I_{PN}$	Primary nominal rms current	100	A				
$I_{PM}$	Primary current, measuring range	0 .. $\pm 200$	A				
$R_M$	Measuring resistance @	$T_A = 70 \text{ }^\circ\text{C}$		$T_A = 85 \text{ }^\circ\text{C}$			
		$R_{M \min}$	$R_{M \max}$	$R_{M \min}$	$R_{M \max}$		
		with $\pm 12 \text{ V}$	@ $\pm 100 \text{ A}_{\max}$	0	95	15	94
			@ $\pm 200 \text{ A}_{\max}$	0	40	15	39
	with $\pm 15 \text{ V}$	@ $\pm 100 \text{ A}_{\max}$	16	123	47	122	
		@ $\pm 200 \text{ A}_{\max}$	16	55	47	54	
$I_{SN}$	Secondary nominal rms current	100	mA				
$K_N$	Conversion ratio	1 : 1000					
$U_C$	Supply voltage (+ 5 %)	$\pm 12 \dots 15$	V				
$I_C$	Current consumption @ $\pm 15 \text{ V}$	$17 + I_S$	mA				

### Accuracy - Dynamic performance data

$X_G$	Overall accuracy @ $I_{PN}$ , $T_A = 25 \text{ }^\circ\text{C}$	$\pm 0.5$	%
$\epsilon_L$	Linearity error	$< 0.1$	%
$I_O$	Offset current @ $I_P = 0$ , $T_A = 25 \text{ }^\circ\text{C}$	Typ	$\pm 0.2$
		Max	$\pm 0.2$
$I_{OM}$	Magnetic offset current <sup>1)</sup> @ $I_P = 0$ and specified $R_M$ , after an overload of $3 \times I_{PN}$		$\pm 0.1$
$I_{OT}$	Temperature variation of $I_O$ - $40 \text{ }^\circ\text{C} \dots + 85 \text{ }^\circ\text{C}$	$\pm 0.25$	$\pm 0.65$
$t_{ra}$	Reaction time to 10 % of $I_{PN}$ step	$< 500$	ns
$t_r$	Step response time <sup>2)</sup> to 90 % of $I_{PN}$	$< 1$	$\mu\text{s}$
$di/dt$	$di/dt$ accurately followed	$> 100$	A/ $\mu\text{s}$
$BW$	Frequency bandwidth (- 3 dB)	DC .. 100	kHz

### General data

$T_A$	Ambient operating temperature	- 40 .. + 85	$^\circ\text{C}$
$T_S$	Ambient storage temperature	- 40 .. + 90	$^\circ\text{C}$
$R_S$	Secondary coil resistance	@ $T_A = 70 \text{ }^\circ\text{C}$	10
		@ $T_A = 85 \text{ }^\circ\text{C}$	11
$m$	Mass	78	g
	Standard	EN 50178: 1997	

### Features

- Closed loop (compensated) current transducer using the Hall effect
- Insulating plastic case recognized according to UL 94-V0.

### Special features

- $I_{PN} = 100 \text{ A}$
- $I_{PM} = 0 \dots \pm 200 \text{ A}$
- $K_N = 1 : 1000$ .

### Advantages

- Excellent accuracy
- Very good linearity
- Low temperature drift
- Optimized response time
- Wide frequency bandwidth
- No insertion losses
- High immunity to external interference
- Current overload capability.

### Applications

- AC variable speed drives and servo motor drives
- Static converters for DC motor drives
- Battery supplied applications
- Uninterruptible Power Supplies (UPS)
- Switched Mode Power Supplies (SMPS)
- Power supplies for welding applications.

### Application domain

- Industrial.

**Notes:** <sup>1)</sup> The result of the coercive force (Hc) of the magnetic circuit

<sup>2)</sup> With a  $di/dt$  of 100 A/ $\mu\text{s}$ .

## Current Transducer LF 205-S/SP3

### Isolation characteristics

$U_d$	Rms voltage for AC insulation test, 50/60 Hz, 1 min	3.5	kV
$\hat{U}_W$	Impulse withstand voltage 1.2/50 $\mu$ s	8.8	kV
$U_e$	Partial discharge extinction voltage rms @ 10 pC	> 2	kV
		Min	
$d_{Cp}$	Creepage distance	11	mm
$d_{Cl}$	Clearance	10.2	mm
$CTI$	Comparative Tracking Index (group IIIa)	175	

### Applications examples

According to EN 50178 and IEC 61010-1 standards and following conditions:

- Over voltage category OV 3
- Pollution degree PD2
- Non-uniform field

	EN 50178	IEC 61010-1
$d_{Cp}, d_{Cl}, \hat{U}_W$	Rated insulation voltage	Nominal voltage
Basic insulation	500 V	500 V
Reinforced insulation	250 V	250 V

### Safety

This transducer must be used in limited-energy secondary circuits according to IEC 61010-1.



This transducer must be used in electric/electronic equipment with respect to applicable standards and safety requirements in accordance with the manufacturer's operating instructions.



Caution, risk of electrical shock

When operating the transducer, certain parts of the module can carry hazardous voltage (eg. primary busbar, power supply).

Ignoring this warning can lead to injury and/or cause serious damage.

This transducer is a build-in device, whose conducting parts must be inaccessible after installation.

A protective housing or additional shield could be used.

Main supply must be able to be disconnected.

## Dimensions LF 205-S/SP3 (in mm)

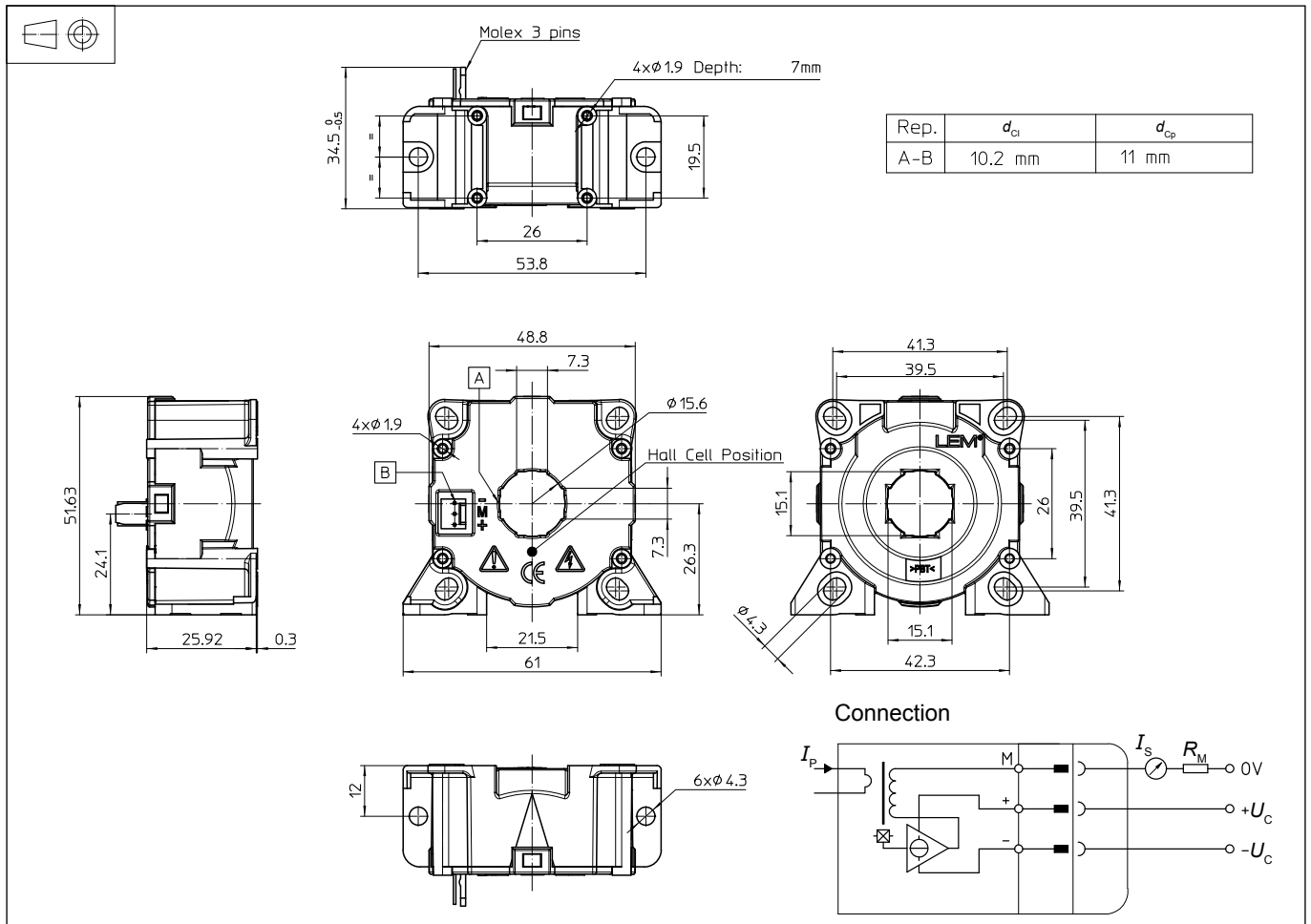

### Mechanical characteristics

- General tolerance  $\pm 0.2$  mm
- Transducer fastening
  - Vertical position
    - 2 holes  $\varnothing 4.3$  mm
    - 2 steel screws M4
    - Recommended fastening torque 2.3 N·m
    - Or
      - 4 holes  $\varnothing 1.9$  mm
      - depth: 7 mm
      - 4 screws PTKA 25
      - length: 6 mm
  - Horizontal position
    - 4 holes  $\varnothing 4.3$  mm
    - 4 steel screws M4
    - Recommended fastening torque 3.2 N·m
    - Or
      - 4 holes  $\varnothing 1.9$  mm
      - 4 screws PTKA 25
      - min length: 11.5 mm with thickness of fixed plate
    - Recommended fastening torque 0.7 N·m
- Primary through-hole  $\varnothing 15.5$  mm
- Connection of secondary
  - $\varnothing 15.5$  mm
  - Molex 6410
  - 3 Tin plated pins

### Remarks

- $I_s$  is positive when  $I_p$  flows in the direction of the arrow.
- Temperature of the primary conductor should not exceed 100 °C.
- Dynamic performances ( $di/dt$  and response time) are best with a single bar completely filling the primary hole.