

The information provided herein is from CONNELY Electronic Co., Ltd. and is confidential. Any disclosure to a party other than the recipient is prohibited. The intellectual properties and its rights contained herein, including but not limited to, trademarks, patents, copyrights, trade secrets, and technical know-how, are owned exclusively by CONNELY or its affiliates. Unauthorized use or disclosure of any information hereon may result in legal action. CONNELY may enforce its intellectual property rights at its own discretion, failures or delays to exercise such rights does not constitute a waiver of such rights.

REV.	DESCRIPTION	DRAWN	CHECKED	APPROVED
A	NEW RELEASE	LJH 06/28/05'		LJC 06/28/05'
E	DRAWING UPDATE	JLZ 04/25/19'		

Male V/T TYPE

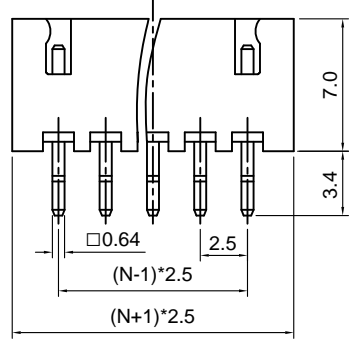

Male Right Angle

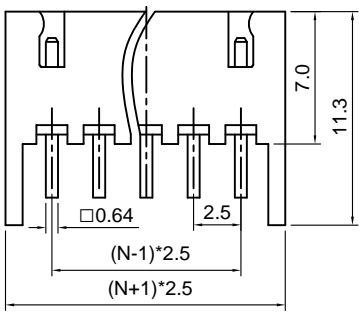

N=No. of contact

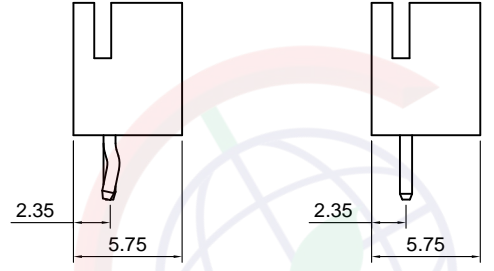

W/ kink

W/O kink

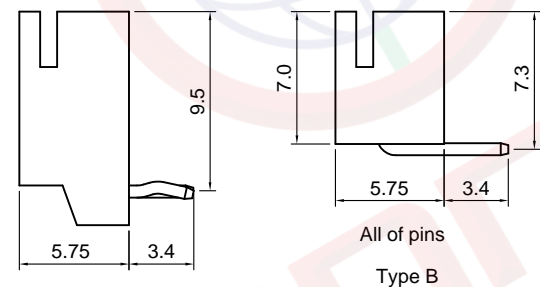

2-7(include) pins

All of pins

Type B

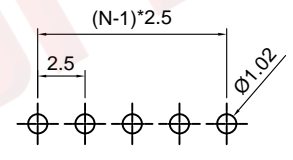

Recommend PCB layout (Tolerance:±0.05)

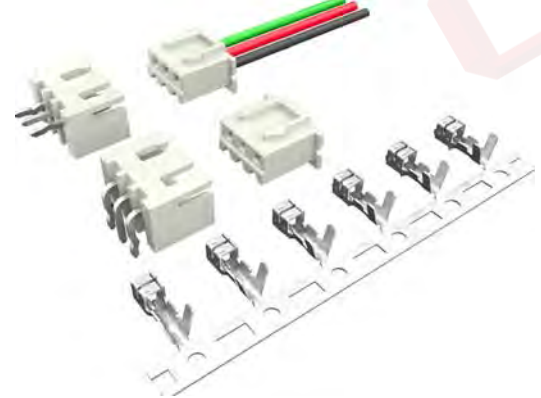

(Series Image-Reference Only)

NOTES:

- Main specifications
  - Housing material: Nylon 66
  - Wire range: AWG#28~#22
  - Rated voltage: 250V
  - Rated current: 3A(22AWG)
  - Contact resistance: 30mΩ
  - Insulation resistance: 1000MΩ
  - Withstanding voltage: 500V,AC 1 minute
  - Temperature range: -25 ~ +85°C
  - Recommend PC board thickness:1.6mm

2. Product number code:

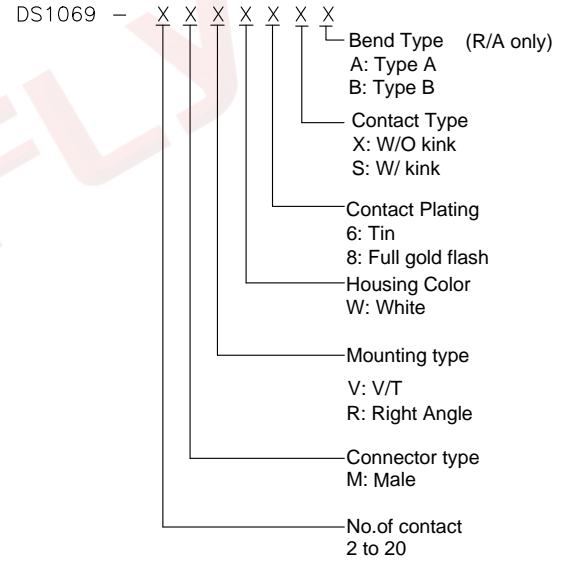

GENERAL TOLERANCE		ANGLE TOLERANCE		PROJECTION		TITLE	
X.	±0.60	X.	±5°	UNITS	mm	P.C.B CONNECTOR 2.5mm XH TYPE	
.X	±0.38	.X	±3°	SHEET SIZE	A4	SERIES	DS1069 SERIES
.XX	±0.25	.XX	±2°	<b>晨翔电子有限公司</b> CONNELY ELECTRONIC CO., LTD			
DRAWING TYPE		CUSTOMER					
SCALE	1:1	SHEET	1 OF 2				
DRAWING NO.		C-DS1069-XXXXX-E					

Dept	
Qty	
DC	1
ED	1
IE	1
ISO	1
PD	1
R&D	1
SD	1
QA	1
QC	1
QE	1

The information provided herein is from CONNELY Electronic Co., Ltd. and is confidential. Any disclosure to a party other than the recipient is prohibited. The intellectual properties and its rights contained herein, including but not limited to, trademarks, patents, copyrights, trade secrets, and technical know-how, are owned exclusively by CONNELY or its affiliates. Unauthorized use or reproduction of any part of this document for any purpose without the prior written permission of CONNELY is strictly prohibited. CONNELY may enforce its intellectual property rights at its own discretion, failures or delays to exercise such rights does not constitute a waiver of such rights.

Female Terminal

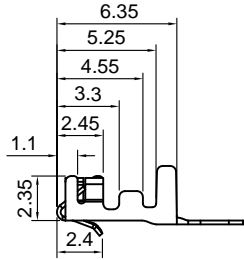

Female Housing

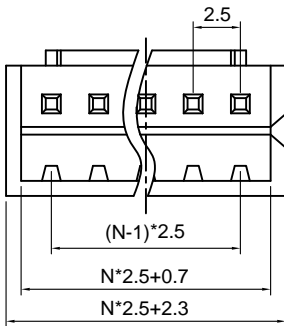
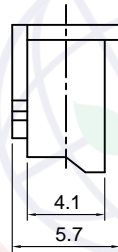
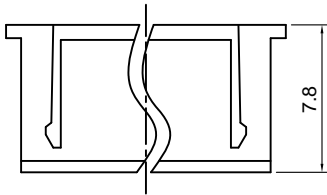

N=No. of contact

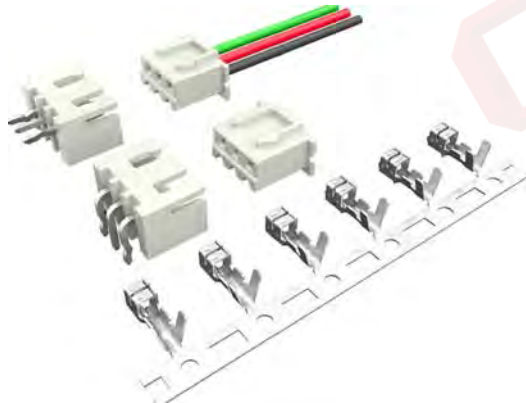

(Series Image-Reference Only)

REV.	DESCRIPTION	DRAWN	CHECKED	APPROVED
A	NEW RELEASE	LJH 06/28/05'		LJC 06/28/05'
E	DRAWING UPDATE	JLZ 04/25/19'		

NOTES:

- Main specifications
  - Housing material: Nylon 66
  - Wire range: AWG#28~#22
  - Rated voltage: 250V
  - Rated current: 3A(22AWG)
  - Contact resistance: 30mΩ
  - Insulation resistance: 1000MΩ
  - Withstanding voltage: 500V,AC 1 minute
  - Temperature range: -25 ~ +85°C
  - Recommend PC board thickness:1.6mm

2. Product number code:

Female Terminal

T-DS1069-S C 6 0 0  
 Contact Plating  
 6: Tin

Wire Range		O.D of Wire
Section Area (mm) <sup>2</sup>	AWG#	mm
0.08~0.33	28~22	1.2~1.9

Female Housing

I-DS1069-S C W 0 X  
 No. of contact  
 02~20

GENERAL TOLERANCE		ANGLE TOLERANCE		PROJECTION		TITLE	
X.	±0.60	X.	±5°	UNITS	mm	P.C.B CONNECTOR 2.5mm XH TYPE	
.X	±0.38	.X	±3°	SHEET SIZE	A4	SERIES	DS1069 SERIES
.XX	±0.25	.XX	±2°	晨翔电子有限公司 CONNELY ELECTRONIC CO., LTD			
DRAWING TYPE		CUSTOMER					
SCALE	1:1	SHEET	2 OF 2				
DRAWING NO.		C-DS1069-XXXXX-E					

REV.	DESCRIPTION	DRAWN	CHECKED	APPROVED
A	NEW RELEASE	LJC 07/09/14'		LJC 07/09/14'
B	DRAWING UPDATE	JLZ 06/26/17'		

Notes:  
 1.Materials: Phosphor Bronze.  
 2.Packing Type: Reel Paper, 6Kpcs/Reel.  
 3.Wire range:22~28AWG  
 4.Part Number Code:  
 T - DS1069 - S C X 0 0

Plating:  
 6: Full Tin(pre-plating).

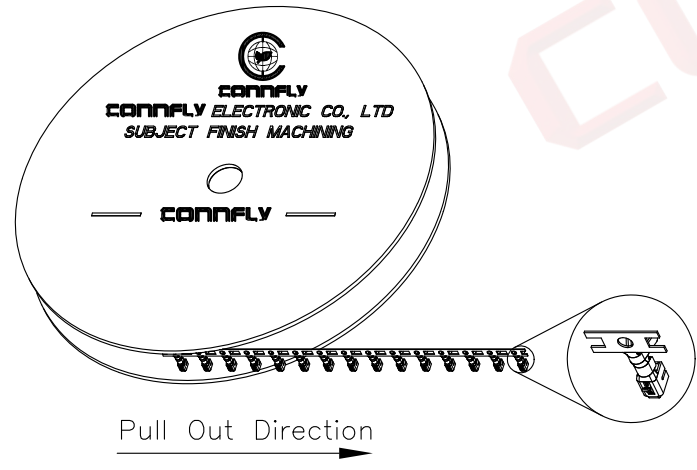
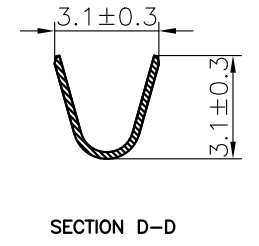
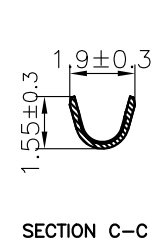
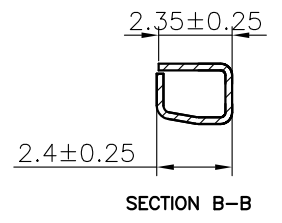
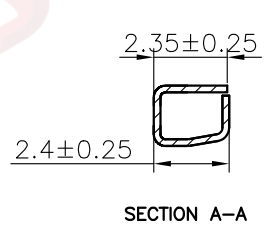
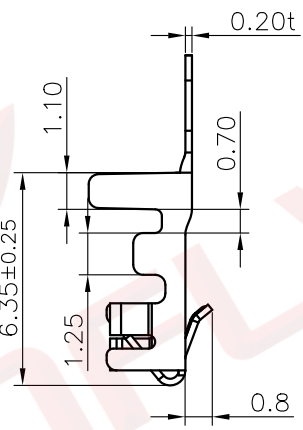
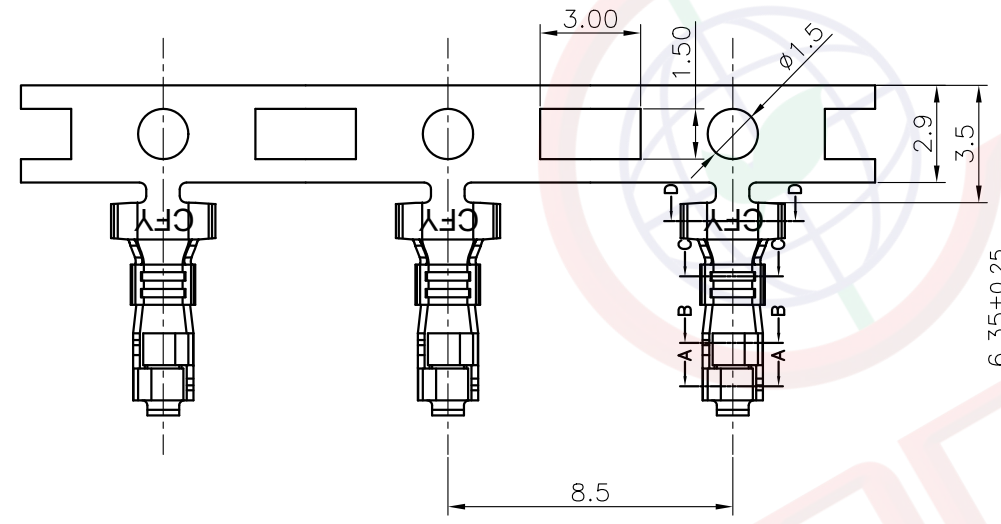

GENERAL TOLERANCE		ANGLE TOLERANCE	
X.	±0.60	X.	±5°
.X	±0.38	.X	±3°
.XX	±0.25	.XX	±2°
DRAWING TYPE		CUSTOMER	
SCALE	1:1	SHEET	1 OF 1
DRAWING NO.		T-DS1069-SCX00-B	

PROJECTION		TITLE	XH TERMINAL	
UNITS	mm			
SHEET SIZE	A4	SERIES	DS1069 SERIES	
		晨翔电子有限公司		
CONNFLY		CONNFLY ELECTRONIC CO. LTD		