

REV.	DESCRIPTION	DRAWN	CHECKED	APPROVED
A	NEW RELEASE	LJH 06/22/05'		LJC 06/22/05'
B	ADD P/N CODE	JLZ 03/19/16'	HZW 03/19/16'	LJC 03/19/16'
C	DRAWING UPDATE	JLZ 05/16/17'		

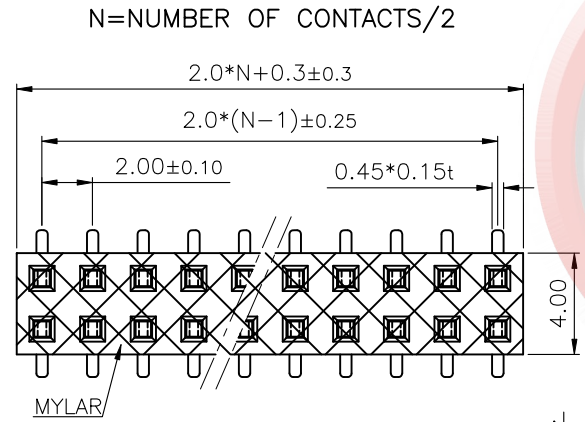

NOTES:

- MATERIALS:
 - CONTACT: COPPER ALLOY.
 - INSULATOR: HIGH TEMPERATURE PLASTIC,UL94 V-0 RATED
- ELECTRICAL CHARACTERISTICS:
 - CONTACT RESISTANCE: 20mΩ Max. INITIAL.
 - DIELECTRIC WITHSTANDING VOLTAGE: 500V AC(rms) FOR 1 MINUTE.
 - INSULATION RESISTANCE: 1000MΩ Min.
 - CURRENT RATING:1.5A.
- ENVIRONMENT CHARACTERISTICS:
 - OPERATING TEMPERATURE: -40°C~+105°C.
 - RECOMMEND SOLDERING HEAT:260°C,3~5s.
- PACKING TYPE: TAPE ON REEL OR TUBE.
- PRODUCT NUMBER CODE: DS1026-08 - X X X X X X X X

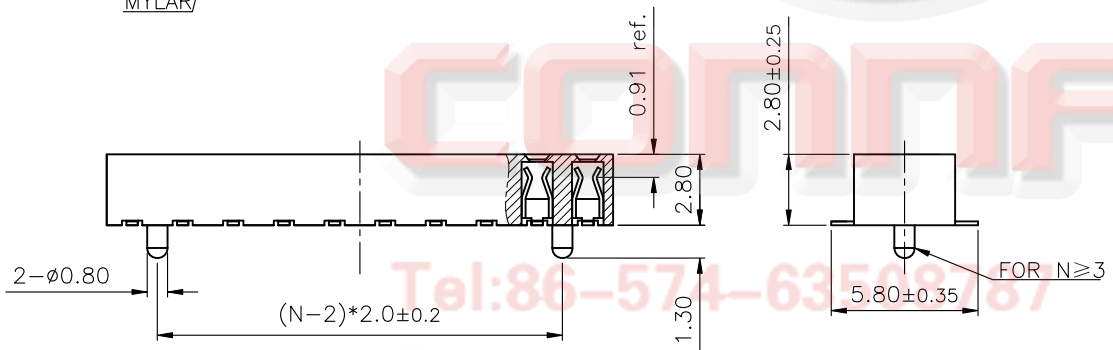

- PACKING TYPE
- R:TAPE ON REEL
- B:TUBE
- MYLAR SUPPORT
- S:W/ MYLAR
- X:W/O MYLAR
- POST SUPPORT
- X:W/O POST
- S:W/ POST
- CONTACTS TYPE
- S:SMT
- HOUSING COLOR
- B:BLACK
- CONTACT PLATING
- 8: FULL GOLD FLASH
- CONNECTOR TYPE
- S:SOCKET
- No.OF CONTACTS
- 2*2~2*40

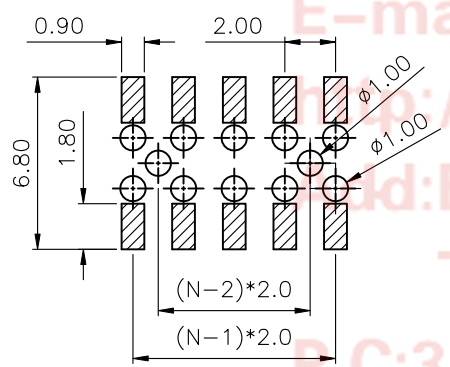

RECOMMEND PCB LAYOUT
(TOLERANCE=±0.05)

GENERAL TOLERANCE		ANGLE TOLERANCE	
X.	±0.60	X.	±5°
.X	±0.38	.X	±3°
.XX	±0.25	.XX	±2°
DRAWING TYPE		CUSTOMER	
SCALE	1:1	SHEET	1 OF 1
DRAWING NO.	C-DS1026-08-XXXXXXX-C		

PROJECTION		TITLE	2.00mm Female Header Double Row
UNITS	mm	V/T SMT Type H=2.8mm	
SHEET SIZE	A4	SERIES	DS1026-08 SERIES

晨翔电子有限公司
CONNFLY CONNFLY ELECTRONIC CO. LTD

Tel:86-574-63510817
Fax:86-574-63510817
E-mail:sale@connfly.com
http://www.connfly.com
Address:East Industry Zone KuangYan
Town Cixi Ningbo China
P.C:315333