

| REVISION RECORD |     |                |       |          |
|-----------------|-----|----------------|-------|----------|
| REV             | ECD | DESCRIPTION    | DRFT  | DATE     |
| △               |     | 增加UL刻字         | LJH   | 03/20/08 |
| △               |     | 增加VDE, CE刻字及参数 | Zengy | 06/30/08 |

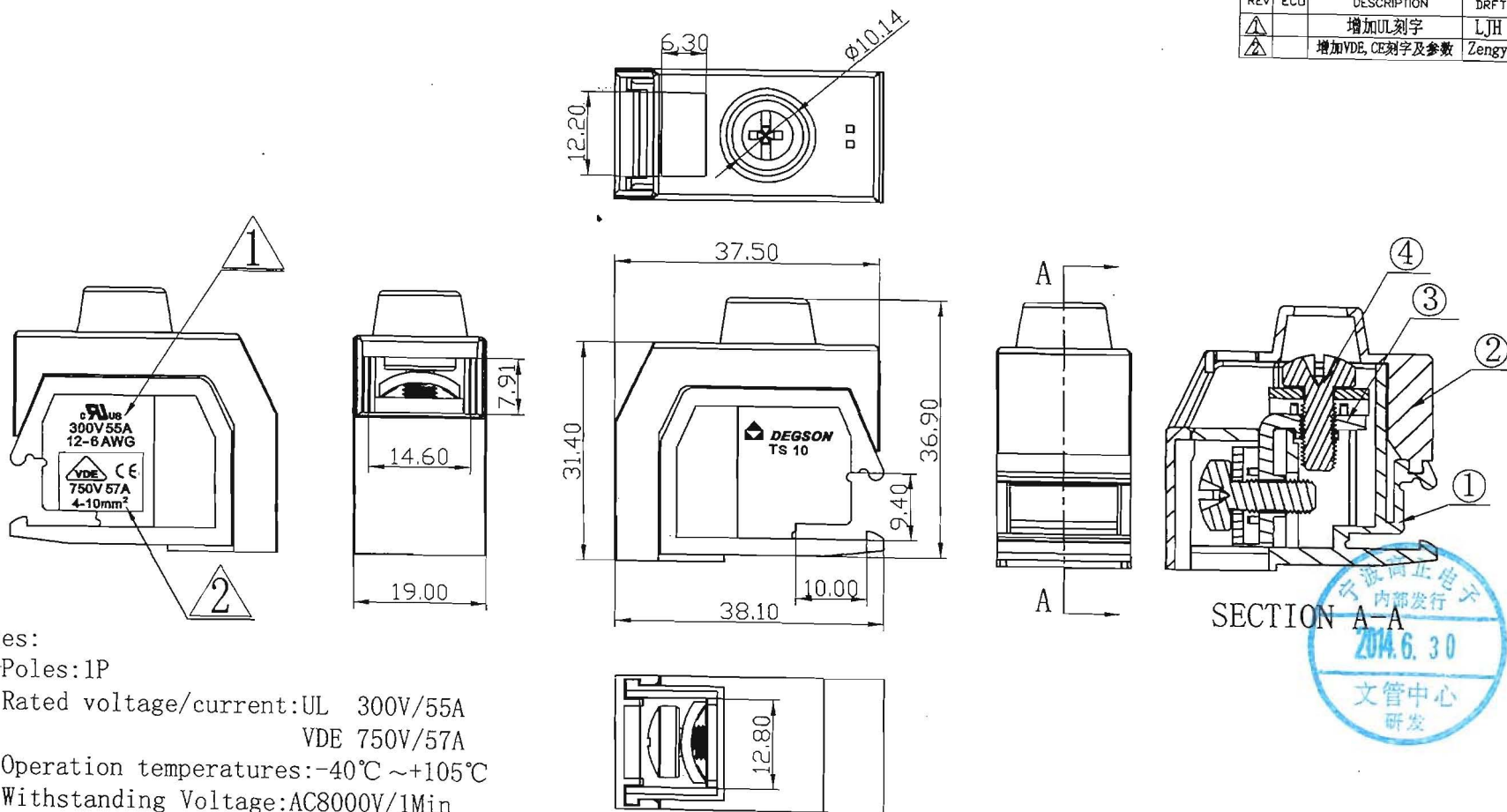

Notes:

1. Poles: 1P
2. Rated voltage/current: UL 300V/55A  
VDE 750V/57A
3. Operation temperatures: -40°C ~ +105°C
4. Withstanding Voltage: AC8000V/1Min
5. Insulation Resistance: 5000MΩ/DC1000V
6. Wire Range: 12~6AWG, 4.0~10mm<sup>2</sup>
7. Max. Torque Value: M5.0, 20.40kgf.cm
8. Undimensioned Tolerances:

| Pitch range in mm |       | Nominal dimension range in mm |      |      |      |      |      |         |
|-------------------|-------|-------------------------------|------|------|------|------|------|---------|
| to                | over  | to                            | over | over | over | over |      |         |
| 6                 | 10    | 30                            | 60   | 100  | 150  |      | ⌒    |         |
| 6                 | 10    | 24                            | 30   | 60   | 100  | 150  | ▭    |         |
| ±0.10             | ±0.15 | ±0.25                         | ±0.2 | ±0.3 | ±0.5 | ±0.7 | ±1.0 | 0.05/10 |

| ITEM | NAME OF PART         | NO. OF PART    | Q'TY | MATERIAL | NOTES               |
|------|----------------------|----------------|------|----------|---------------------|
| 4    | TS10-SCREW (M5.0*12) | S000002550 (H) | 2    | Steel    | Cr <sup>3+</sup> Zn |
| 3    | TS10-Current Carrier | 7005B00010 (H) | 1    | Copper   | SnCe                |
| 2    | TS10-COVER           | 7005C1501A (H) | 1    | PA66     | UL94V-0             |
| 1    | TS10-HOUSING         | 7005A1501A (H) | 1    | PA66     | UL94V-0             |

|                      |                            |   |   |         |   |      |   |   |   |
|----------------------|----------------------------|---|---|---------|---|------|---|---|---|
| DETACHED LISTS       | TOLERANCES EXCEPT AS NOTED | MM (INCH)   | ± | ±       | ± | ±    | ± | ± | ± |
|                      | ANGLES ± °                 |   |   |         |   |      |   |   |   |
|                      | THIRD ANGLE PROJECTION     |   |   |         |   |      |   |   |   |
|                      | SCALE: 1:1                 |   |   |         |   |      |   |   |   |
| DFTO L.Y.K.          |                            | DATE 07/10/07                                     |   |         |   |      |   |   |   |
| CHKD <i>Hy</i>       |                            | DATE 07/17/08                                     |   |         |   |      |   |   |   |
| MFO                  |                            | DATE  |   |         |   |      |   |   |   |
| APPVL <i>Hong</i>    |                            | DATE 07/18/08                                     |   |         |   |      |   |   |   |
| MATERIAL:            |                            |   |   |         |   |      |   |   |   |
| G.E.:                |                            |   |   |         |   |      |   |   |   |
| FINISH:              |                            |   |   |         |   |      |   |   |   |
| NAME                 |                            | DEGSON® 宁波高正电子有限公司<br>DEGSON ELECTRONICS CO., LTD |   |         |   |      |   |   |   |
| DRAWING NO. TS10-E02 |                            | SIZE A3   |   | REV 12  |   |      |   |   |   |
| /PART NO.            |                            | DO NOT SCALE DRAWING                              |   | SHEET 1 |   | OF 1 |   |   |   |