



**WINSTAR Display Co.,Ltd.**  
**華凌光電股份有限公司**



**Winstar Display Co., LTD**

**華凌光電股份有限公司**



WEB: <https://www.winstar.com.tw> E-mail: sales@winstar.com.tw

## SPECIFICATION

**CUSTOMER :** \_\_\_\_\_

**MODULE NO.:** WG320240B0-TMITZ#030

|  |  |
|--|--|
| <b>APPROVED BY:</b><br>( FOR CUSTOMER USE ONLY ) | <b>PCB VERSION:</b> _____ <b>DATA:</b> _____ |
|--|--|

| SALES BY | APPROVED BY | CHECKED BY | PREPARED BY |
|----------|-------------|------------|-------------|
|          |             |            |             |

| VERSION | DATE       | REVISED<br>PAGE NO. | SUMMARY                                     |
|---------|------------|---------------------|---|
| H       | 2019/08/27 |                     | Modify Material List of Components for RoHs |



| RECORDS OF REVISION |            |                  | DOC. FIRST ISSUE  |
|---------------------|------------|------------------|---|
| VERSION             | DATE       | REVISED PAGE NO. | SUMMARY   |
| 0                   | 2009/12/16 |                  | First issue   |
| A                   | 2010/07/09 |                  | Correct touch panel   |
| B                   | 2012/02/28 |                  | Modify backlight information.   |
| C                   | 2016/01/21 |                  | Remove IC information<br>Modify Response Time & Interface                             |
| D                   | 2016/01/27 |                  | Modify Precautions in use of LCD Modules & Static electricity test & Length of cable. |
| E                   | 2017/02/03 |                  | Modify Backlight Information  |
| F                   | 2017/10/24 |                  | Modify IDD  |
| G                   | 2019/03/25 |                  | Modify PIN18=NC   |
| H                   | 2019/08/27 |                  | Modify Material List of Components for RoHs   |

# Contents

- 1.Module Classification Information
- 2.Precautions in use of LCD Modules
- 3.General Specification
- 4.Absolute Maximum Ratings
- 5.Electrical Characteristics
- 6.Optical Characteristics
- 7.Interface Pin Function
- 8.Contour Drawing &Block Diagram
- 9.Reliability
- 10.Backlight Information
- 11.TouchPanel Information
- 12.Inspection specification
- 13.Material List of Components for RoHs
- 14.Recommendable Storage

# 1. Module Classification Information

W    G            320240            B0    —    T    M    I    —    TZ#030  
 ①    ②                    ③                    ④                    ⑤    ⑥    ⑦                    ⑧

① Brand : WINSTAR DISPLAY CORPORATION

② Display Type : H→Character Type, G→Graphic Type , X→TAB Type, O→COG Type

③ Display Font : 320 \* 240 dot

④ Model serials no.

⑤ Backlight Type :

|                     |                   |                         |
|---------------------|-------------------|-------------------------|
| N→Without backlight | T→LED, White      | L→LED, Full color       |
| B→EL, Blue green    | A→LED, Amber      | J→DIP LED,Blue          |
| D→EL, Green         | R→LED, Red        | K→DIP LED,White         |
| W→EL, White         | O→LED, Orange     | E→DIP LED, Yellow Green |
| M→EL, Yellow Green  | G→LED, Green      | H→DIP LED,Amber         |
| F→CCFL, White       | P→LED, Blue       | I→DIP LED, Red          |
| Y→LED, Yellow Green | X→LED, Dual color |                         |
| G→LED, Green        | C→LED, Full color |                         |

⑥ LCD Mode :

|                              |                               |
|------------------------------|-------------------------------|
| B→TN Positive, Gray          | V→FSTN Negative, Blue         |
| N→TN Negative,               | T→FSTN Negative, Black        |
| L→VA Negative                | D→FSTN Negative (Double film) |
| H→ HTN Positive, Gray        | F→FSTN Positive               |
| I→HTN Negative, Black        | K→FSC Negative                |
| U→HTN Negative, Blue         | S→FSC Positive                |
| M→STN Negative, Blue         | E→ISTN Negative, Black        |
| G→STN Positive, Gray         | C→CSTN Negative, Black        |
| Y→STN Positive, Yellow Green | A→ASTN Negative, Black        |

⑦ LCD Polarize Type/ Temperature range/ View direction

|                            |                            |
|----------------------------|----------------------------|
| A→Reflective, N.T, 6:00    | H→Transflective, W.T,6:00  |
| D→Reflective, N.T, 12:00   | K→Transflective, W.T,12:00 |
| G→Reflective, W. T, 6:00   | C→Transmissive, N.T,6:00   |
| J→Reflective, W. T, 12:00  | F→Transmissive, N.T,12:00  |
| B→Transflective, N.T,6:00  | I→Transmissive, W. T, 6:00 |
| E→Transflective, N.T.12:00 | L→Transmissive, W.T,12:00  |

⑧ Special Code

T : Build in Negative Voltage & Temperature Compensation  
 Z:IC NT7086  
 #:Fit in with the ROHS Directions and regulations  
 03:Sales code 0:Version(Add TS,J80=0)

## **2.Precautions in use of LCD Modules**

- (1) Avoid applying excessive shocks to the module or making any alterations or modifications to it.
- (2) Don't make extra holes on the printed circuit board, modify its shape or change the components of LCD module.
- (3) Don't disassemble the LCM.
- (4) Don't operate it above the absolute maximum rating.
- (5) Don't drop, bend or twist LCM.
- (6) Soldering: only to the I/O terminals.
- (7) Storage: please storage in anti-static electricity container and clean environment.
- (8) Winstar have the right to change the passive components, including R3,R6 & backlight adjust resistors. (Resistors,capacitors and other passive components will have different appearance and color caused by the different supplier.)
- (9) Winstar have the right to change the PCB Rev. (In order to satisfy the supplying stability, management optimization and the best product performance...etc, under the premise of not affecting the electrical characteristics and external dimensions, Winstar have the right to modify the version.)
- (10) To ensure the stability of the display screen, please apply screen saver after showing 30 mins of fixed display content.

### **3.General Specification**

| <b>Item</b>      | <b>Dimension</b>   | <b>Unit</b> |
|------------------|--|-------------|
| Number of dots   | 320x240  | —           |
| Module dimension | 160.0 x 109.0 x 15.0 (MAX)   | mm          |
| View area        | 122.0 x 92.0   | mm          |
| Active area      | 115.18 x 86.38   | mm          |
| Dot size         | 0.34 x 0.34  | mm          |
| Dot pitch        | 0.36 x 0.36  | mm          |
| LCD type         | STN Negative, Blue Transmissive<br>(In LCD production, It will occur slightly color difference. We can only guarantee the same color in the same batch.) |             |
| Duty             | 1/240  |             |
| View direction   | 6 o'clock  |             |
| Backlight Type   | LED White  |             |
| IC               | RA8835   |             |

## 4. Absolute Maximum Ratings

| Item                     | Symbol          | Min  | Typ | Max          | Unit |
|--------------------------|-----------------|------|-----|--------------|------|
| Operating Temperature    | $T_{OP}$        | -20  | —   | +70          | °C   |
| Storage Temperature      | $T_{ST}$        | -30  | —   | +80          | °C   |
| Input Voltage            | $V_{IN}$        | -0.3 | —   | $V_{DD}+0.3$ | V    |
| Supply Voltage For Logic | $V_{DD}-V_{SS}$ | -0.3 | —   | 7.0          | V    |
| Supply Voltage For LCD   | $V_{DD}-V_0$    | 0    | —   | 32           | V    |



## 5. Electrical Characteristics

| ITEM                     | SYMBOL          | CONDITION                 | MIN.        | TYP. | MAX.        | UNIT |
|--------------------------|-----------------|---------------------------|-------------|------|-------------|------|
| Supply Voltage For Logic | $V_{DD}-V_{SS}$ | —                         | 4.5         | 5.0  | 5.5         | V    |
| Supply Voltage For LCD   | $V_{DD}-V_O$    | $T_a=-20^{\circ}\text{C}$ | —           | —    | 26.2        | V    |
|                          |                 | $T_a=25^{\circ}\text{C}$  | 23.0        | 23.6 | 24.2        | V    |
|                          |                 | $T_a=70^{\circ}\text{C}$  | 22.1        | —    | —           | V    |
| *Note                    |                 |                           |             |      |             |      |
| Input High Volt.         | $V_{IH}$        | —                         | $0.5V_{DD}$ | —    | $V_{DD}$    | V    |
| Input Low Volt.          | $V_{IL}$        | —                         | $V_{SS}$    | —    | $0.2V_{DD}$ | V    |
| Output High Volt.        | $V_{OH}$        | —                         | 2.4         | —    | —           | V    |
| Output Low Volt.         | $V_{OL}$        | —                         | —           | —    | 0.4         | V    |
| Supply Current           | $I_{DD}$        | $V_{DD}=5.0\text{V}$      | 35.0        | 65.0 | 110.0       | mA   |

\* Note: Please design the VOP adjustment circuit on customer's main board

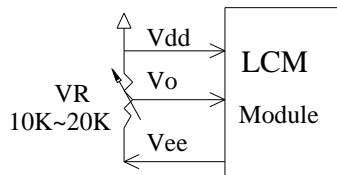

# 6. Optical Characteristics

| Item           | Symbol   | Condition   | Min | Typ | Max | Unit               |
|----------------|----------|-------------|-----|-----|-----|--------------------|
| View Angle     | $\theta$ | $CR \geq 2$ | 0   | —   | 20  | $\psi = 180^\circ$ |
|                | $\theta$ | $CR \geq 2$ | 0   | —   | 40  | $\psi = 0^\circ$   |
|                | $\theta$ | $CR \geq 2$ | 0   | —   | 30  | $\psi = 90^\circ$  |
|                | $\theta$ | $CR \geq 2$ | 0   | —   | 30  | $\psi = 270^\circ$ |
| Contrast Ratio | CR       | —           | —   | 3   | —   | —                  |
| Response Time  | T rise   | —           | —   | 200 | 300 | ms                 |
|                | T fall   | —           | —   | 250 | 350 | ms                 |

**Definition of Operation Voltage (Vop)**

**Definition of Response Time (Tr, Tf)**

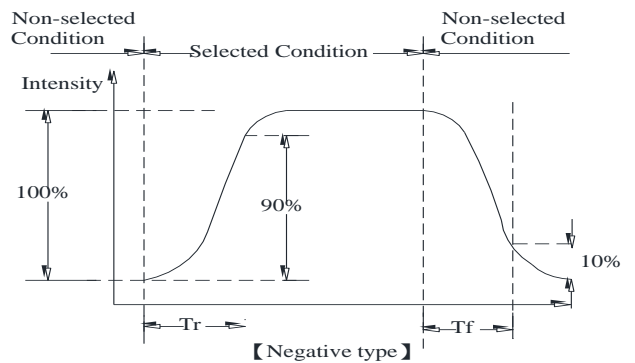
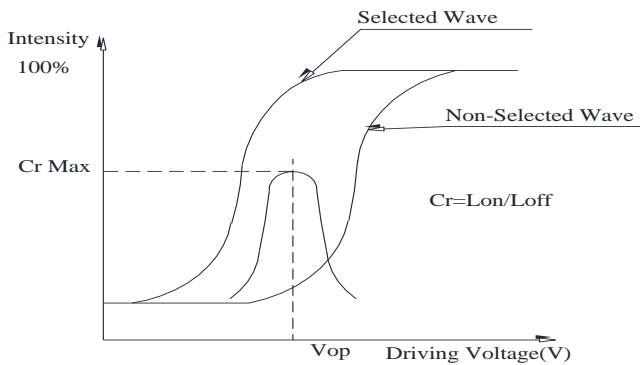
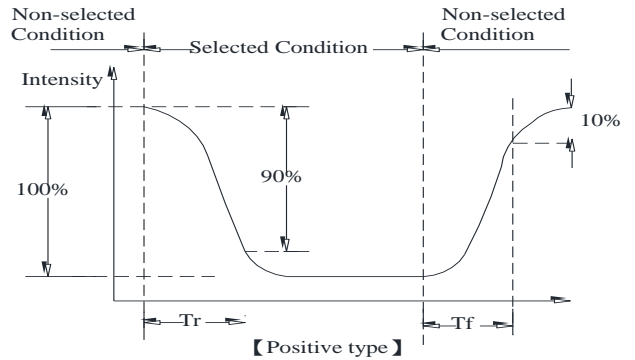
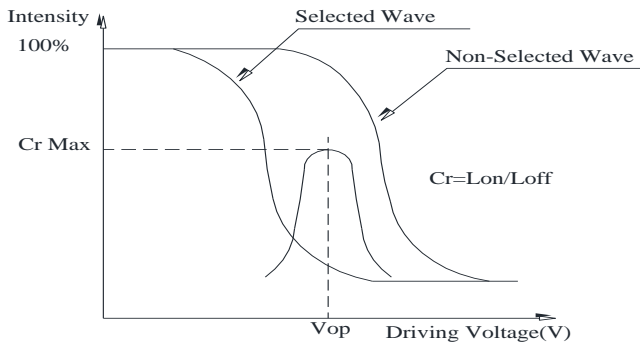

**Conditions :**

Operating Voltage : Vop      Viewing Angle( $\theta$  ,  $\phi$ ) :  $0^\circ$  ,  $0^\circ$   
 Frame Frequency : 64 HZ      Driving Waveform : 1/N duty , 1/a bias

**Definition of viewing angle( $CR \geq 2$ )**

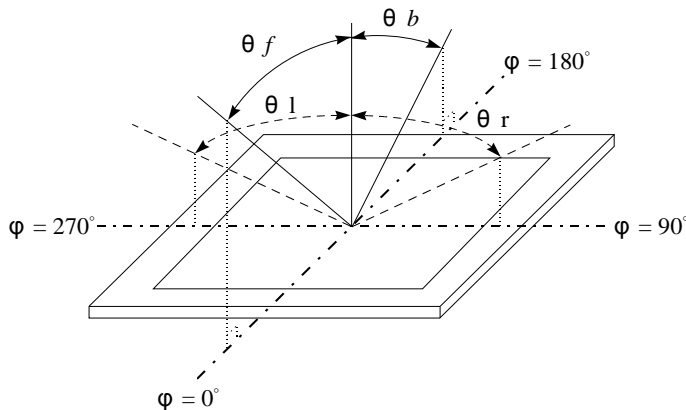

# 7.Interface Pin Function

## 8080 family

| Pin No. | Symbol  | Level      | Description   |
|---------|---------|------------|---|
| 1       | VSS     | 0V         | Ground  |
| 2       | VDD     | 5.0V       | Power supply for Logic                              |
| 3       | VO      | (Variable) | Driving voltage for LCD                             |
| 4       | A0      | H/L        | Data type select                                    |
| 5       | /WR     | H/L        | 8080 family: Write signal, 6800 family: R/W signal  |
| 6       | /RD     | H/L        | 8080 family: Read signal, 6800 family: Enable clock |
| 7~14    | DB0~DB7 | H/L        | Data bus line                                       |
| 15      | /CS     | H/L        | Chip select ,Active L                               |
| 16      | /RES    | H/L        | Controller reset signal, Active L                   |
| 17      | Vee     |            | Negative Voltage Output                             |
| 18      | NC      |            | No connection                                       |
| 19      | FG      |            | Frame ground  |
| 20      | NC      |            | No connection                                       |

# 8. Contour Drawing & Block Diagram

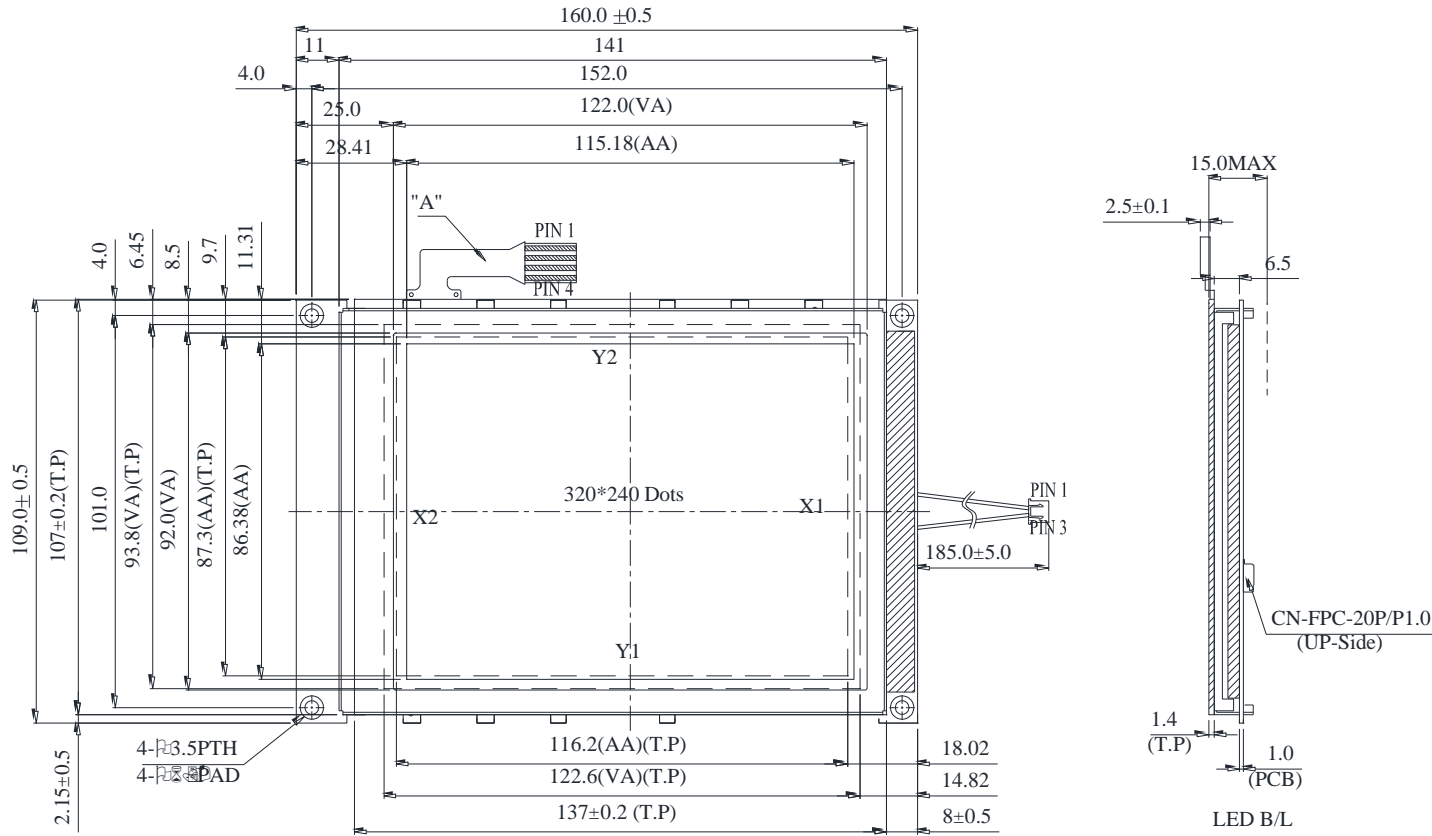

| PIN NO. | SYMBOL |
|---------|--------|
| 1       | Vss    |
| 2       | Vdd    |
| 3       | Vo     |
| 4       | A0     |
| 5       | WR     |
| 6       | RD     |
| 7       | DB0    |
| 8       | DB1    |
| 9       | DB2    |
| 10      | DB3    |
| 11      | DB4    |
| 12      | DB5    |
| 13      | DB6    |
| 14      | DB7    |
| 15      | CS     |
| 16      | RES    |
| 17      | Vee    |
| 18      | NC     |
| 19      | FG     |
| 20      | NC     |

| PIN NO. | Assignment |
|---------|------------|
| 1       | X2         |
| 2       | X1         |
| 3       | Y1         |
| 4       | Y2         |

TOUCH PANEL PIN ASSIGNMENT

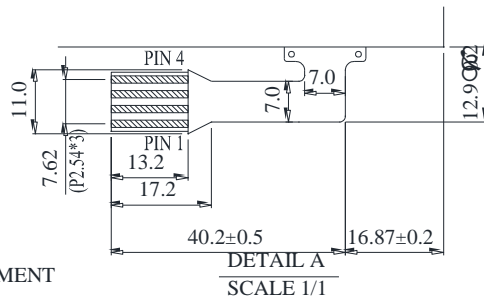

The non-specified tolerance of dimension is  $\pm 0.3\text{mm}$ .

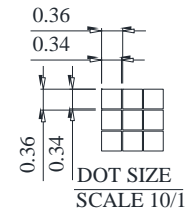

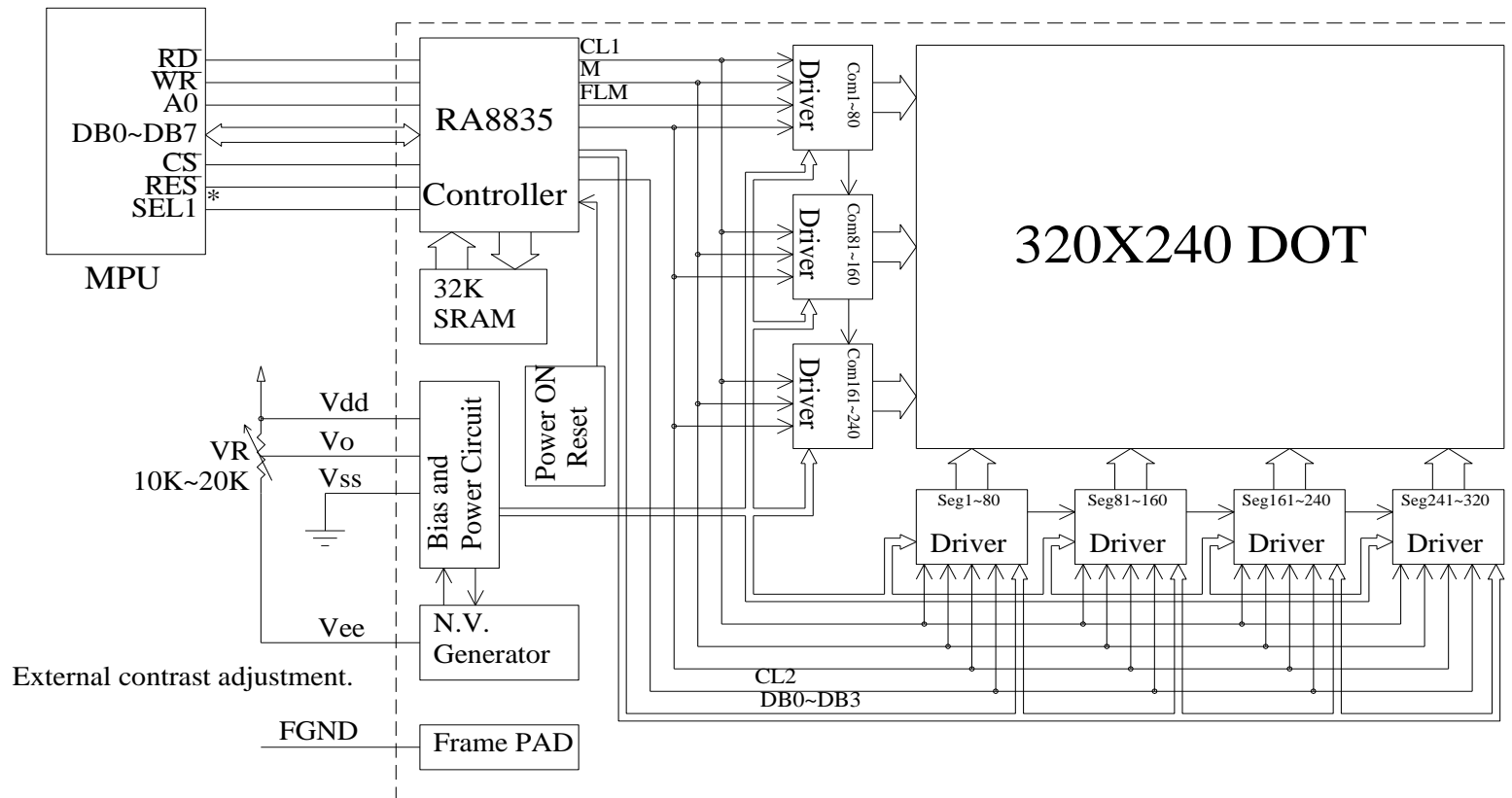

\*:6800 family or 8080family interface selectable.

# 9. Reliability

Content of Reliability Test (Wide temperature, -20°C~70°C)

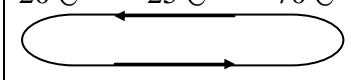
| Environmental Test                 |  |   |        |
|------------------------------------|--|---|--------|
| Test Item                          | Content of Test  | Test Condition  | Note   |
| High Temperature storage           | Endurance test applying the high storage temperature for a long time.  | 80°C<br>200hrs  | 2      |
| Low Temperature storage            | Endurance test applying the low storage temperature for a long time.   | -30°C<br>200hrs   | 1,2    |
| High Temperature Operation         | Endurance test applying the electric stress (Voltage & Current) and the thermal stress to the element for a long time.   | 70°C<br>200hrs  | —<br>— |
| Low Temperature Operation          | Endurance test applying the electric stress under low temperature for a long time.   | -20°C<br>200hrs   | 1      |
| High Temperature/ Humidity storage | The module should be allowed to stand at 60°C, 90%RH max<br>For 96hrs under no-load condition excluding the polarizer, Then taking it out and drying it at normal temperature.   | 60°C, 90%RH<br>96hrs  | 1,2    |
| Thermal shock resistance           | The sample should be allowed stand the following 10 cycles of operation<br>-20°C      25°C      70°C<br><br>30min    5min    30min<br>1 cycle | -20°C/70°C<br>10 cycles   | —<br>— |
| Vibration test                     | Endurance test applying the vibration during transportation and using.   | Total fixed amplitude : 1.5mm<br>Vibration Frequency : 10~55Hz<br>One cycle 60 seconds to 3 directions of X,Y,Z for Each 15 minutes | 3      |
| Static electricity test            | Endurance test applying the electric stress to the terminal.   | VS=±600V(contact),<br>±800v(air),<br>RS=330Ω<br>CS=150pF<br>10 times  | —<br>— |

**Note1: No dew condensation to be observed.**

**Note2: The function test shall be conducted after 4 hours storage at the normal Temperature and humidity after remove from the test chamber.**

**Note3: The packing have to including into the vibration testing.**

# 10. Backlight Information

## Specification

| PARAMETER                             | SYMBOL           | MIN | TYP | MAX | UNIT              | TEST CONDITION   |
|---------------------------------------|------------------|-----|-----|-----|-------------------|--|
| Supply Current                        | I <sub>LED</sub> | 40  | 128 | 160 | mA                | V=3.5V(Note 1)   |
| Supply Voltage                        | V                | 3.4 | 3.5 | 3.6 | V                 | —  |
| Reverse Voltage                       | V <sub>R</sub>   | —   | —   | 5   | V                 | —  |
| Luminance<br>(Without LCD)            | I <sub>V</sub>   | 380 | 420 | —   | CD/M <sup>2</sup> | I <sub>LED</sub> =128mA                                |
| LED Life Time<br>(For Reference only) | —                | —   | 50K | —   | Hr.               | I <sub>LED</sub> =128mA<br>25°C, 50-60%RH,<br>(Note 2) |
| Color                                 | White            |     |     |     |                   |  |

**Note:** The LED of B/L is drive by current only, drive voltage is for reference only. drive voltage can make driving current under safety area (current between minimum and maximum).

**Note 1:** Supply current minimum value is only for reference since LED brightness efficiency keeps enhancing. Current consumption becomes less and less to achieve the same luminance

**Note 2:** 50K hours is only an estimate for reference.

### LED B\L Drive Method

#### 1. Drive from A , K

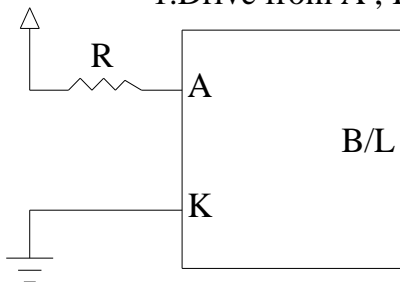

# 11.Touch panel Information

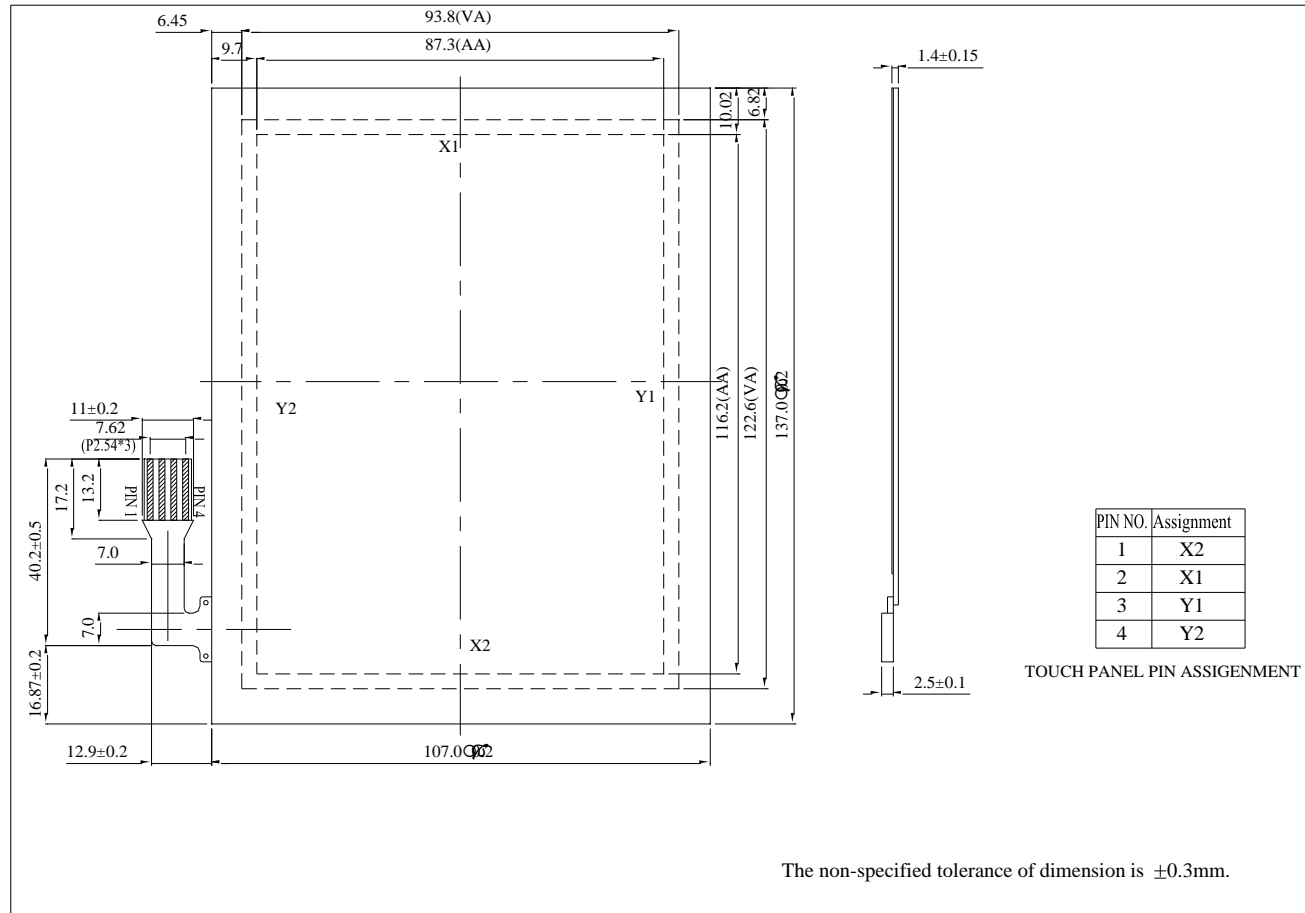

## Non-Proper Ways to handle the touch screen

1. Do not pull or crease the tail of the touch screen.
2. Tails, unless the drawing calls out for a bend, are to be free of permanent creases in the polyester, slight crease lines in the adhesive tail cover are allowed.

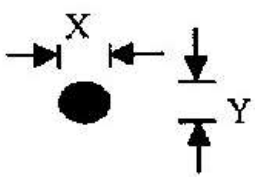
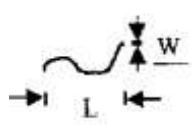

# 12. Inspection specification

| NO   | Item  | Criterion   | AQL             |                 |                  |                 |                         |                      |                         |              |                      |     |            |               |     |
|--|---|---|-----------------|-----------------|------------------|-----------------|-------------------------|----------------------|-------------------------|--------------|----------------------|-----|------------|---------------|-----|
| 01   | Electrical Testing  | <p>Missing vertical, horizontal segment, segment contrast defect.</p> <p>Missing character , dot or icon.</p> <p>Display malfunction.</p> <p>No function or no display.</p> <p>Current consumption exceeds product specifications.</p> <p>LCD viewing angle defect.</p> <p>Mixed product types.</p> <p>Contrast defect.</p>   | 0.65            |                 |                  |                 |                         |                      |                         |              |                      |     |            |               |     |
| 02   | Black or white spots on LCD (display only)                | <p>2.1 White and black spots on display <math>\leq 0.25\text{mm}</math>, no more than three white or black spots present.</p> <p>2.2 Densely spaced: No more than two spots or lines within 3mm</p>   | 2.5             |                 |                  |                 |                         |                      |                         |              |                      |     |            |               |     |
| 03   | LCD black spots, white spots, contamination (non-display) | <p>3.1 Round type : As following drawing</p> <p><math>\Phi = (x + y) / 2</math></p>  <table border="1" data-bbox="805 981 1332 1236"> <thead> <tr> <th>SIZE</th> <th>Acceptable Q TY</th> </tr> </thead> <tbody> <tr> <td><math>\Phi \leq 0.10</math></td> <td>Accept no dense</td> </tr> <tr> <td><math>0.10 &lt; \Phi \leq 0.20</math></td> <td>2</td> </tr> <tr> <td><math>0.20 &lt; \Phi \leq 0.25</math></td> <td>1</td> </tr> <tr> <td><math>0.25 &lt; \Phi</math></td> <td>0</td> </tr> </tbody> </table>               | SIZE            | Acceptable Q TY | $\Phi \leq 0.10$ | Accept no dense | $0.10 < \Phi \leq 0.20$ | 2                    | $0.20 < \Phi \leq 0.25$ | 1            | $0.25 < \Phi$        | 0   | 2.5        |               |     |
|  |   | SIZE  | Acceptable Q TY |                 |                  |                 |                         |                      |                         |              |                      |     |            |               |     |
| $\Phi \leq 0.10$   | Accept no dense   |   |                 |                 |                  |                 |                         |                      |                         |              |                      |     |            |               |     |
| $0.10 < \Phi \leq 0.20$  | 2   |   |                 |                 |                  |                 |                         |                      |                         |              |                      |     |            |               |     |
| $0.20 < \Phi \leq 0.25$  | 1   |   |                 |                 |                  |                 |                         |                      |                         |              |                      |     |            |               |     |
| $0.25 < \Phi$  | 0   |   |                 |                 |                  |                 |                         |                      |                         |              |                      |     |            |               |     |
| <p>3.2 Line type : (As following drawing)</p>  <table border="1" data-bbox="694 1328 1332 1579"> <thead> <tr> <th>Length</th> <th>Width</th> <th>Acceptable Q TY</th> </tr> </thead> <tbody> <tr> <td>---</td> <td><math>W \leq 0.02</math></td> <td>Accept no dense</td> </tr> <tr> <td><math>L \leq 3.0</math></td> <td><math>0.02 &lt; W \leq 0.03</math></td> <td rowspan="2">2</td> </tr> <tr> <td><math>L \leq 2.5</math></td> <td><math>0.03 &lt; W \leq 0.05</math></td> </tr> <tr> <td>---</td> <td><math>0.05 &lt; W</math></td> <td>As round type</td> </tr> </tbody> </table> | Length  | Width   | Acceptable Q TY | ---             | $W \leq 0.02$    | Accept no dense | $L \leq 3.0$            | $0.02 < W \leq 0.03$ | 2                       | $L \leq 2.5$ | $0.03 < W \leq 0.05$ | --- | $0.05 < W$ | As round type | 2.5 |
| Length   | Width   | Acceptable Q TY   |                 |                 |                  |                 |                         |                      |                         |              |                      |     |            |               |     |
| ---  | $W \leq 0.02$   | Accept no dense   |                 |                 |                  |                 |                         |                      |                         |              |                      |     |            |               |     |
| $L \leq 3.0$   | $0.02 < W \leq 0.03$                                      | 2   |                 |                 |                  |                 |                         |                      |                         |              |                      |     |            |               |     |
| $L \leq 2.5$   | $0.03 < W \leq 0.05$                                      |   |                 |                 |                  |                 |                         |                      |                         |              |                      |     |            |               |     |
| ---  | $0.05 < W$  | As round type   |                 |                 |                  |                 |                         |                      |                         |              |                      |     |            |               |     |
| 04   | Polarizer bubbles   | <p>If bubbles are visible, judge using black spot specifications, not easy to find, must check in specify direction.</p> <table border="1" data-bbox="826 1706 1332 2004"> <thead> <tr> <th>Size <math>\Phi</math></th> <th>Acceptable Q TY</th> </tr> </thead> <tbody> <tr> <td><math>\Phi \leq 0.20</math></td> <td>Accept no dense</td> </tr> <tr> <td><math>0.20 &lt; \Phi \leq 0.50</math></td> <td>3</td> </tr> <tr> <td><math>0.50 &lt; \Phi \leq 1.00</math></td> <td>2</td> </tr> <tr> <td><math>1.00 &lt; \Phi</math></td> <td>0</td> </tr> <tr> <td>Total Q TY</td> <td>3</td> </tr> </tbody> </table> | Size $\Phi$     | Acceptable Q TY | $\Phi \leq 0.20$ | Accept no dense | $0.20 < \Phi \leq 0.50$ | 3                    | $0.50 < \Phi \leq 1.00$ | 2            | $1.00 < \Phi$        | 0   | Total Q TY | 3             | 2.5 |
| Size $\Phi$  | Acceptable Q TY   |   |                 |                 |                  |                 |                         |                      |                         |              |                      |     |            |               |     |
| $\Phi \leq 0.20$   | Accept no dense   |   |                 |                 |                  |                 |                         |                      |                         |              |                      |     |            |               |     |
| $0.20 < \Phi \leq 0.50$  | 3   |   |                 |                 |                  |                 |                         |                      |                         |              |                      |     |            |               |     |
| $0.50 < \Phi \leq 1.00$  | 2   |   |                 |                 |                  |                 |                         |                      |                         |              |                      |     |            |               |     |
| $1.00 < \Phi$  | 0   |   |                 |                 |                  |                 |                         |                      |                         |              |                      |     |            |               |     |
| Total Q TY   | 3   |   |                 |                 |                  |                 |                         |                      |                         |              |                      |     |            |               |     |

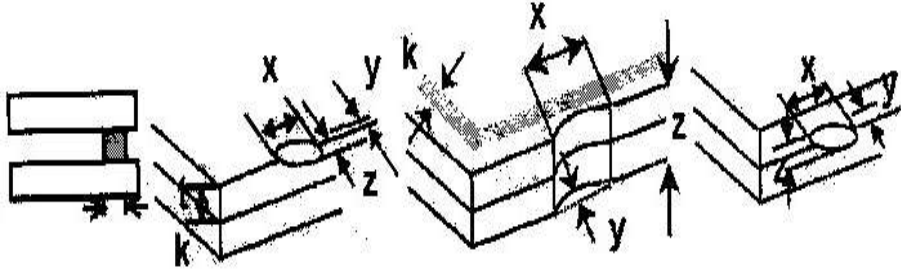
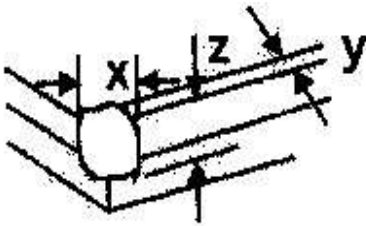
| NO                 | Item                  | Criterion   | AQL               |               |                |               |                       |               |                    |                 |               |                   |               |                |               |                       |               |                    |                 |               |     |
|--------------------|-----------------------|---|-------------------|---------------|----------------|---------------|-----------------------|---------------|--------------------|-----------------|---------------|-------------------|---------------|----------------|---------------|-----------------------|---------------|--------------------|-----------------|---------------|-----|
| 05                 | Scratches             | Follow NO.3 LCD black spots, white spots, contamination   |                   |               |                |               |                       |               |                    |                 |               |                   |               |                |               |                       |               |                    |                 |               |     |
| 06                 | Chipped glass         | <p>Symbols Define:<br/> x: Chip length      y: Chip width      z: Chip thickness<br/> k: Seal width      t: Glass thickness      a: LCD side length<br/> L: Electrode pad length:</p> <p>6.1 General glass chip :<br/> 6.1.1 Chip on panel surface and crack between panels:</p>  <table border="1" data-bbox="443 884 1353 1093"> <thead> <tr> <th>z: Chip thickness</th> <th>y: Chip width</th> <th>x: Chip length</th> </tr> </thead> <tbody> <tr> <td><math>Z \leq 1/2t</math></td> <td>Not over viewing area</td> <td><math>x \leq 1/8a</math></td> </tr> <tr> <td><math>1/2t &lt; z \leq 2t</math></td> <td>Not exceed 1/3k</td> <td><math>x \leq 1/8a</math></td> </tr> </tbody> </table> <p>⊙If there are 2 or more chips, x is total length of each chip.</p> <p>6.1.2 Corner crack:</p>  <table border="1" data-bbox="443 1523 1353 1731"> <thead> <tr> <th>z: Chip thickness</th> <th>y: Chip width</th> <th>x: Chip length</th> </tr> </thead> <tbody> <tr> <td><math>Z \leq 1/2t</math></td> <td>Not over viewing area</td> <td><math>x \leq 1/8a</math></td> </tr> <tr> <td><math>1/2t &lt; z \leq 2t</math></td> <td>Not exceed 1/3k</td> <td><math>x \leq 1/8a</math></td> </tr> </tbody> </table> <p>⊙If there are 2 or more chips, x is the total length of each chip.</p> | z: Chip thickness | y: Chip width | x: Chip length | $Z \leq 1/2t$ | Not over viewing area | $x \leq 1/8a$ | $1/2t < z \leq 2t$ | Not exceed 1/3k | $x \leq 1/8a$ | z: Chip thickness | y: Chip width | x: Chip length | $Z \leq 1/2t$ | Not over viewing area | $x \leq 1/8a$ | $1/2t < z \leq 2t$ | Not exceed 1/3k | $x \leq 1/8a$ | 2.5 |
| z: Chip thickness  | y: Chip width         | x: Chip length  |                   |               |                |               |                       |               |                    |                 |               |                   |               |                |               |                       |               |                    |                 |               |     |
| $Z \leq 1/2t$      | Not over viewing area | $x \leq 1/8a$   |                   |               |                |               |                       |               |                    |                 |               |                   |               |                |               |                       |               |                    |                 |               |     |
| $1/2t < z \leq 2t$ | Not exceed 1/3k       | $x \leq 1/8a$   |                   |               |                |               |                       |               |                    |                 |               |                   |               |                |               |                       |               |                    |                 |               |     |
| z: Chip thickness  | y: Chip width         | x: Chip length  |                   |               |                |               |                       |               |                    |                 |               |                   |               |                |               |                       |               |                    |                 |               |     |
| $Z \leq 1/2t$      | Not over viewing area | $x \leq 1/8a$   |                   |               |                |               |                       |               |                    |                 |               |                   |               |                |               |                       |               |                    |                 |               |     |
| $1/2t < z \leq 2t$ | Not exceed 1/3k       | $x \leq 1/8a$   |                   |               |                |               |                       |               |                    |                 |               |                   |               |                |               |                       |               |                    |                 |               |     |

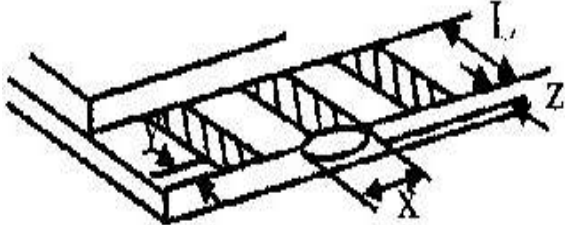
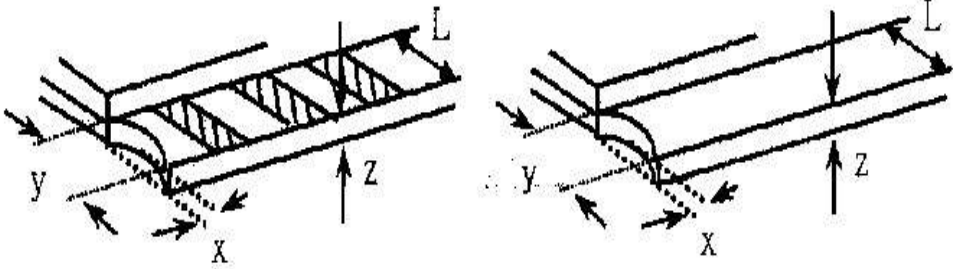
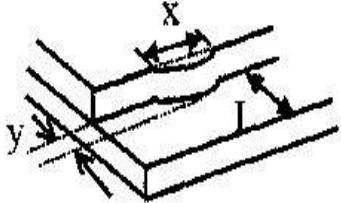
| NO                    | Item           | Criterion  | AQL           |                |                   |                       |               |                |               |                |                   |            |               |                |          |           |               |            |     |
|-----------------------|----------------|--|---------------|----------------|-------------------|-----------------------|---------------|----------------|---------------|----------------|-------------------|------------|---------------|----------------|----------|-----------|---------------|------------|-----|
| 06                    | Glass crack    | <p>Symbols :</p> <p>x: Chip length      y: Chip width      z: Chip thickness<br/> k: Seal width      t: Glass thickness      a: LCD side length<br/> L: Electrode pad length</p> <p>6.2 Protrusion over terminal :</p> <p>6.2.1 Chip on electrode pad :</p>  <table border="1" data-bbox="352 763 1275 864"> <tr> <td>y: Chip width</td> <td>x: Chip length</td> <td>z: Chip thickness</td> </tr> <tr> <td><math>y \leq 0.5\text{mm}</math></td> <td><math>x \leq 1/8a</math></td> <td><math>0 &lt; z \leq t</math></td> </tr> </table> <p>6.2.2 Non-conductive portion:</p>  <table border="1" data-bbox="424 1245 1251 1361"> <tr> <td>y: Chip width</td> <td>x: Chip length</td> <td>z: Chip thickness</td> </tr> <tr> <td><math>y \leq L</math></td> <td><math>x \leq 1/8a</math></td> <td><math>0 &lt; z \leq t</math></td> </tr> </table> <p>⊙ If the chipped area touches the ITO terminal, over 2/3 of the ITO must remain and be inspected according to electrode terminal specifications.<br/> ⊙ If the product will be heat sealed by the customer, the alignment mark not be damaged.</p> <p>6.2.3 Substrate protuberance and internal crack.</p>  <table border="1" data-bbox="762 1615 1323 1715"> <tr> <td>y: width</td> <td>x: length</td> </tr> <tr> <td><math>y \leq 1/3L</math></td> <td><math>x \leq a</math></td> </tr> </table> | y: Chip width | x: Chip length | z: Chip thickness | $y \leq 0.5\text{mm}$ | $x \leq 1/8a$ | $0 < z \leq t$ | y: Chip width | x: Chip length | z: Chip thickness | $y \leq L$ | $x \leq 1/8a$ | $0 < z \leq t$ | y: width | x: length | $y \leq 1/3L$ | $x \leq a$ | 2.5 |
| y: Chip width         | x: Chip length | z: Chip thickness  |               |                |                   |                       |               |                |               |                |                   |            |               |                |          |           |               |            |     |
| $y \leq 0.5\text{mm}$ | $x \leq 1/8a$  | $0 < z \leq t$   |               |                |                   |                       |               |                |               |                |                   |            |               |                |          |           |               |            |     |
| y: Chip width         | x: Chip length | z: Chip thickness  |               |                |                   |                       |               |                |               |                |                   |            |               |                |          |           |               |            |     |
| $y \leq L$            | $x \leq 1/8a$  | $0 < z \leq t$   |               |                |                   |                       |               |                |               |                |                   |            |               |                |          |           |               |            |     |
| y: width              | x: length      |  |               |                |                   |                       |               |                |               |                |                   |            |               |                |          |           |               |            |     |
| $y \leq 1/3L$         | $x \leq a$     |  |               |                |                   |                       |               |                |               |                |                   |            |               |                |          |           |               |            |     |

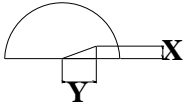
| NO | Item               | Criterion  | AQL   |
|----|--------------------|--|---|
| 07 | Cracked glass      | The LCD with extensive crack is not acceptable.  | 2.5   |
| 08 | Backlight elements | 8.1 Illumination source flickers when lit.<br>8.2 Spots or scratched that appear when lit must be judged. Using LCD spot, lines and contamination standards.<br>8.3 Backlight doesn't light or color wrong.  | 0.65<br>2.5<br>0.65   |
| 09 | Bezel              | 9.1 Bezel may not have rust, be deformed or have fingerprints, stains or other contamination.<br>9.2 Bezel must comply with job specifications.  | 2.5<br>0.65   |
| 10 | PCB、COB            | 10.1 COB seal may not have pinholes larger than 0.2mm or contamination.<br>10.2 COB seal surface may not have pinholes through to the IC.<br>10.3 The height of the COB should not exceed the height indicated in the assembly diagram.<br>10.4 There may not be more than 2mm of sealant outside the seal area on the PCB. And there should be no more than three places.<br>10.5 No oxidation or contamination PCB terminals.<br>10.6 Parts on PCB must be the same as on the production characteristic chart. There should be no wrong parts, missing parts or excess parts.<br>10.7 The jumper on the PCB should conform to the product characteristic chart.<br>10.8 If solder gets on bezel tab pads, LED pad, zebra pad or screw hold pad, make sure it is smoothed down.<br>10.9 The Scraping testing standard for Copper Coating of PCB<br><br>$X * Y \leq 2\text{mm}^2$ | 2.5<br>2.5<br>0.65<br>2.5<br>2.5<br>0.65<br>2.5<br>2.5<br>2.5 |
| 11 | Soldering          | 11.1 No un-melted solder paste may be present on the PCB.<br>11.2 No cold solder joints, missing solder connections, oxidation or icicle.<br>11.3 No residue or solder balls on PCB.<br>11.4 No short circuits in components on PCB.   | 2.5<br>2.5<br>2.5<br>0.65                                     |

| NO | Item               | Criterion   | AQL  |
|----|--------------------|---|------|
| 12 | General appearance | 12.1 No oxidation, contamination, curves or, bends on interface Pin (OLB) of TCP.   | 2.5  |
|    |                    | 12.2 No cracks on interface pin (OLB) of TCP.   | 0.65 |
|    |                    | 12.3 No contamination, solder residue or solder balls on product.   | 2.5  |
|    |                    | 12.4 The IC on the TCP may not be damaged, circuits.  | 2.5  |
|    |                    | 12.5 The uppermost edge of the protective strip on the interface pin must be present or look as if it cause the interface pin to sever. | 2.5  |
|    |                    | 12.6 The residual rosin or tin oil of soldering (component or chip component) is not burned into brown or black color.                  | 2.5  |
|    |                    | 12.7 Sealant on top of the ITO circuit has not hardened.  | 2.5  |
|    |                    | 12.8 Pin type must match type in specification sheet.   | 0.65 |
|    |                    | 12.9 LCD pin loose or missing pins.   | 0.65 |
|    |                    | 12.10 Product packaging must the same as specified on packaging specification sheet.  | 0.65 |
|    |                    | 12.11 Product dimension and structure must conform to product specification sheet.  | 0.65 |
|    |                    | 12.12 Visual defect outside of VA is not considered to be rejection.  | 0.65 |

# 13. Material List of Components for RoHs

1. WINSTAR Display Co., Ltd hereby declares that all of or part of products (with the mark “#”in code), including, but not limited to, the LCM, accessories or packages, manufactured and/or delivered to your company (including your subsidiaries and affiliated company) directly or indirectly by our company (including our subsidiaries or affiliated companies) do not intentionally contain any of the substances listed in all applicable EU directives and regulations, including the following substances.

Exhibit A : The Harmful Material List

| Material   | Cd      | Pb       | Hg       | Cr6+     | PBB      | PBDE     | DEHP     | BBP      | DBP      | DIBP     |
|--|---------|----------|----------|----------|----------|----------|----------|----------|----------|----------|
| Limited Value                                    | 100 ppm | 1000 ppm | 1000 ppm | 1000 ppm | 1000 ppm | 1000 ppm | 1000 ppm | 1000 ppm | 1000 ppm | 1000 ppm |
| Above limited value is set up according to RoHS. |         |          |          |          |          |          |          |          |          |          |

## 2. Process for RoHS requirement : (only for RoHS inspection)

- (1) Use the Sn/Ag/Cu soldering surface ; the surface of Pb-free solder is rougher than we used before.
- (2) Heat-resistance temp. :
  - Reflow : 250°C, 30 seconds Max. ;
  - Connector soldering wave or hand soldering : 320°C, 10 seconds max.
- (3) Temp. curve of reflow, max. Temp. : 235±5°C ;
  - Recommended customer’s soldering temp. of connector : 280°C, 3 seconds.

# **14.Recommendable Storage**

1. Place the panel or module in the temperature  $25^{\circ}\text{C}\pm 5^{\circ}\text{C}$  and the humidity below 65% RH
2. Do not place the module near organics solvents or corrosive gases.
3. Do not crush, shake, or jolt the module.



Module Number : \_\_\_\_\_

Page: 1

**1、Panel Specification :**

1. Panel Type :  Pass  NG , \_\_\_\_\_
2. View Direction :  Pass  NG , \_\_\_\_\_
3. Numbers of Dots :  Pass  NG , \_\_\_\_\_
4. View Area :  Pass  NG , \_\_\_\_\_
5. Active Area :  Pass  NG , \_\_\_\_\_
6. Operating Temperature :  Pass  NG , \_\_\_\_\_
7. Storage Temperature :  Pass  NG , \_\_\_\_\_
8. Others : \_\_\_\_\_

**2、Mechanical Specification :**

1. PCB Size :  Pass  NG , \_\_\_\_\_
2. Frame Size :  Pass  NG , \_\_\_\_\_
3. Material of Frame :  Pass  NG , \_\_\_\_\_
4. Connector Position :  Pass  NG , \_\_\_\_\_
5. Fix Hole Position :  Pass  NG , \_\_\_\_\_
6. Backlight Position :  Pass  NG , \_\_\_\_\_
7. Thickness of PCB :  Pass  NG , \_\_\_\_\_
8. Height of Frame to PCB :  Pass  NG , \_\_\_\_\_
9. Height of Module :  Pass  NG , \_\_\_\_\_
10. Others :  Pass  NG , \_\_\_\_\_

**3、Relative Hole Size :**

1. Pitch of Connector :  Pass  NG , \_\_\_\_\_
2. Hole size of Connector :  Pass  NG , \_\_\_\_\_
3. Mounting Hole size :  Pass  NG , \_\_\_\_\_
4. Mounting Hole Type :  Pass  NG , \_\_\_\_\_
5. Others :  Pass  NG , \_\_\_\_\_

**4、Backlight Specification :**

1. B/L Type :  Pass  NG , \_\_\_\_\_
2. B/L Color :  Pass  NG , \_\_\_\_\_
3. B/L Driving Voltage (Reference for LED Type) :  Pass  NG , \_\_\_\_\_
4. B/L Driving Current :  Pass  NG , \_\_\_\_\_
5. Brightness of B/L :  Pass  NG , \_\_\_\_\_
6. B/L Solder Method :  Pass  NG , \_\_\_\_\_
7. Others :  Pass  NG , \_\_\_\_\_

>> **Go to page 2** <<



**5、Electronic Characteristics of Module :**

- |                              |                               |                                     |
|------------------------------|-------------------------------|-------------------------------------|
| 1. Input Voltage :           | <input type="checkbox"/> Pass | <input type="checkbox"/> NG , _____ |
| 2. Supply Current :          | <input type="checkbox"/> Pass | <input type="checkbox"/> NG , _____ |
| 3. Driving Voltage for LCD : | <input type="checkbox"/> Pass | <input type="checkbox"/> NG , _____ |
| 4. Contrast for LCD :        | <input type="checkbox"/> Pass | <input type="checkbox"/> NG , _____ |
| 5. B/L Driving Method :      | <input type="checkbox"/> Pass | <input type="checkbox"/> NG , _____ |
| 6. Negative Voltage Output : | <input type="checkbox"/> Pass | <input type="checkbox"/> NG , _____ |
| 7. Interface Function :      | <input type="checkbox"/> Pass | <input type="checkbox"/> NG , _____ |
| 8. LCD Uniformity :          | <input type="checkbox"/> Pass | <input type="checkbox"/> NG , _____ |
| 9. ESD test :                | <input type="checkbox"/> Pass | <input type="checkbox"/> NG , _____ |
| 10. Others :                 | <input type="checkbox"/> Pass | <input type="checkbox"/> NG , _____ |

**6、Summary :**

Sales signature : \_\_\_\_\_

Customer Signature : \_\_\_\_\_

Date :    /    /