



**健隆投資有限公司**  
**STRONG BASE INVESTMENT LTD.**

Unit 17, 11/F., Hewlett Centre, 52-54 Hoi Yuen Road, Kwun Tong, Kowloon, Hong Kong.  
Tel: (852) 2793 3293 Fax: (852) 2793 3096



**Approval Sheet**  
**(確認書)**

<b>編號</b> Ref. No.	
<b>日期</b> Issued Date	2015-10-28

**公司名稱** : \_\_\_\_\_  
Company Name

**產品編號** : 2G52HD-28  
Part No.

**產品種類** : LED-LAMP  
Category

**產品描述** : 2\*5\*7MM/ HIGH BRIGHT GREEN , GREEN DIFFUSED  
Description

**客戶產品編號** : \_\_\_\_\_  
Customer No.

**備注** : \_\_\_\_\_  
Remarks

STRONG BASE			
ISSUER	APPROVER	CHECKER	ENGINEER
	朱美丽	叶楠	高雪

Authorized Signature 客戶簽字				
部門 Department				
簽字 Signature				

工廠名稱:宇之亮電子(深圳)有限公司  
工廠地址:廣東省深圳市龍崗區橫崗鎮荷坳村金源工業區  
Company Name: Pretty Light (Shen Zhen) Limited  
Factory Address:jin-Yuan,Industrial Zone He-Ao Cun,Heng-Gang  
Zhen Long-Gang Area,Shen-Zhen City,  
TEL: (755) 8976 6931 2862 5421 FAX: (755) 28684819 2862 5922

**PART NO. : 2G52HD-28**

**DATE : 3 February 2016**

2\*5\*7MM/ HIGH BRIGHT GREEN , GREEN DIFFUSE

**SPECIFICATION**

**ABSOLUTE MAXIMUM RATING (Ta=25°C)**

Item	Symbol	Rating	Unit
Power Dissipation	$P_{D(AVG)}$	80	mW
Forward Current	$I_F$	20	mA
Peak Forward Current (1/10 Duty Cycle, 0.1 ms Pulse Width)	$I_{FP}$	100	mA
Reverse Voltage	$V_R$	5	V
Operating Temperature	$T_{opr}$	-40~+80	°C
Storage Temperature	$T_{stg}$	-40~+80	°C

**ELECTRICAL/OPTICAL CHARACTERISTICS RATING (Ta=25°C)**

Item	Symbol	Test Conditions	Rating			Unit
			Min.	Typ.	Max.	
Forward Voltage	$V_F$	$I_F=20mA$	1.9	2.2	2.8	V
Reverse Current	$I_R$	$V_R=5V$	---	---	10	$\mu A$
Luminous Intensity	$I_V$	$I_F=20mA$	---	6	---	mcd
Dominant Wave Length	$\lambda_d$	$I_F=20mA$	---	570	--	nm
Viewing Angle $2\theta_{1/2}$	$2\theta_{1/2}$	$I_F=20mA$	140°			deg.

**Notes:-**

1)  $\theta_{1/2}$  is the off-axis angle where the luminous intensity is half the optical centerline value.

**Soldering Conditions** : Soldering Temp.  $\leq 260^\circ C$   
 Soldering Time  $\leq 5$  Sec.



**Caution** : **ESD** protection measures shall be considered and taken in the initial design stage, because static electricity and surge could damage the LED.  
 A wrist band or an anti-electrostatic glove should be used when handling **Electrostatic Sensitive Devices**.

**PART NO. : 2G52HD-28**

**DATE : 3 February 2016**

2\*5\*7MM/ HIGH BRIGHT GREEN , GREEN DIFFUSE

**PACKAGE DIMENSION**

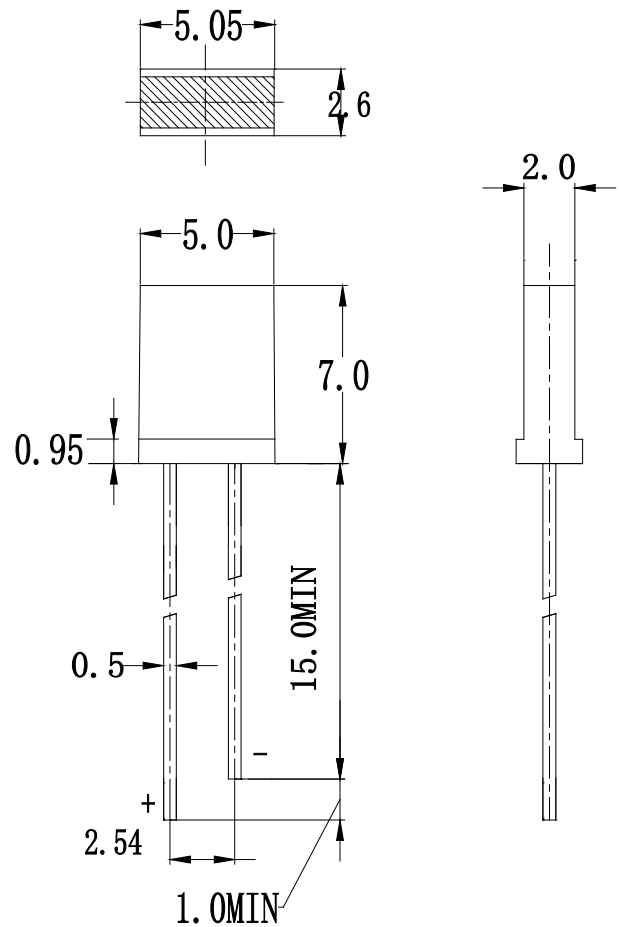
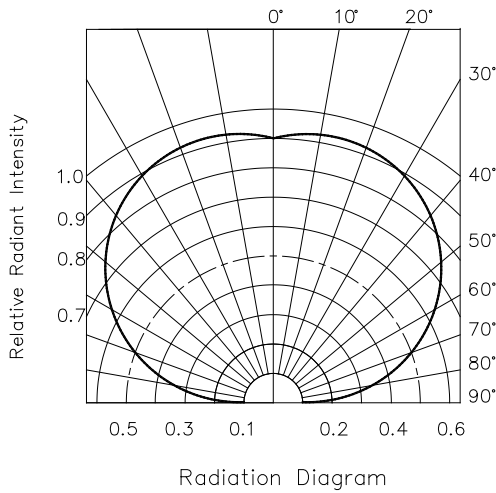

**Tolerance:  $\pm 0.25(0.01)$**   
**Unit: mm(inch)**

Item	Materials
Resin(Mold)	Epoxy Resin
Lead Frame	Copper Alloy

Part Number	Emitting Color	Lens Type
2G52HD-28	GREEN	GREEN DIFFUSED

**PART NO. : 2G52HD-28**

**DATE : 3 February 2016**

2\*5\*7MM/ HIGH BRIGHT GREEN , GREEN DIFFUSE

**Typical Electrical/Optical Characteristics Curves**

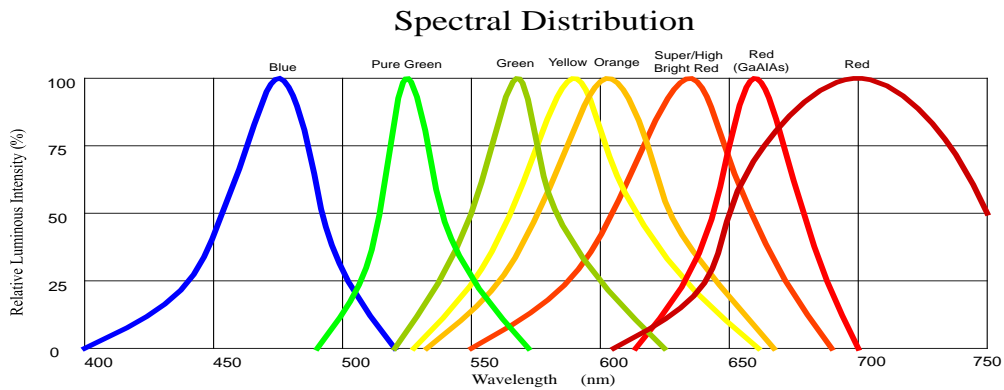

(25°C) Ambient Temperature Unless Otherwise Noted

