



No	APS-1607-011	Version	A/1
Date	2016.7.16	Page	Page 1 of 13
<b>Metallized Polypropylene Film Interference Suppression Capacitor (Class X1)</b>			

### Datasheet of Film Capacitor W45

Customer	
----------	--

WEIDY PART NO	Product specification	CUSTOMER'S PART NO.
W45S1334KQ8L001GW0	MKP65-440VAC-334K-P22.5	

Seller	
Approval	
Date	9/19/2024
Ratify	Yi Zhang
Audit	Yi Zhang
Maker	Lili Li

Buyer	
Approval	
Date	
Ratify	
Title	
Remark	Pls send copy to us after approval

### Company Information

Company name: Shenzhen Weidy Industrial Development Co.,Ltd  
Company Address : 5/F, New Asia Electronic Town, Zhenzhong Rd, Futian, Shenzhen, Guangdong, China.  
TEL:0755-82811688 FAX: 0755-82812688 <http://www.weidy.net>  
Factory Address: No8,Songyin Rd., Pingshan Community, Tangxia





No	APS-1607-011	Version	A/1
Date	2016.7.16	Page	Page 4 of 13
<b>Metallized Polypropylene Film Interference Suppression Capacitor (Class X1)</b>			

❖ **Part number system**  
For example:

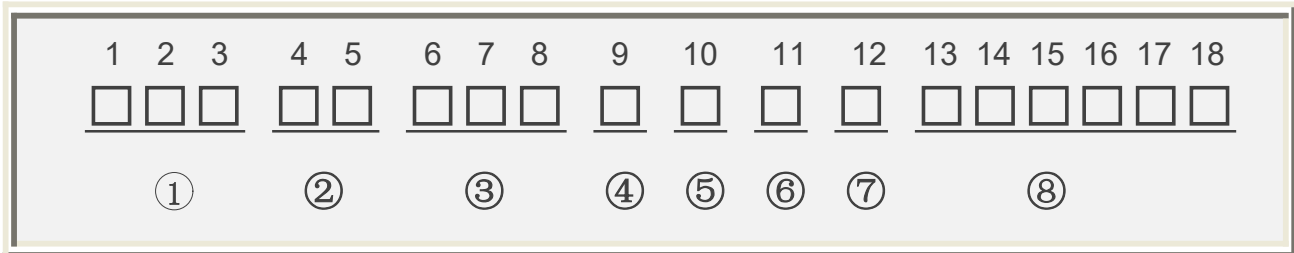

① **Series code(Digit 1 to 3)**

Series	CH11	CL11	CBB11	CBB13	CBB81	CBB81 B	WDQB	WDQC	PSR	CL20 T	CL21	CL21X
Code	W10	W11	W12	W13	W14	W15	W16	W17	W18	W20	W21	W22
Series	CL21B	CL23B	CL25	CL20A	CBB20T	CBB21	CBB21B	CBB20A	MKP25	CBB2 2	MKPR S	MKPE (X2(E))
Code	W23	W24	W25	W26	W30	W31	W32	W33	W38	W36	W40	W41
Series	MKP (X2)	MKP63 (Y2)	MKP64 (X1)	MKP65 (X1/440V)	MKP66 (X1/760V)	CL21B (E)	CBB21B (E)	CBB21(E)	CLN51	CBS5 2	CBB60	CBB61
Code	W42	W43	W44	W45	W46	W47	W48	W49	W51	W52	W60	W61
Series	CBB65	CBB71	CBB72	MMKP82	MMKP84	CLN21	C92	CBB13B	CBB62	RCP	CBB28	CL21 (E)
Code	W65	W71	W72	W82	W84	W91	W92	W19	W62	W39	W28	W50
Series	CBB22 (E)	X1Y2	CL21S	CBB21S	MKP23	MKPR						
Code	W53	W54	W27	W37	W29	W63						

② **Rated Voltage(Digit 4-5)** (Remark: number and then letter indicate DC, letter and then number indicate AC)

	A	B	C	D	E	F	G	H	J	K	L	M	N
1			16V	20V	25V			50V	63V	80V			
2	100V	125V	160V	200V	250V		400V	500V	630V	800V	230V	120V	150V
3	1000V	1250V	1600V	2000V	2500V	3000V	4000V			850V		1200V	1500V
	P	Q	R	S	T	U	V	W	X	Y			
1	240V	300V	330V	440V	540V	600V	700V	1100V	900V				
2	275V	305V	350V	450V	550V	690V	760V	1300V					
3	280V	310V		480V	520V			1700V					

No	APS-1607-011	Version	A/1
Date	2016.7.16	Page	Page 5 of 13
<b>Metallized Polypropylene Film Interference Suppression Capacitor (Class X1)</b>			

### ③ Rated capacitance value(Digit 6 to 8)

According to JIS

101=10x10<sup>1</sup> pF=0.1nF      102=10x10<sup>2</sup> pF=1.0nF= 0.001uF      103=10x10<sup>3</sup>pF=10nF=0.01uF  
 104=10x10<sup>4</sup> pF=100nF=0.1uF      105=10x10<sup>5</sup> pF=1000nF=1uF      106=10x10<sup>6</sup> pF=10000nF=10Uf  
 107 =100uF      108 =1000uF      109 =10000uF

### ④ Capacitance tolerance (Digit 9)

Tolerance	± 1%	± 2%	± 3%	± 5%	±10%	±15%	± 20%	0~+10%	0~-10%		
Code	F	G	H	J	K	L	M	T	P		

### ⑤ Pitch/ Length of Axial products (Digit 10)

Pitch	3.5	4.0	4.5	5.0	5.5	6.0	6.5	7.0	7.5	10.0	12.5	15.0	20.0
Code	A	B	C	D	E	F	G	H	J	K	L	M	N
Pitch	22.0	22.5	25.0	27.0	27.5	30.0	31.0	32	37	26	8		
Code	P	Q	R	S	T	U	V	W	X	Y	1		
Pitch	15	19	21	27	32	37	42	46	24	50	56		
Code	1	2	3	4	5	6	7	8	9	A	B		

\*When the products are axial products, it stands for the length of the products

### ⑥ Lead (Digit 11)

Lead	CP 0.5	CP 0.6	CP 0.7	CP 0.8	CU 1.0	CU 0.8						
code	5	6	7	8	1	9						

### ⑦ Package type and code of Lead Configuration(Digit 12)

Code	Remarks
S	Straight leads, lead Cut (L≤8mm)
M	Straight leads, lead Cut (20mm>L>8mm)
L	Straight leads, lead Cut (L≥20mm)
W	Leads bent into 90 Degree
K	Forming lead(tolerance of lead length±0.5mm)
Y	Forming lead(tolerance of lead length±0.3mm)
T	Taping packing

### ⑧ Internal use ( Digit 13 ~ 18)

No	APS-1607-011	Version	A/1
Date	2016.7.16	Page	Page 6 of 13
<b>Metallized Polypropylene Film Interference Suppression Capacitor (Class X1)</b>			

## ✧ Features

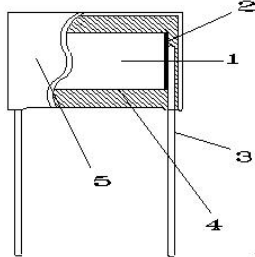
Product name	<b>Metallized Polypropylene Film Interference Suppression Capacitor (Class X1)</b>					
Reference Standard	(AEC-Q200) GB/T 2693 (IEC 60384-1) GB/T 6346 (IEC 60384-14)					
Construction				<ol style="list-style-type: none"> <li>1. Metallized polypropylene film</li> <li>2. Metal spray</li> <li>3. Lead wire</li> <li>4. (UL94V-0) Flame retardant Epoxy resin coating</li> <li>5. (UL94V-0) Flame retardant plastic box</li> </ol>		
Atmospheric conditions IEC 68-1	<p>Standard atmospheric conditions (IEC 68-1-5.3)</p> <p>Temperature : 15°C ~ 35°C</p> <p>Humidity: 25% ~ 75%</p> <p>Air pressure: 86KPa ~ 106KPa</p> <p style="text-align: right;">Base condition: (IEC 68-1-5.1)</p> <p style="text-align: right;">Temperature: 20°C</p> <p style="text-align: right;">Air pressure: 101.3KPa</p>					
Technology Specifications	<p>Climatic category: 40/110/56</p> <p>Capacitor series: X1</p> <p>Operating Temperature: -40°C ~ 110°C</p> <p>Rated Voltage: 440VAC</p> <p>Capacitance Range: 0.001μF ~ 10.0μF</p> <p>Capacitance Tolerance: ±10% (K)</p> <p>Voltage Proof: Between two leads 4.3U<sub>R</sub>(DC) (5S)</p> <p>Voltage Applied Speed: 100V/S; Cut off current: 10mA</p> <p style="text-align: center;">Between Terminals to Case: 2560VAC</p> <p>Dissipation Factor: 0.0010μF ≤ C<sub>R</sub> ≤ 1.0μF ≤ 0.15% (1kHz, 20°C)</p> <p style="text-align: center;">1.0μF &lt; C<sub>R</sub> ≤ 10μF ≤ 0.3% (1kHz, 20°C)</p> <p>Insulation Resistance: ≥ 15000MΩ ; C<sub>R</sub> ≤ 0.33μF</p> <p style="text-align: center;">≥ 5000S; C<sub>R</sub> &gt; 0.33μF (20°C, 100V, 1min)</p>					
Terminal Strength IEC 68-2-21 GB 14472-4.3	Tension	Dia. (mm)	Tension	Bend	Dia. (mm)	Tension
		0.3 < d ≤ 0.5	5N		0.3 < d ≤ 0.5	2.5N
		0.5 < d ≤ 0.8	10N		0.5 < d ≤ 0.8	5N
		0.8 < d ≤ 1.25	20N		0.8 < d ≤ 1.25	10N
	Time duration: 10 ± 1Sec.			Bending for twice in two direction		
	After above test, no visible damage.					

No	APS-1607-011	Version	A/1
Date	2016.7.16	Page	Page 7 of 13
<b>Metallized Polypropylene Film Interference Suppression Capacitor (Class X1)</b>			

Solder ability IEC 68-2-20	Soldering temperature: 235°C±5°C Immersion duration: 2.0s±0.5s Good Tinning		
Soldering heat IEC 68-2-20 GB 14472-4.4	Soldering temperature: 260°C±5°C Immersion duration: 10s±1s Dip depth from the mounting surface 2+0/-0.5mm, using the thickness of 1.5mm ± 0.5mm insulation shielding plate Capacitance change: $\Delta C/C : \leq \pm 5\%$		
Temperature Cycling IEC 68-2-14	Temperature: $\theta A = -40^{\circ}\text{C}$ ; $\theta B = +110^{\circ}\text{C}$ Time duration: 30min ; Cycling times: five times Capacitance change: $\Delta C/C : \leq \pm 5\%$		
Vibration IEC 68-2-6	Frequency: 10 ~ 500Hz Time and direction: Each of the three directions for two hours, total duration about 6 hours Amplitude 0.75mm Or acceleration 98m/s <sup>2</sup> (Taking the severity of lower) No visible damage and deterioration in appearance		
Bump IEC 68-2-29	Bump times: 4000 Acceleration: 390m/s <sup>2</sup> Pulse duration: 6ms No visible damage and deterioration in appearance		
Climatic Sequence	Dry heat IEC 68-2-2	Temperature: +110°C Time duration: 16hours	Final measurement No breakdown or flashover; No visible damage and deterioration in appearance and the marking shall be legible Capacitance change: $\Delta C/C : \leq \pm 5\%$ DF change: $C_R \leq 1.0\mu\text{F}$ $\Delta \tan \delta : \leq 0.8\%$ $C_R > 1.0\mu\text{F} \Delta \tan \delta : \leq 0.5\%$ at 1 KHZ . Insulation Resistance $\geq 50\%$ of the value before test
	Damp heat cycle	Test Db, Severity b, the first cycle	
	Cold IEC 68-2-1	Temperature: -40°C Time duration: 2hrs	
	Low Air pressure IEC 68-2-13	Temperature: 15°C—35°C Air Pressure: 8.5KPa Time duration: 1hr (apply $U_R$ at the last 1 minute.	
	Damp heat cycle IEC 68-2-30	Test Db, Severity b, the other cycles, apply $U_R$ for 1minute after the test finished.	

No	APS-1607-011	Version	A/1
Date	2016.7.16	Page	Page 8 of 13
<b>Metallized Polypropylene Film Interference Suppression Capacitor (Class X1)</b>			

<p><b>Damp Heat Test</b> IEC 68-2-3</p>	<p>Temperature: 60°C±2°C  Humidity: 93 +2/-3 %  Time Duration: 56days  No visible damage and deterioration in appearance and the marking shall be legible  Capacitance change: <math>\Delta C/C : \leq \pm 5\%</math>  DF Change: <math>C_R \leq 1.0\mu F \Delta \tan \delta : \leq 0.8\%</math> at 1 KHZ  <math>C_R &gt; 1.0\mu F \Delta \tan \delta : \leq 0.5\%</math> at 1 KHZ  Insulation Resistance: <math>\geq 50\%</math> of the value before test</p>
<p><b>Impulse Voltage</b></p>	<p>Voltage Setting: <math>C_R \leq 1.0\mu F \quad 2.5KV &lt; UP \leq 4.0KV</math>  <math>C_R &gt; 1.0\mu F \quad UP = DC 4.0 / \sqrt{C_R} \text{ KV}</math>  Each capacitor applies same polar pulse for 24 times. The time interval between pulses should be less than 10s. The peak of pulse voltage is showed as above. If monitor reflects three continuous pulse waves which refer to self-healing breakup does not occur, we can stop applying pulse. The capacitor proves well. If there is no self-healing breakup for three times or more after capacitor is applied pulse for 24 times, the capacitor also proves well. But if the rated pulse wave occurs less than 3 times, the capacitor proves invalid. If wave occurs damped vibration, the peak value Upp should be less than 10% of peak pulse voltage. The capacitor should be no permanent breakup and flashover.</p>
<p><b>Durability</b></p>	<p>Temperature: +110°C  Voltage: 1.25UR(50Hz)  Duration: 1000hrs, the voltage will be arise to 1000V (effective value) at intervals of 1 hour,  duration 0.1s. The voltage should be applied to each capacitor though <math>47\Omega \pm 5\%</math> resistance.  No visible damage and deterioration in appearance and the marking shall be legible  Capacitance change: <math>\Delta C/C : \leq \pm 10\%</math>  DF change: <math>C_R \leq 1.0\mu F \Delta \tan \delta : \leq 0.8\%</math> at 1 KHZ  <math>C_R &gt; 1.0\mu F \Delta \tan \delta : \leq 0.5\%</math> at 1 KHZ  Insulation Resistance: <math>\geq 50\%</math> of the value before test</p>
<p><b>Charging &amp; Discharging</b></p>	<p>Charging Times: 10000times  Charging Voltage: <math>\sqrt{2}UR \text{ Vd.c.}</math>  Charging time: 0.5s  Discharging time: 0.5s  Charging resistance: <math>220/C_R \Omega</math> or limit charging current on 1A <math>C_R</math>: rated capacitance (<math>\mu F</math>)  <math display="block">R = \frac{\sqrt{2}U_R}{C_R \times \frac{dU}{dt}} (\Omega)</math> Discharging resistance: <math>dU/dt(V/us) : 100V/\mu s</math>  Capacitance change: <math>\Delta C/C : \leq \pm 10\%</math>  DF change: <math>C_R \leq 1\mu F : \leq 0.8\%</math> (10kHz) <math>C_R &gt; 1\mu F : \leq 0.5\%</math> (1kHz)</p>



No	APS-1607-011	Version	A/1
Date	2016.7.16	Page	Page 9 of 13
<b>Metallized Polypropylene Film Interference Suppression Capacitor (Class X1)</b>			

	Insulation Resistance: $\geq 50\%$ of the value before test
--	---

Flame Resistance Test	<p>Flame Resistance Class: B          Flame Applying Times: 1 time          Flame Applying Time: <math>250 &lt; V(\text{mm}^3) \leq 500</math> 20s  <math>500 &lt; V(\text{mm}^3) \leq 1750</math> 30s  <math>V(\text{mm}^3) &gt; 1750</math> 60s</p> <p>Burning time for rest flame: 30s          Burn dropping or dropped hot part can not fire face tissues. No requirement of charge measurement.</p>
Pyrophorosity Test	<p><math>U = U_R</math>  <math>U_i = 4.0 \text{ kV}^{+7} \%</math></p> <p>Each sample should bear one storage capacitor for 20 times. Discharging storage charge for tested capacitor to <math>U_i</math> voltage. The interval between discharging should be 5S.</p> <p>During the test, U is applied on two terminal of capacitor and keep for 2 min at the last discharge unless melting fuse make the circuit open.</p> <p>Gauze which wind on capacitor should be not burned by flame. No requirement of current measurement.</p>

### ◇ Security certification

Mark	Specification	File No.
	IEC 60384-14:2013 GB/T6346	CQC19001233550
	IEC 60384-14:2013	40052395
	UL 60384-14:2009 CSA E60384-14:09	E334332
	IEC 60384-14(ed.4)	CN49326

No	APS-1607-011	Version	A/1
Date	2016.7.16	Page	Page 10 of 13
<b>Metallized Polypropylene Film Interference Suppression Capacitor (Class X1)</b>			

## ◇ Soldering Temperature VS Time

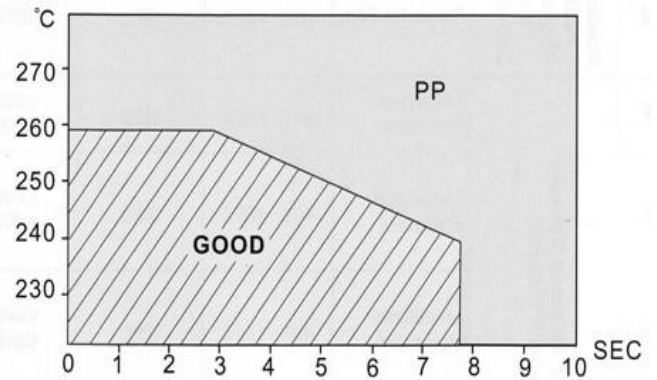
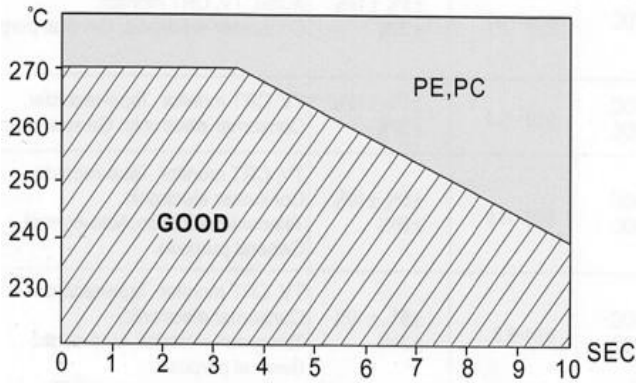

## ◇ Temperature Characteristics

◇

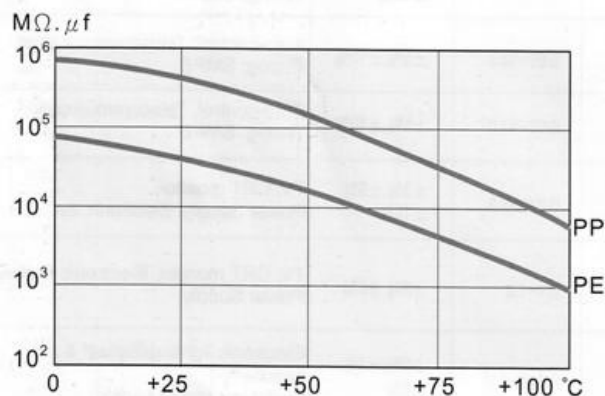
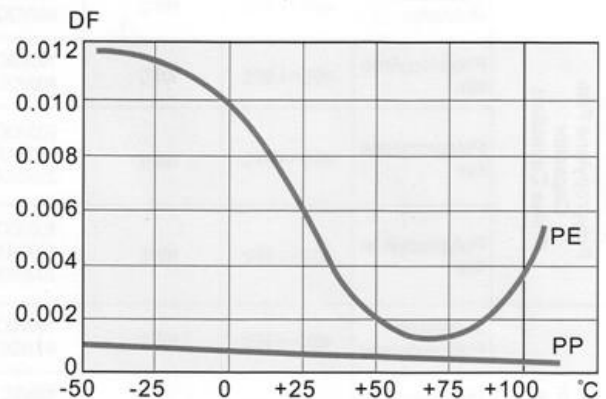
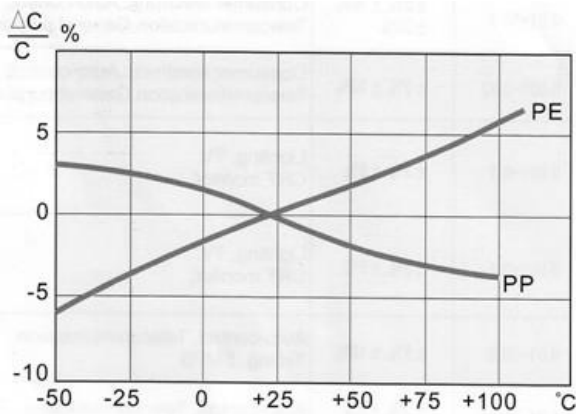

PP: 聚丙烯薄膜 (Polypropylene Film)

PE: 聚酯薄膜 (Polyester Film)

No	APS-1607-011	Version	A/1
Date	2016.7.16	Page	Page 11 of 13
<b>Metallized Polypropylene Film Interference Suppression Capacitor (Class X1)</b>			

## ✧ Frequency Characteristics

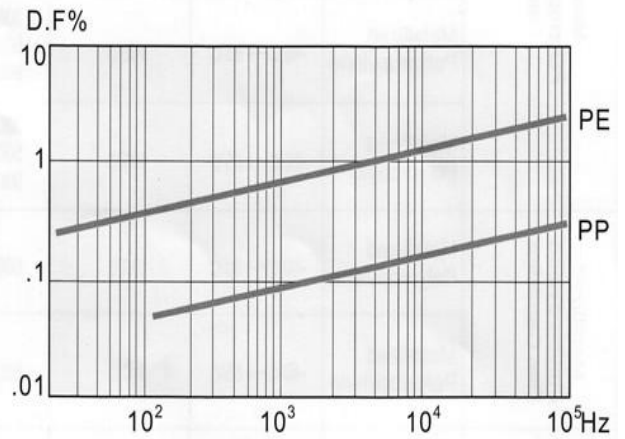
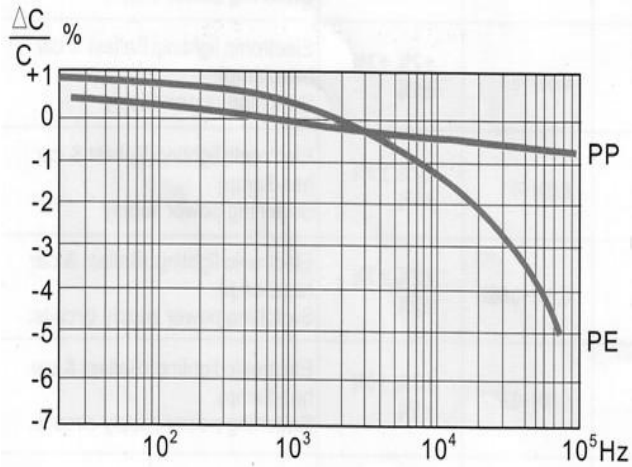

## ✧ Impedance and frequency curve

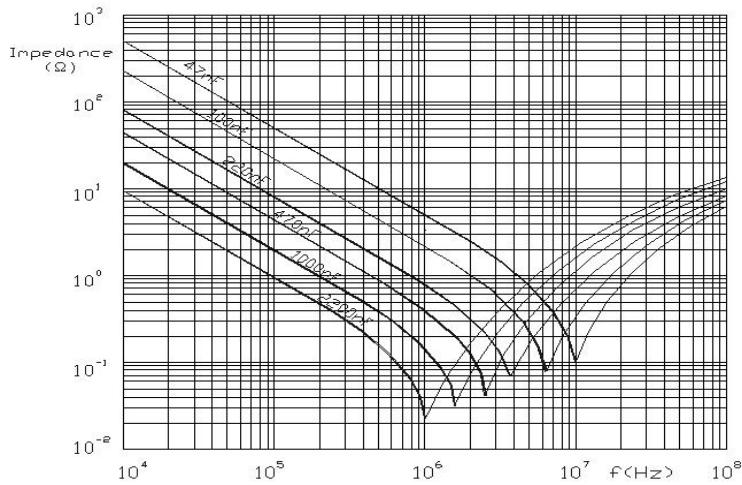

## ✧ Resonance Frequency and Capacitance Curve

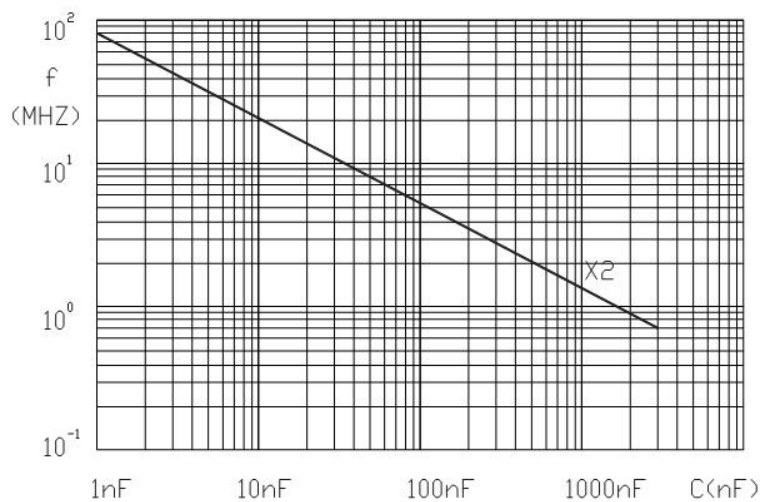

No	APS-1607-011	Version	A/1
Date	2016.7.16	Page	Page 12 of 13
<b>Metallized Polypropylene Film Interference Suppression Capacitor (Class X1)</b>			

## ◇Marking Specification

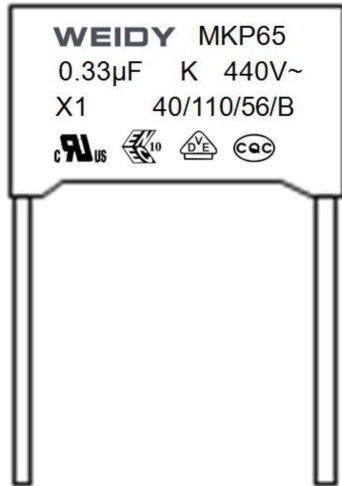

Content	Description	Content	Description
<b>WEIDY</b>	Logo	40/110/56	Climate Catagory
MKP65	Type		ENEN-VDE Approval
0.33 µ F	Capacitance		CQC approval
K	Capacitance Tolerance	B	Flame Resistance Class
440V~	Rated Voltage		UL, CUL Approval
X1	Series		

## ◇Taping Drawing&Dimensions

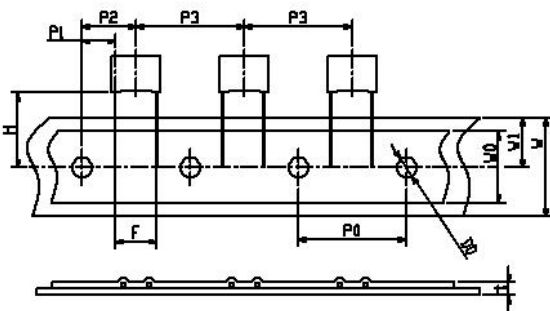

Fig.1

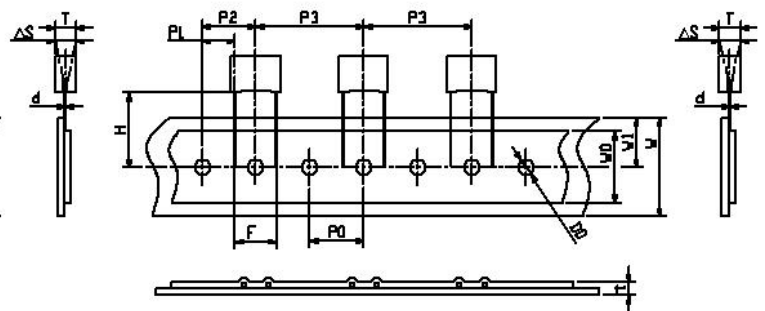
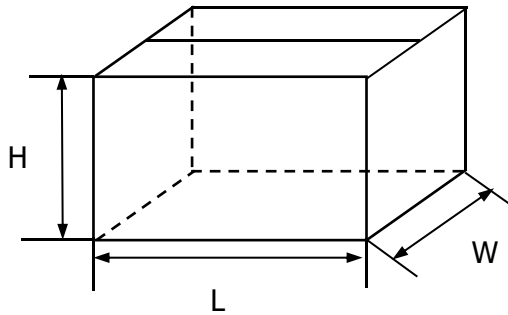

Fig.2

Technique Data	Code	Size (mm)					Technique Data	Code	Size (mm)				
		P=5	P=7.5	P=10	P=15	Tolerance			P=5	P=7.5	P=10	P=15	Tolerance
Taping Type		Fig1	Fig1	Fig2	Fig2		Taping Type		Fig1	Fig1	Fig2	Fig2	
Section distance	P3	12.7	12.7	25.4	25.4	±1.0	Tape width	W	18.0	18.0	18.0	18.0	±0.5
Distance between two hole	P0	12.7	12.7	12.7	12.7	±0.3	Jack position	W1	9.0	9.0	9.0	9.0	±0.5
Leads position	P1	3.85	2.6	7.7	5.2	±0.7	Bending height	H0	16	16	16	16	±0.5
Pitch for forming type	F	5.0	7.5	10.0	15.0	±0.5	Taping Height	H	18.5	18.5	18.5	18.5	±0.5
Body position	P2	6.35	6.35	12.7	12.7	±1.3	Dia of hole	Do	4.0	4.0	4.0	4.0	±0.3
Product Inclination	ΔS	0	0	0	0	±0.2	Taping thickness	t	0.7	0.7	0.7	0.7	±0.2

## Metallized Polypropylene Film Interference Suppression Capacitor (Class X1)

### ◇Carton Size



#### Out packing box for bulk

L: 480mm

W: 320mm

H: 280mm

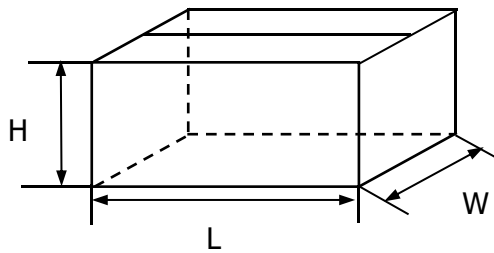

#### Inner packing box for bulk

L: 280mm

W: 225mm

H: 120mm

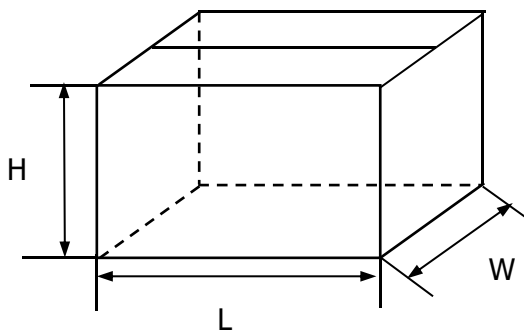

#### Out packaging box for taping

L: 640mm

W: 360mm

H: 290mm

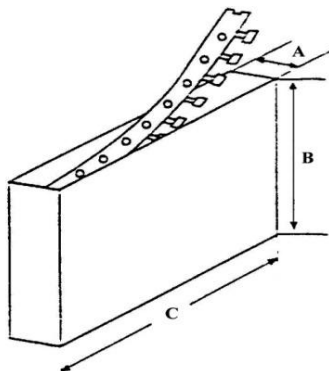

#### Inner packing box for ammo-pack

A: 50mm

B: 320mm

C: 330mm