

未注公差/General tolerances (mm)													
0 ~ 3	>3 ~ 6	>6 ~ 10	>10 ~ 18	>18 ~ 30	>30 ~ 50	>50 ~ 80	>80 ~ 120	>120 ~ 180	>180 ~ 250	>250 ~ 315	>315 ~ 400	>400 ~ 500	>500
±0.12	±0.18	±0.22	±0.26	±0.31	±0.37	±0.57	±0.80	±0.93	±1.05	±1.15	±1.60	±2.20	±2.50

0.1/10
±2°

Transfer or duplication of this document as well as the utilization of its contents without the written permission of DEGSON is prohibited. All rights reserved for patent.

DEGSON		MATERIAL: 材质	SURFACE/COLOR: 表面处理	
APPD:		MAT NO./REV: 物料编码 / 版本	MAT STATUS: 物料状态	
CHKD:		NAME: EMS-350A-120-S-OR-XX		
DRFT: Chen Q	2024.1.18	DRAWING NO.	TYPE	DRAWING STATUS
REV	ECN	图号	图纸类型	图纸状态
00	ECN			SCALE: 1.2:1
				SHEET: 1/2

00	ECN	/	Chen Q	2024.1.18
REV	ECN	DESCRIPTION	DRFT	DATE

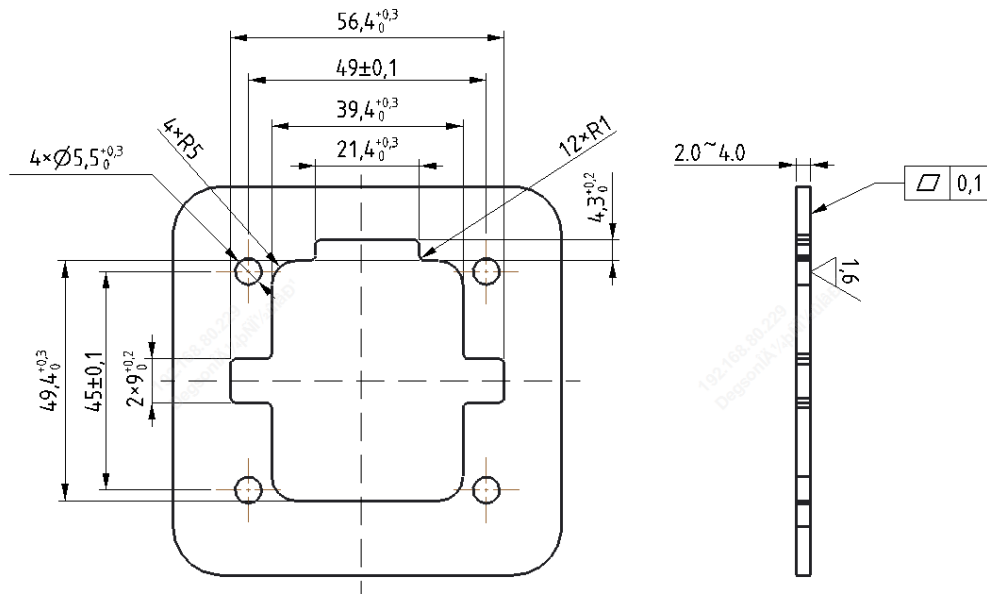

Recommended panel

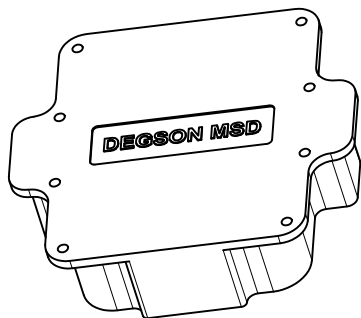

Socket dust cover :needs to be ordered separately

未注公差/General tolerances(mm)											0.1/10		
0 ~ 3	>3 ~ 6	>6 ~ 10	>10 ~ 18	>18 ~ 30	>30 ~ 50	>50 ~ 80	>80 ~ 120	>120 ~ 180	>180 ~ 250	>250 ~ 315		>315 ~ 400	>400 ~ 500
±0.12	±0.18	±0.22	±0.26	±0.31	±0.37	±0.57	±0.80	±0.93	±1.05	±1.15	±1.60	±2.20	±2.50

技术要求/Technical requirements:	
额定电压电流/Rated Voltage/Current	1500V/350A
接触阻抗/Contact resistance	≤0.25mΩ
绝缘电阻/Insulation resistance	5000 MΩ MIN (Drying) 200MΩ MIN (RH 95%)
耐电压/Withstanding voltage	POWER CONTACT: 4000V AC; HVIL CONTACT 600V AC
防水等级/Levels of protection	IP67 (Matching state)
盐雾要求/Salt Spray	240h (Matching state)
机械寿命/Mechanical cycle	200 Cycling
阻燃等级/Flame retardant rating	UL94-V0
使用温度范围/Operating temperature(° C)	-40~+125
符合RoHS环保要求/Conform to RoHS	Yes
认证信息/Certification	UL, TUV

EMS-350A-120-S-OR-XX

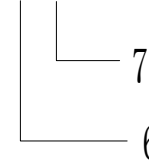

- 6. Color
OR--orange
- 7. Serial number reference
XX=HV or 00 , 01 , 02 , 0399
HV--with interlock separately packaged
00--without interlock
"01 , 02 , 0399--No constructional differences.
Models differ only in model name and marking label"

	MATERIAL: 材质	SURFACE/COLOR: 表面处理	
	MAT NO./REV: 物料编码 / 版本	MAT STATUS: 物料状态	
APPD:	NAME		
CHKD:	EMS-350A-120-S-OR-XX		
DRFT: Chen Q	DRAWING NO.	TYPE	DRAWING STATUS
2024.1.18	图号	图纸类型	图纸状态
SCALE	SHEET		
1:1	2/2		

00	ECN	/	Chen Q	2024.1.18
REV	ECN	DESCRIPTION	DRFT	DATE

Transfer or duplication of this document as well as the utilization of its contents without the written consent of DEGSON is prohibited. 未经授权复制或传播本文件以及使用其内容，未经 DEGSON 书面许可，是严格禁止的。 版权所有，保留所有权利。 如有变更，恕不另行通知。