

To. :

DATE : 20 . . .

RoHS 1,2 and 3	Halogen Free
----------------	--------------

SPECIFICATION

PRODUCT : Chipcell Carbon[®]

MODEL : DCSR3R6474T

WRITTEN	CHECKED	APPROVED

KORCHIP CORP.

KORCHIP B/D, 359, Manan-ro, Manan-gu, Anyang-si, Gyeonggi-do, KOREA

TEL : 82 - 31 - 361 - 8000

FAX : 82 - 31 - 361 - 8080

Index

Page No.	ITEM	etc.
1	Cover Page	
2	Index	
3	Revision History	
	Manufacturer Information	
4	1. Scope	
	2. Part Number System	
	3. General Specifications	
5	4. Appearance and Dimensions	
6	5. Reliability Specifications	
7-8	6. Packing Specifications	
9	7. Labeling Standards	
10	8. Measuring Method of Characteristics	
11	9. Mounting	
12-13	10. Cautions for Use	
14	11. Environmental Management	

Revision History

No.	Documentation	Check	Description of Revision	Approval	Date
0	Y.S. Heo (R&D)	K.B. Chung (Q.A.)	Preliminary Version Release	B.I. Lim (R&D)	Apr. 25, 2024

Manufacturer Information

Manufacturer : Korchip Corporation

Location : KORCHIP B/D, 359, Manan-ro, Manan-gu, Anyang-si, Gyeonggi-do,
KOREA

Tel. : +82-31-361-8000

Fax. : +82-31-361-8080

1. Scope

This specification applies to Chipcell Carbon(Electric Double Layer Capacitor ; EDLC), submitted to specified customer in cover page.

2. Part Number System

<u>DCSR</u>	<u>3R6</u>	<u>474</u>	<u>T</u>
①	②	③	④

① Series Name : DC(Double layer capacitor - Coin type), S(Small size), R(Reflow type)

② Rated Voltage : 3.6VDC

③ Capacitance : 0.47 F (474 = $47 \times 10^{+4}$ uF)

④ Special Suffix : high Temperature identification code (+85°C)

3. General Specifications

ITEMS	SPECIFICATIONS
Rated Voltage	3.6 VDC
Operating Temp.	-40 ~ +85 °C
Capacitance	0.47 F
Capacitance Tolerance	-20 ~ 80 %
Equivalent Series Resistance (ESR)	Less than 50Ω

4. Appearance and Dimensions

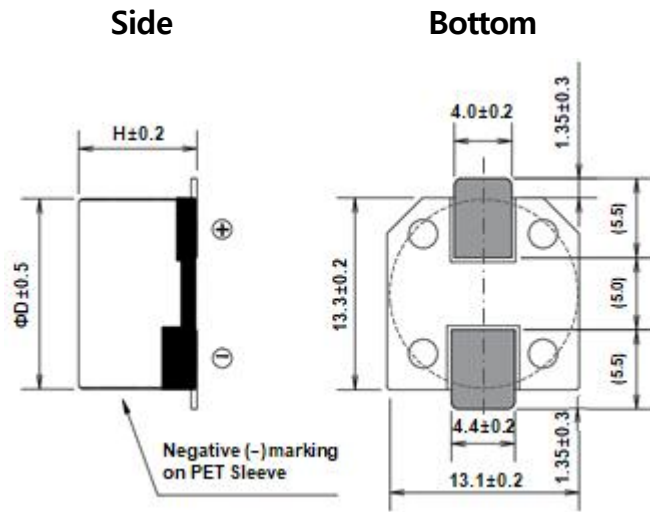

Dimensions (mm)	
ϕD	H
13.2	8.2

Recommendable PCB Layout (Unit: mm)

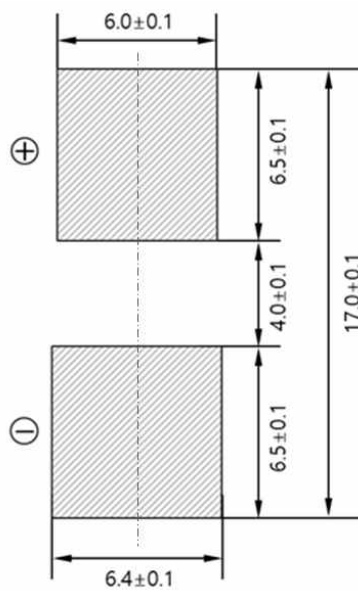

5. Reliability Specifications

Item		Specification		Test Condition													
Temperature Characteristics	Capacitance Change	Step 2	Within $\pm 50\%$ of Initial Value	Measure electrical characteristics after exposing Chipcell Carbon to each temperature atmosphere for one(1) hour <table border="1"> <thead> <tr> <th>Step</th> <th>Temperature</th> </tr> </thead> <tbody> <tr> <td>1</td> <td>20\pm2$^{\circ}$C</td> </tr> <tr> <td>2</td> <td>-40\pm2$^{\circ}$C</td> </tr> <tr> <td>3</td> <td>20\pm2$^{\circ}$C</td> </tr> <tr> <td>4</td> <td>85\pm2$^{\circ}$C</td> </tr> <tr> <td>5</td> <td>20\pm2$^{\circ}$C</td> </tr> </tbody> </table>		Step	Temperature	1	20 \pm 2 $^{\circ}$ C	2	-40 \pm 2 $^{\circ}$ C	3	20 \pm 2 $^{\circ}$ C	4	85 \pm 2 $^{\circ}$ C	5	20 \pm 2 $^{\circ}$ C
	Step		Temperature														
	1	20 \pm 2 $^{\circ}$ C															
	2	-40 \pm 2 $^{\circ}$ C															
	3	20 \pm 2 $^{\circ}$ C															
	4	85 \pm 2 $^{\circ}$ C															
5	20 \pm 2 $^{\circ}$ C																
ESR	8Times or less than Initial Value																
Capacitance Change	Step 4	Within $\pm 30\%$ of Initial Value															
ESR		4Times or less than Initial Value															
Capacitance Change	Step 5	Within $\pm 10\%$ of Initial Value															
ESR Change		Within $\pm 10\%$ of Initial Value															
Reflow Soldering Effect	Capacitance	Spec. Value		Pb-Free Reflow Solder Peak Temp. : 260 \pm 5 $^{\circ}$ C Duration at Peak Temp. : 5 \pm 0.5sec.													
	Appearance	No Marked Defect															
Humidity Resistance	Capacitance Change	$\pm 30\%$ of Initial Value		Temp. : 40 \pm 2 $^{\circ}$ C Humidity : 90 ~ 95%RH Time : 240 \pm 8 Hours No Voltage Applied													
	ESR	3Times or less than Spec. Value															
	Appearance	No Marked Defect															
Self Discharge Characteristics	Voltage	More than 2.5Vdc	Charging Condition	Voltage : 3.6Vdc Current : 50mA Charge Time : 24 Hours													
			Self Discharge Condition	Duration : 24 Hours Temp. : Less than 25 $^{\circ}$ C Humidity : Less than 70%RH													
Terminal Strength	Appearance	Terminals shall not be separated	Load 1kg , 10 \pm 1 Sec.														
Terminal Bend Strength			Load 1kg , Angle 90 $^{\circ}$, 1Cycle														
Endurance	Capacitance Change	Within $\pm 30\%$ of Initial Value		Temp. : 85 \pm 2 $^{\circ}$ C Test Time : 1,000Hours Applied Voltage : 3.6Vdc													
	ESR	4Times or less than Spec. Value															
	Appearance	No Marked Defect															
Shelf Life	Capacitance Change	Within $\pm 30\%$ of Initial Value		Temp. : 85 \pm 2 $^{\circ}$ C Test Time : 1,000 Hours No Voltage Applied													
	ESR	4Times or less than Spec. Value															
	Appearance	No Marked Defect															

6. Packing Specifications

1) Carrier Tape

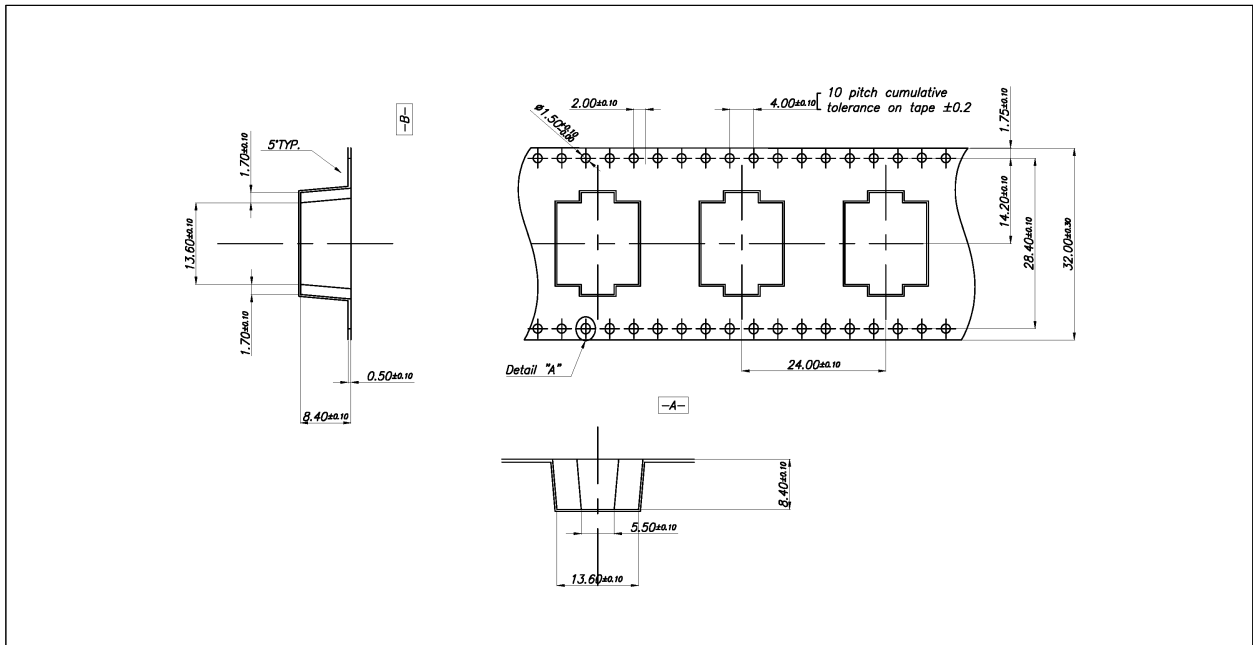

2) Reel

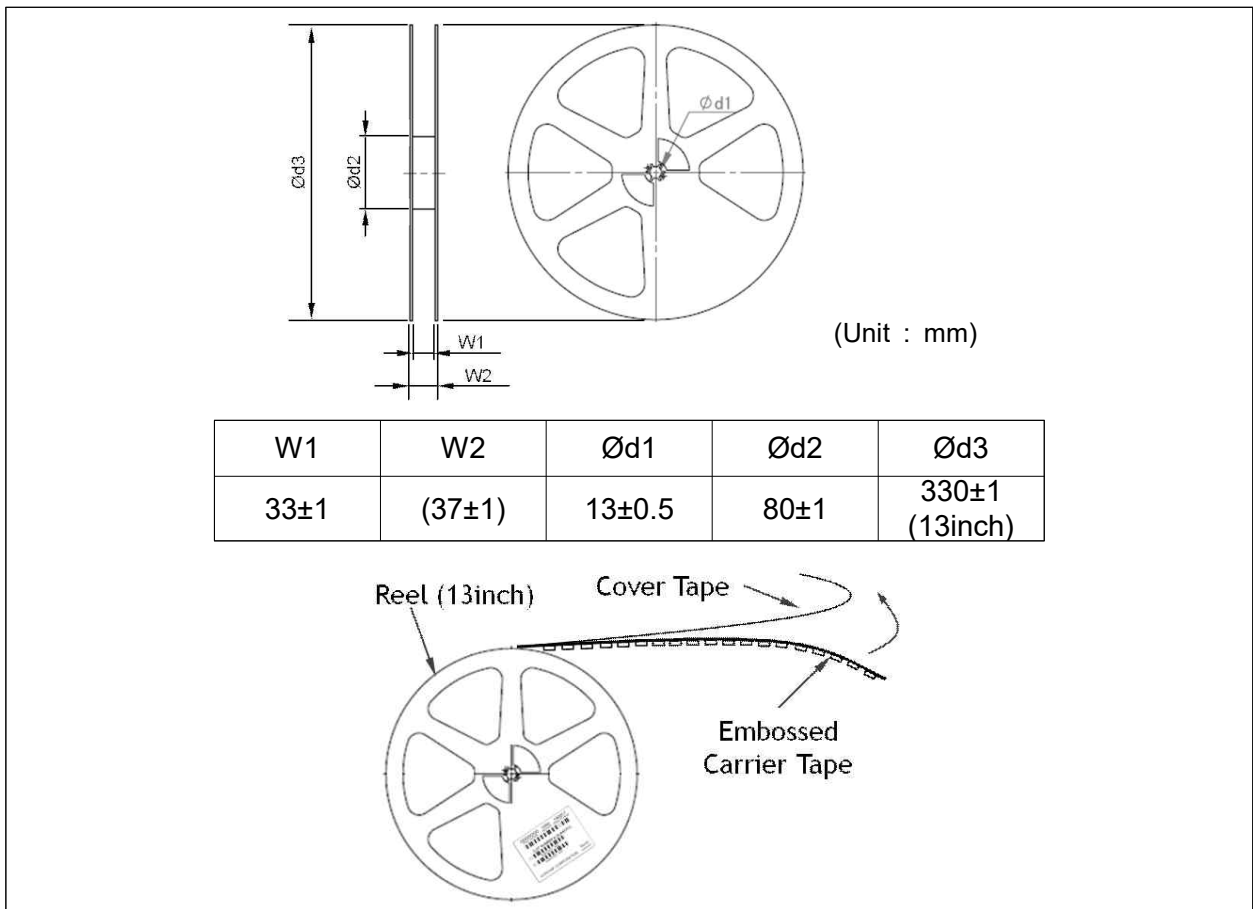

3) Box

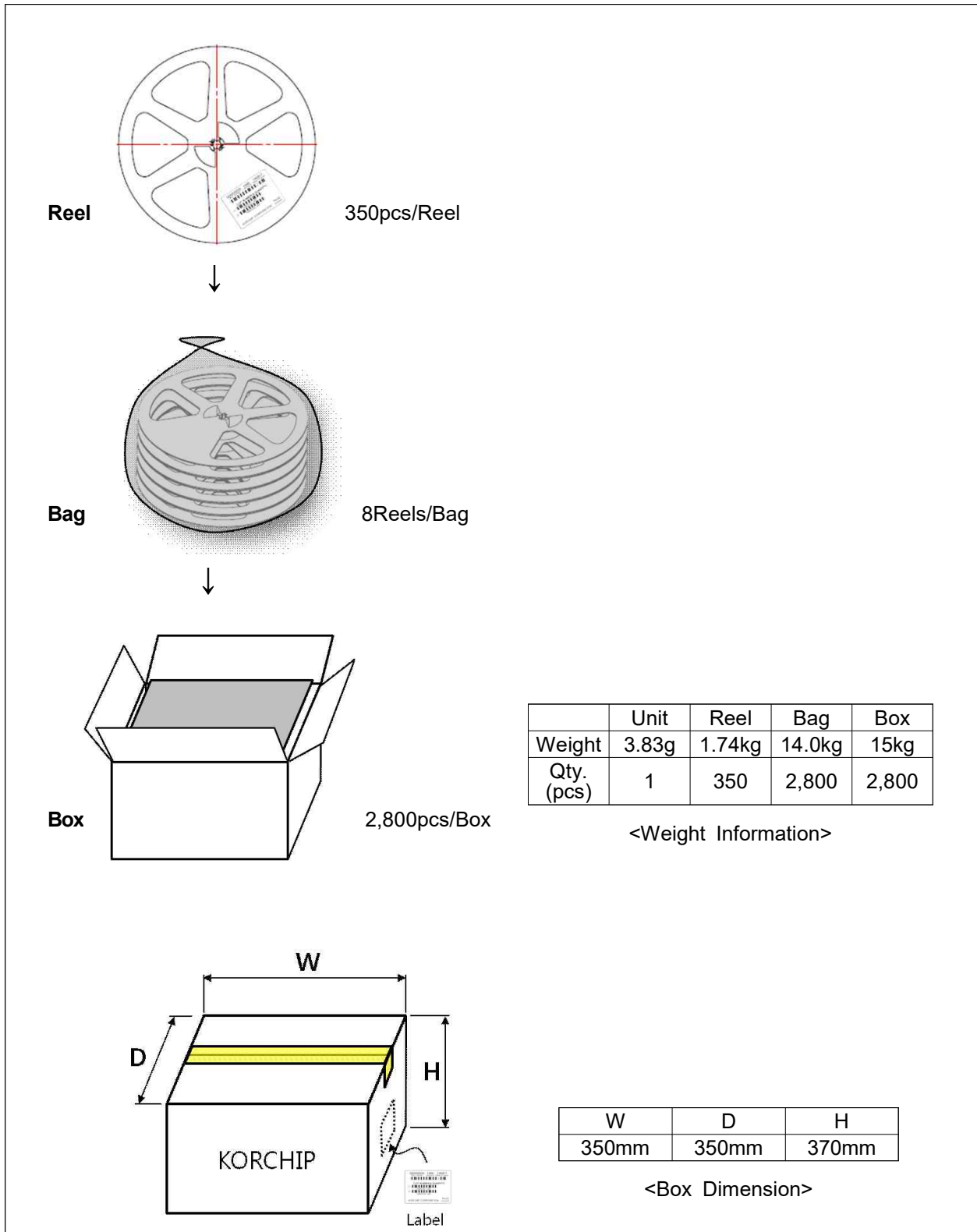

7. Labeling Standards

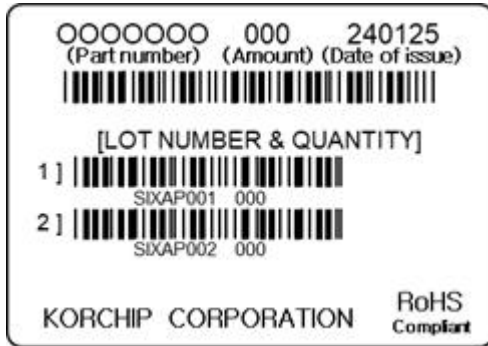

← (Example)

Lot No. System

Ex.) S I X A C 002

① ② ③ ④ ⑤ ⑥

- ① Product Code : S (Chipcell Carbon)
- ② Production Year Code : A (2016), B (2017), C (2018), ... , H (2023), I (2024)...
- ③ Factory Identification Code : X (Factory X)
- ④ Production Month Code : A (Jan.), B (Feb.), ... , J (Oct.), K (Nov.), L (Dec.)
- ⑤ Production Date Code : 1 (1st), 2 (2nd), ... , 9 (9th), A (10th), B (11th), C (12th) ...
Q (26th), R (27th), S (28th), ... , V (31th)
- ⑥ Lot Issuing Serial Code : 001 (First lot of a specific day), 002 (Second lot of a specific day), 003 (Third lot of a specific day)...

8. Measuring Method Of Characteristics

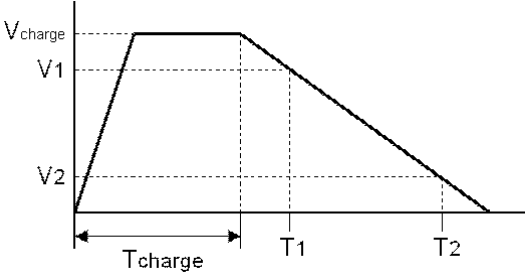
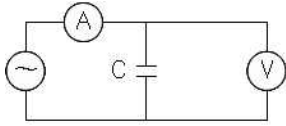
Capacitance	<p>1) Charge the Chipcell Carbon with constant current $I_{\text{charge}}(=0.05\text{A})$ to $V_{\text{charge}}(=3.6\text{V})$ then keep charging for $T_{\text{charge}}(=1800\text{sec.})$</p> <p>2) Discharge the Chipcell Carbon with constant current $I_{\text{disch}}(=0.002\text{A})$ while measure the discharge time T_1, T_2 between $V_1(=2.8\text{V})$ and $V_2(=1.4\text{V})$.</p> <p>3) Calculate capacitance using the following formula.</p> <div style="text-align: center;">  $C = \frac{I_{\text{disch}} \times (T_1 - T_2)}{V_1 - V_2}$ </div>
Equivalent Series Resistance (ESR @1kHz)	<ul style="list-style-type: none"> ● Measure ESR by the LCR meter. (Frequency:1kHz, Bias Voltage : $0^{+0.05}\text{V}$) or ● Calculate ESR using the following formula. <div style="display: flex; align-items: center;"> <div style="flex: 1;">  $\text{ESR}[\Omega] = V / i$ </div> <div style="flex: 2;"> $R[\Omega] = V[V] / I[A] \quad * i[\text{mA}] = I[A] \times 10^{-3}$ <p>R : Internal resistance(ESR) [Ω] V : Measured voltage between terminals [V] i : Current 1mA(A.C.)</p> </div> </div>
<p>☞ The Chipcell Carbon should be shorted before each measurement as follows ; Capacitance : 60 min. , ESR : 15 min. , LC : 15 min.</p>	

9. Mounting

Excessive heat stress may result in the deterioration of the electrical characteristics of the Chipcell Carbon and electrolyte leakage due to the rise in internal pressure.

Use the general reference chart then set soldering temperature and time.

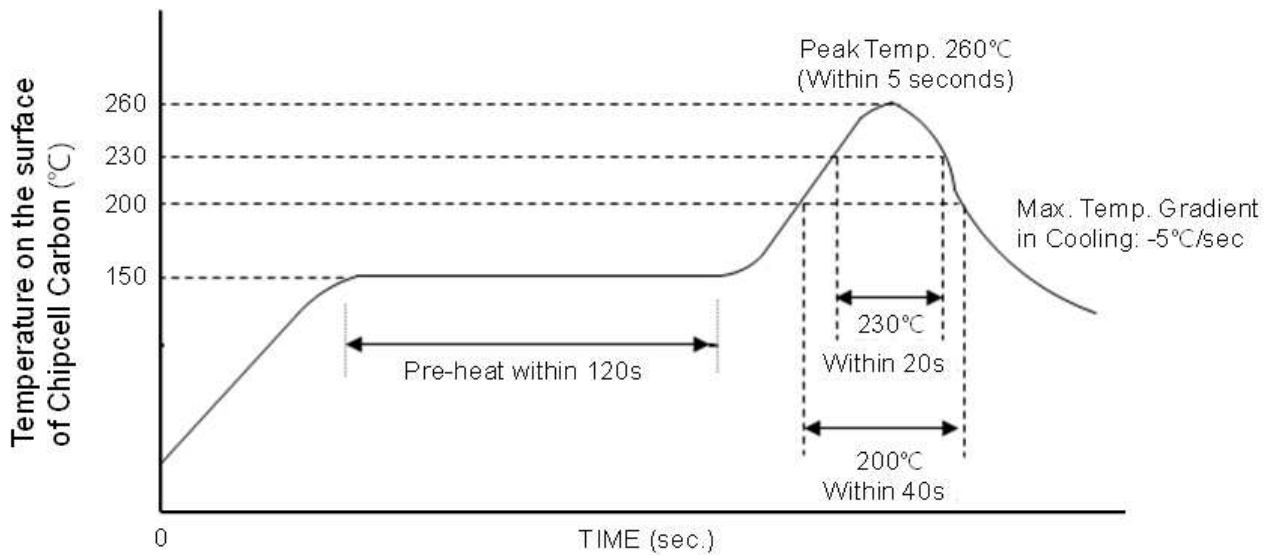

The time of repeated reflow soldering must be two times or less.

- ※ Do not use reflow soldering when the cell voltage is above 0.3V.
- ※ After SMT soldering, the sleeve may over-shrink or be deformed partially, however it makes no electrical or functional problem to the capacitor.

10. Cautions for Use

Please be careful for following points when you use Chipcell Carbon.

1) Do not apply more than rated voltage.

If you apply more than rated voltage, Chipcell Carbon's electrolyte will be decomposed and its ESR increase. At the worst, it may be broken.

2) Do not use Chipcell Carbon for ripple absorption.

3) Polarity

Please mount it in accordance with its polarity.

4) Operating environment and lifetime

Chipcell Carbon shows faster deterioration in high temperature operation. The lifetime of Chipcell Carbon follows the general lifetime acceleration rule of double or half per every 10°C of ambient temperature decrease or increase respectively. A large temperature difference in one day or humid operating environment results in dew condensation on the surface of Chipcell Carbon and it may cause fast deterioration or electrolyte leakage of Chipcell Carbon.

If Chipcell Carbon is used in an electronic or electrical device over a long period of time especially in high temperature or high humidity environment, please check it periodically and replace it when necessary.

5) Cleaning

Some detergent or high temperature drying causes deterioration of Chipcell Carbon. If you wash Chipcell Carbon, Consult us.

6) Following figure shows the general back-up circuit.

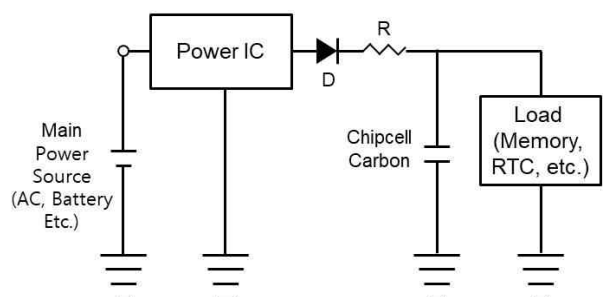

D : Diode to prevent the reverse current
R : Resistor to control the charging current

7) Short-circuit of Chipcell Carbon

DO NOT short-circuit between terminals of Chipcell Carbon without resistor.

8) Storage

In long term storage, please store Chipcell Carbon in following condition;

- ① TEMP. : 15 ~ 35 °C
- ② HUMIDITY : Less than 75%RH
- ③ Non-dust, non-acidic and/or non-alkaline atmosphere
- ④ Avoid direct sun light, strong magnetic field

Storage period limit is one(1) year when a Chipcell Carbon is stored in the above condition. Storage in improper condition may cause some damage to the Chipcell Carbon.

If the storage period exceed one(1) year in the customer's warehouse, please contact the manufacturer.

9) Do not disassemble Chipcell Carbon . It contains electrolyte.

10) Series connection of Chipcell Carbon

Over-rated voltage may be applied to a single Chipcell Carbon in series connection due to the deviation of capacitance and ESR of each Chipcell Carbon. Please inform us if you are using Chipcell Carbons in series connection and please design so as not to apply over-rated voltage to each Chipcell Carbon, and use Chipcell Carbons from same lot.

11) The tips of Chipcell Carbon terminals are very sharp. Please handle with care.

12) Industrial Application

Some industrial applications require a very high level of reliability to its parts including carbon-base 2nd. batteries i.e. Chipcell Carbons. Therefore if the Chipcell Carbon is to be used in an industrial application such as factory machinery, heavy electricity, etc. periodic inspection of Chipcell Carbon is necessary. If there found any problem with the Chipcell Carbon, please replace it.

13) Use of Functional Coating Chemicals

Some solvents of functional coating chemicals which applied on the same PCB with the Chipcell Carbon may cause undesired effects on it such as surface oxidation or electrolyte leakage. When apply those chemicals, be careful of not coating the Chipcell Carbon's surface.

11. Environmental Management

All Chipcell Carbon products are RoHS 1, 2 and 3 compliant, Halogen Free and environment friendly.

Series	RoHS 1,2 directive (Pb, Cr+6, Hg, Cd, PBB, PBDE)	ELV directive (Pb, Cr+6, Hg, Cd)	PVC	Halogen Flame Retardant Free (Cl, Br)	RoHS 3 directive (DEHP, BBP, DBP, DIBP)	etc.
DCSR	N.D.	N.D.	N.D.	N.D.	N.D.	

* N.D. : Not Detected or Within Permitted Range