



WINSTAR Display Co.,Ltd.
華凌光電股份有限公司



Winstar Display Co., LTD

華凌光電股份有限公司



WEB: <https://www.winstar.com.tw> E-mail: sales@winstar.com.tw

SPECIFICATION

CUSTOMER : _____

MODULE NO.: WF57VTIBCDANO#

APPROVED BY: (FOR CUSTOMER USE ONLY)	PCB VERSION:	DATA:
--	---------------------	--------------

SALES BY	APPROVED BY	CHECKED BY	PREPARED BY
			葉虹蘭
ISSUED DATE: 2023/03/31			

TFT Display Inspection Specification: <https://www.winstar.com.tw/technology/download.html>

Precaution in use of TFT module: <https://www.winstar.com.tw/technology/download/declaration.html>



RECORDS OF REVISION

DOC. FIRST ISSUE

VERSION	DATE	REVISED PAGE NO.	SUMMARY
0	2023/03/31		First issue

WINSTAR DISPLAY Co., Ltd.

Contents

- 1.Module Classification Information
- 2.Summary
- 3.General Specifications
- 4.Absolute Maximum Ratings
- 5.Electrical Characteristics
- 6.DC Characteristics
- 7.Interface timing
- 8.Optical Characteristics
- 9.Interface
- 10.Block Diagram
- 11.Reliability
- 12.Contour Drawing
- 13.Initial Code For Reference

1.Module Classification Information

W F 57 V T I B C D A N 0 #
 ① ② ③ ④ ⑤ ⑥ ⑦ ⑧ ⑨ ⑩ ⑪ ⑫ ⑬

①	Brand : WINSTAR DISPLAY CORPORATION											
②	Display Type : F→TFT Type, J→Custom TFT											
③	Display Size : 5.7" TFT											
④	Model serials no.											
⑤	Backlight Type :	F→CCFL, White S→LED, High Light White					T→LED, White Z→Nichia LED, White					
⑥	LCD Polarize Type/ Temperature range/ Gray Scale Inversion Direction	A→Transmissive, N.T, IPS TFT C→Transmissive, N. T, 6:00 ; F→Transmissive, N.T,12:00 ; I→Transmissive, W. T, 6:00 K→Transflective, W.T,12:00 L→Transmissive, W.T,12:00 N→Transmissive, Super W.T, 6:00					Q→Transmissive, Super W.T, 12:00 R→Transmissive, Super W.T, O-TFT V→Transmissive, Super W.T, VA TFT W→Transmissive, Super W.T, IPS TFT X→Transmissive, W.T, VA TFT Y→Transmissive, W.T, IPS TFT Z→Transmissive, W.T, O-TFT					
⑦	A : TFT LCD B : TFT+SCREW HOLES+CONTROL BOARD C : TFT+ SCREW HOLES +A/D BOARD D : TFT+ SCREW HOLES +A/D BOARD+CONTROL BOARD E : TFT+ SCREW HOLES +POWER BOARD					F : TFT+CONTROL BOARD G : TFT+ SCREW HOLES H : TFT+D/V BOARD I : TFT+ SCREW HOLES +D/V BOARD J : TFT+POWER BD						
⑧	Resolution:											
	A	128160	B	320234	C	320240	D	480234	E	480272	F	640480
	G	800480	H	1024600	I	320480	J	240320	K	800600	L	240400
	M	1024768	N	128128	P	1280800	Q	480800	R	640320	S	480128
	T	800320	U	8001280	V	176220	W	1280398	X	1024250	Y	1920720
	Z	800200	2	1024324	3	7201280	4	19201200	5	1366768	6	1280320
⑨	D: Digital L : LVDS M:MIPI											
⑩	Interface:											
	N	Without control board			A	8Bit		B	16Bit		H	HDMI
	I	I2C Interface			R	RS232		S	SPI Interface		U	USB
⑪	TS:											
	N	Without TS			T	Resistive touch panel			C	Capacitive touch panel (G-F-F)		
	G	Capacitive touch panel (G-G)					C1	Capacitive touch panel (G-F-F)+OCA				
	C2	Capacitive touch panel (G-F-F)+OCR					G1	Capacitive touch panel (G-G)+OCA				
	G2	Capacitive touch panel (G-G)+OCR					B	CTP+GG+USB				
⑫	Version: X:Raspberry pi											
⑬	Special Code	#:Fit in with ROHS directive regulations										

--	--	--

WINSTAR DISPLAY Co., Ltd.

2.Summary

TFT 5.7” is a TN transmissive type color active matrix TFT liquid crystal display that use amorphous silicon TFT as switching devices. This module is a composed of a TFT_LCD module, It is usually designed for industrial application and this module follows RoHs.

WINSTAR DISPLAY Co., Ltd.

3. General Specifications

Item	Dimension	Unit
Size	5.7	inch
Dot Matrix	320 x RGBx240(TFT)	dots
Module dimension	160(W) x 109(H) x12.4 max(D)	mm
Active area	115.2 x 86.40	mm
Dot pitch	0.12 x 0.36	mm
LCD type	TFT, Normally White, Transmissive	
View Direction	12 o'clock	
Gray Scale Inversion Direction	6 o'clock	
Aspect Ratio	4:3	
Backlight Type	LED, Normally White	
Controller IC	SSD1963	
Interface	Digital 8080 family MPU	
With /Without TP	Without TP	
Surface	Glare	

*Color tone slight changed by temperature and driving voltage.

4. Absolute Maximum Ratings

Item	Symbol	Min	Typ	Max	Unit
Operating Temperature	TOP	-20	—	+70	°C
Storage Temperature	TST	-30	—	+80	°C

Note: Device is subject to be damaged permanently if stresses beyond those absolute maximum ratings listed above

1. Temp. $\leq 60^{\circ}\text{C}$, 90% RH MAX. Temp. $> 60^{\circ}\text{C}$, Absolute humidity shall be less than 90% RH at 60°C

WINSTAR DISPLAY Co., Ltd.

5. Electrical Characteristics

5.1. Operating conditions:

Item	Symbol	Condition	Min	Typ	Max	Unit	Remark
Supply Voltage For LCM	VDD	—	3.0	3.3	3.6	V	-
Supply Current For LCM	IDD	—	—	120	180	mA	Note1

Note 1 : This value is test for VDD=3.3V , Ta=25 °C only

5.2. LED driving conditions

Parameter	Symbol	Min.	Typ.	Max.	Unit	Remark
LED current		-	140	-	mA	
Power Consumption		1260	-	1470	mW	
LED voltage	VBL+	9.0	-	10.5	V	Note 1
LED Life Time		-	50,000	-	Hr	Note 2,3,4

Note 1 : There are 1 Groups LED

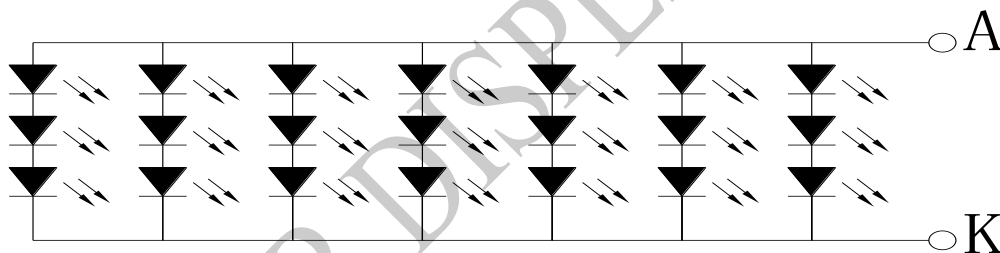

Note 2 : Ta = 25 °C

Note 3 : Brightness to be decreased to 50% of the initial value

Note 4 : The single LED lamp case

6.DC CHARATERISTICS

Parameter	Symbol	Rating			Unit	Condition
		Min	Typ	Max		
Low level input voltage	V_{IL}	0	-	0.3VDD	V	
High level input voltage	V_{IH}	0.7VDD	-	VDD	V	

WINSTAR DISPLAY Co., Ltd.

7. Interface timing

7.1. 8080 Mode

The 8080 mode MCU interface consist of CS#, D/C#, RD#, WR#, Data Bus. This interface use WR# to define a write cycle and RD# for read cycle. If the WR# goes low when the CS# signal is low, the data or command will be latched into the system at the rising edge of WR#. Similarly, the read cycle will start when RD# goes low and end at the rising edge of RD#.

7.2. 8080 Mode Write Cycle

Symbol	Parameter	Min	Typ	Max	Unit
fMCLK	System Clock Frequency	1	-	110	MHz
tMCLK	System Clock Period	1/ fMCLK	-	-	ns
tPWCSH	Control Pulse High Width Write Read	13 30	1.5* tMCLK 3.5* tMCLK	-	ns
tPWCSL	Control Pulse Low Width Write (next write cycle) Write (next read cycle) Read	13 80 80	1.5* tMCLK 9* tMCLK 9* tMCLK	-	ns
tAS	Address Setup Time	1	-	-	ns
tAH	Address Hold Time	2	-	-	ns
tDSW	Write Data Setup Time	4	-	-	ns
tDHW	Write Data Hold Time	1	-	-	ns
tPWLW	Write Low Time	12	-	-	ns
tDHR	Read Data Hold Time	1	-	-	ns
tACC	Access Time	32	-	-	ns
tPWLr	Read Low Time	36	-	-	ns
tR	Rise Time	-	-	0.5	ns
tF	Fall Time	-	-	0.5	ns
tCS	Chip select setup time	2	-	-	ns
tCSH	Chip select hold time to read signal	3	-	-	ns

7.3. Parallel 8080-series Interface Timing Diagram(Write Cycle)

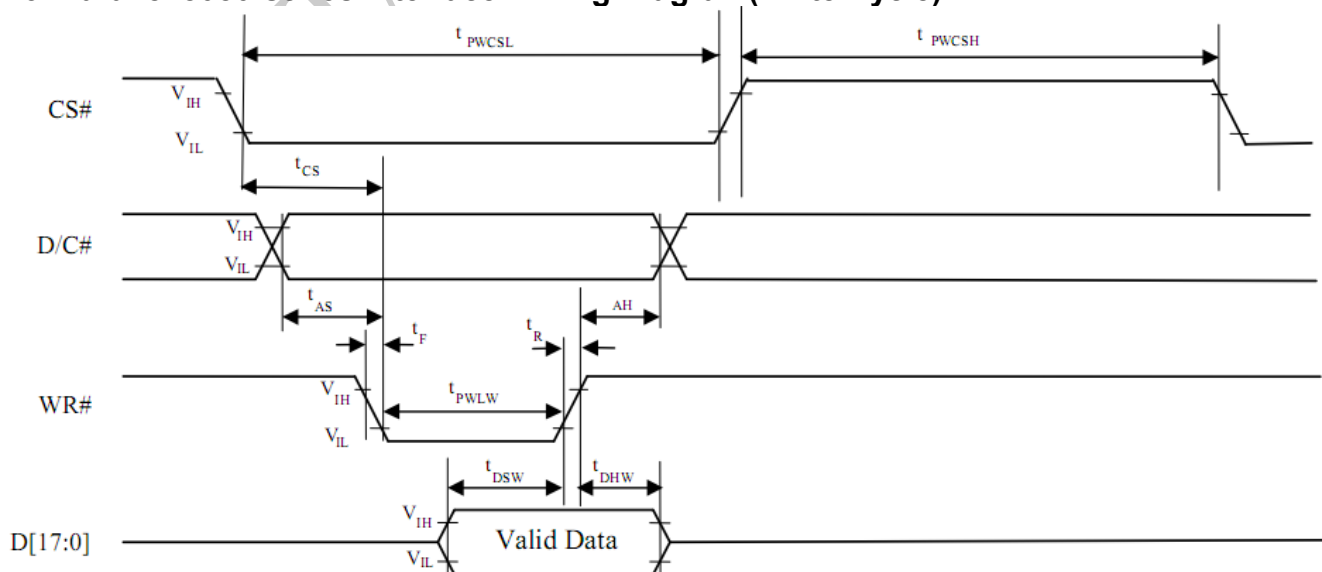

7.4. Parallel 8080-series Interface Timing Diagram(Read Cycle)

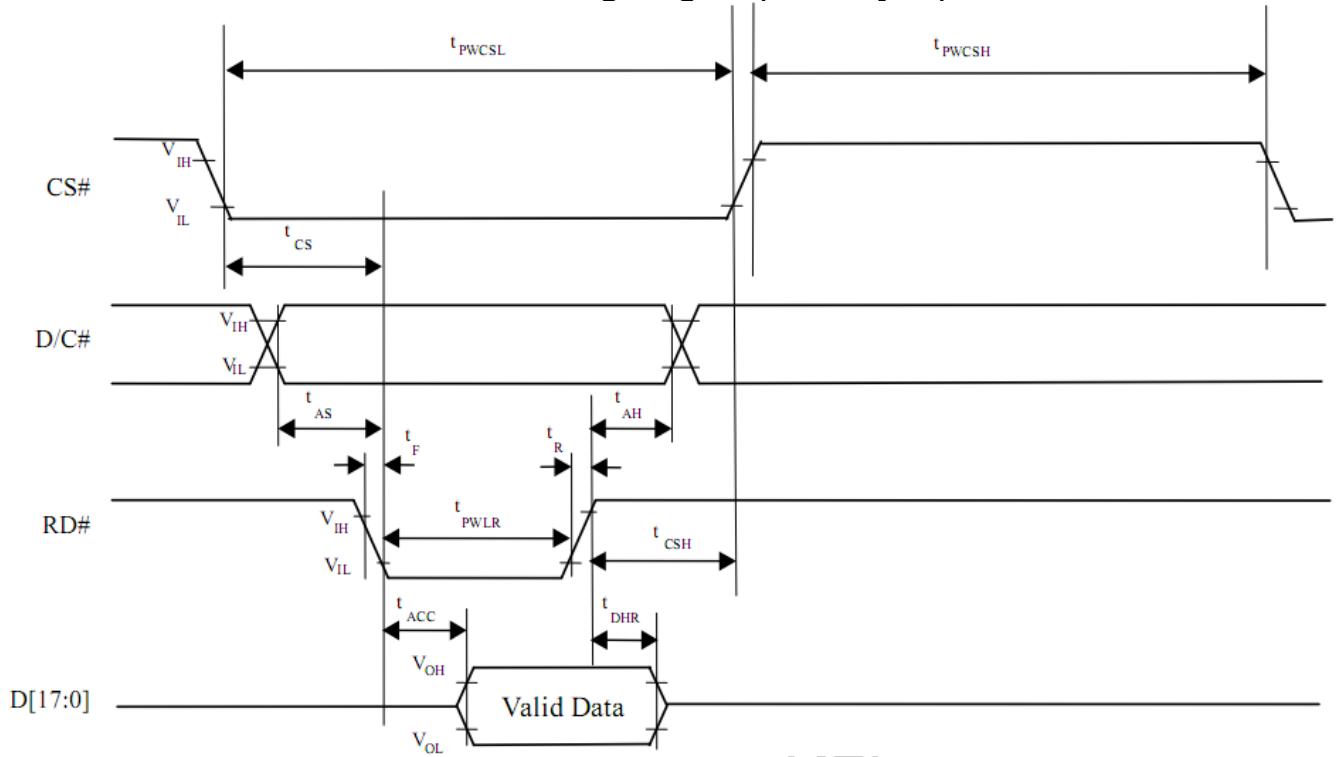

7.5. Pixel Data Format

Interface	Cycle	D[15]	D[14]	D[13]	D[12]	D[11]	D[10]	D[9]	D[8]	D[7]	D[6]	D[5]	D[4]	D[3]	D[2]	D[1]	D[0]
16 bits (565 format)	1 st	R5	R4	R3	R2	R1	G5	G4	G3	G2	G1	G0	B5	B4	B3	B2	B1
16 bits	1 st	R7	R6	R5	R4	R3	R2	R1	R0	G7	G6	G5	G4	G3	G2	G1	G0
	2 nd	B7	B6	B5	B4	B3	B2	B1	B0	R7	R6	R5	R4	R3	R2	R1	R0
	3 rd	G7	G6	G5	G4	G3	G2	G1	G0	B7	B6	B5	B4	B3	B2	B1	B0
8 bits	1 st									R7	R6	R5	R4	R3	R2	R1	R0
	2 nd									G7	G6	G5	G4	G3	G2	G1	G0
	3 rd									B7	B6	B5	B4	B3	B2	B1	B0

7.6. POWER SEQUENCE

Power-up Sequence

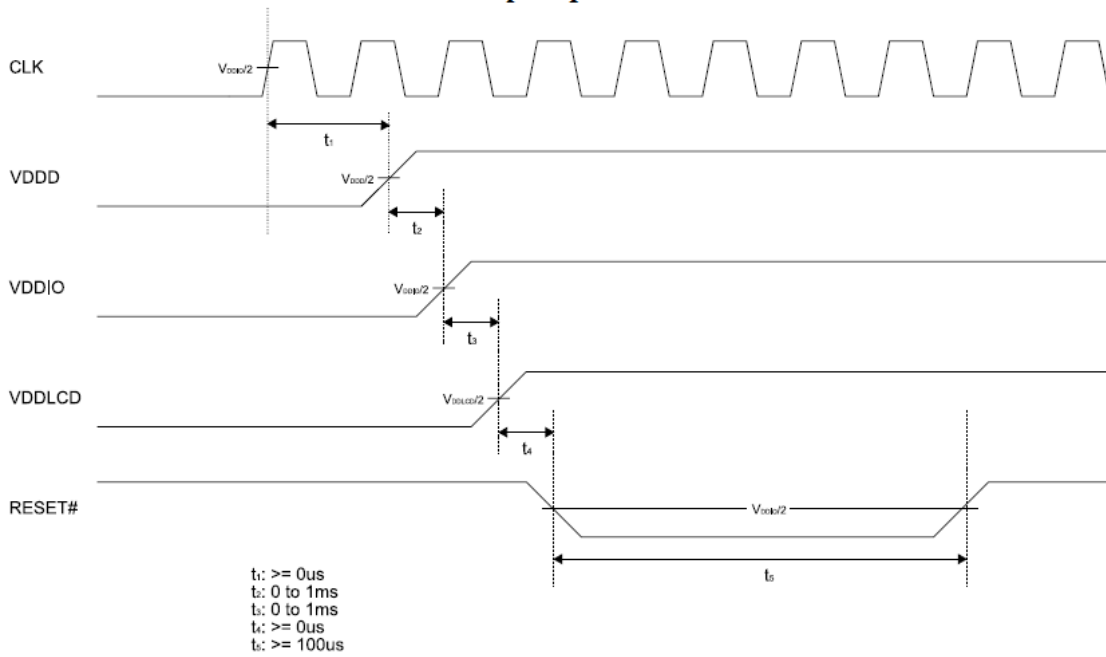

WINSTAR DISPLAY

8. Optical Characteristics

Item	Symbol	Condition.	Min	Typ.	Max.	Unit	Remark	
Response time	Tr+Tf	$\theta=0^\circ$ 、 $\phi=0^\circ$		25	-	.ms	Note 3	
Contrast ratio	CR	At optimized viewing angle	-	300	-	-	Note 4	
Color Chromaticity	White	Wx	$\theta=0^\circ$ 、 $\phi=0$	0.267	0.317	0.367		Note 2,6,7
		Wy		0.303	0.353	0.403		
Viewing angle (Gray Scale Inversion Direction)	Hor.	Θ_R	$CR \geq 10$	-	60	-	Deg.	Note 1
		Θ_L		-	60	-		
	Ver.	Φ_T		-	70	-		
		Φ_B		-	70	-		
Brightness	-	-	400	500	-	cd/m ²	Center of display	
Uniformity	(U)	-	75	-	-	%	Note 5	

Ta=25±2°C, IL=140mA

Note 1: Definition of viewing angle range

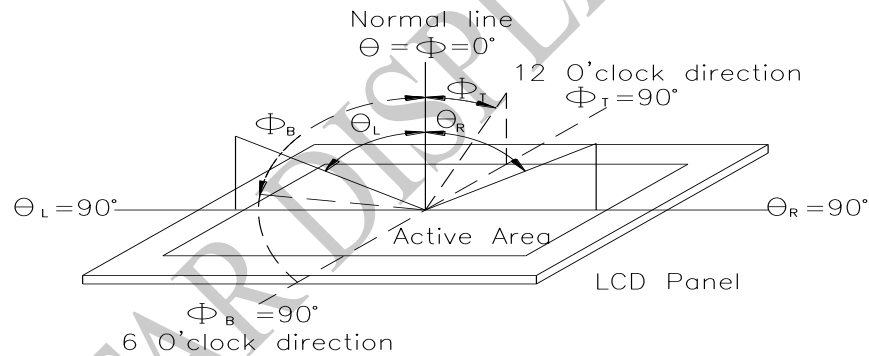

Fig. 8.1. Definition of viewing angle

Note 2: Test equipment setup:

After stabilizing and leaving the panel alone at a driven temperature for 10 minutes, the measurement should be executed. Measurement should be executed in a stable, windless, and dark room. Optical specifications are measured by Topcon BM-7 or BM-5 luminance meter 1.0° field of view at a distance of 50cm and normal direction.

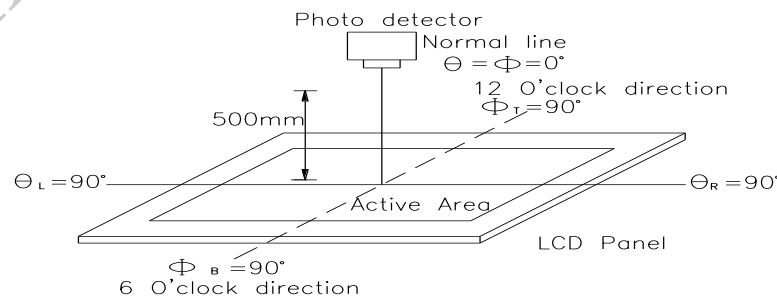
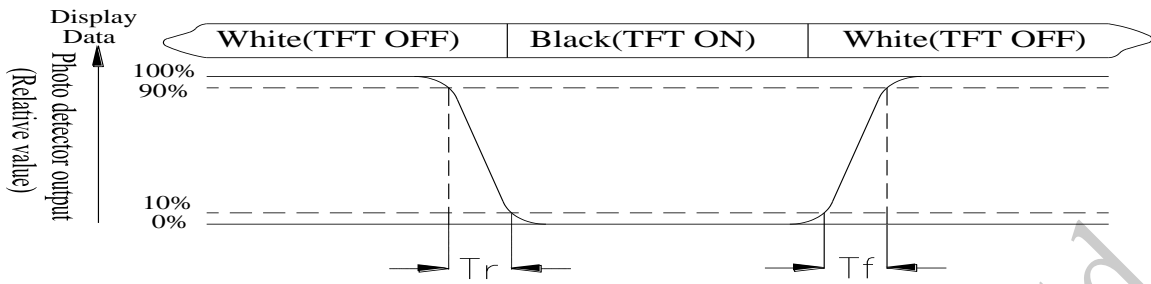

Fig. 8.2. Optical measurement system setup

Note 3: Definition of Response time:

The response time is defined as the LCD optical switching time interval between "White" state

and "Black" state. Rise time, T_r , is the time between photo detector output intensity changed from 90% to 10%. And fall time, T_f , is the time between photo detector output intensity changed from 10% to 90%



Note 4: Definition of contrast ratio:

The contrast ratio is defined as the following expression.

$$\text{Contrast ratio (CR)} = \frac{\text{Luminance measured when LCD on the "White" state}}{\text{Luminance measured when LCD on the "Black" state}}$$

Note 5: Definition of Luminance Uniformity

Active area is divided into 9 measuring areas (reference the picture in below). Every measuring point is placed at the center of each measuring area.

Luminance Uniformity (U) = $L_{\min}/L_{\max} \times 100\%$

L = Active area length

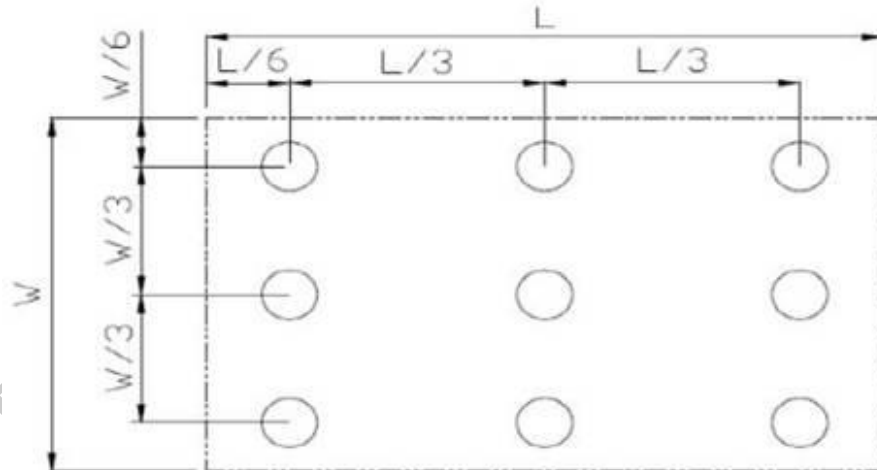

W = Active area width

Fig8.3. Definition of uniformity

Note 6: Definition of color chromaticity (CIE 1931)

Color coordinates measured at the center point of LCD

Note 7: Measured at the center area of the panel when all the input terminals of LCD panel are electrically opened.

9.Interface

9.1. LCM PIN Definition

Pin No.	Symbol	Description	Remark
1	GND	System ground pin of the IC.Connect to system ground.	
2	VDD	Power Supply : +3.3V	
3	NC	No connection	
4	D/C	Data/Command select	
5	WR	Write strobe signal	
6	RD	Read strobe signal	
7	DB0	Data bus	
8	DB1	Data bus	
9	DB2	Data bus	
10	DB3	Data bus	
11	DB4	Data bus	
12	DB5	Data bus	
13	DB6	Data bus	
14	DB7	Data bus	
15	CS	Chip select	
16	RST	Hardware reset	Note 1
17	NC	No connection	
18	RL	Left /right selection; Scan Direction; Default RL=H	Note 2,3
19	UD	Up/down selection; Scan Direction; Default UD=L	Note 2,3
20	NC	No connection	

Note 1: Global reset pin. Active low to enter reset state. Suggest to connect with an RC reset circuit for stability. Normally pull high.

Note 2: Selection of scanning mode

Setting of scan control input		Scanning direction
UD	LR	
L	H	Up to down, left to right
H	L	Down to up, right to left
L	L	Up to down, right to left
H	H	Down to up, left to right

Note3: Definition of scanning direction.Refer to the figure as below:



UD=L, LR=H

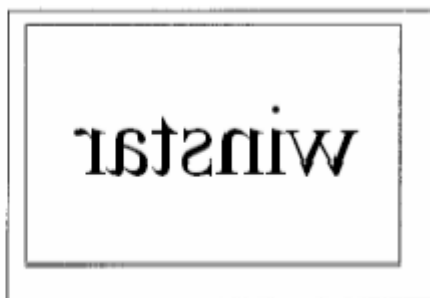

UD=L, LR=L

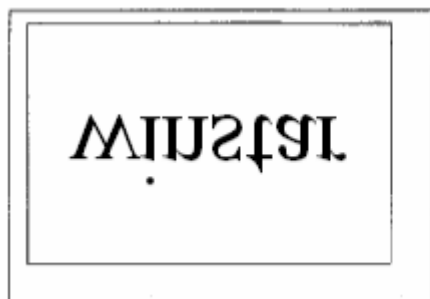

UD=H, LR=H

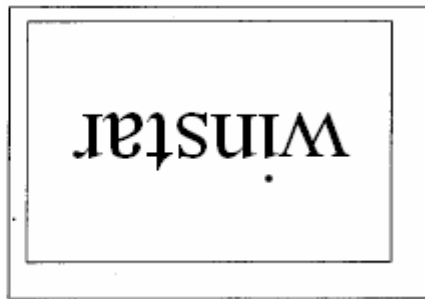

UD=H, LR=L

WINSTAR DISPLAY Ltd.

10. Block Diagram

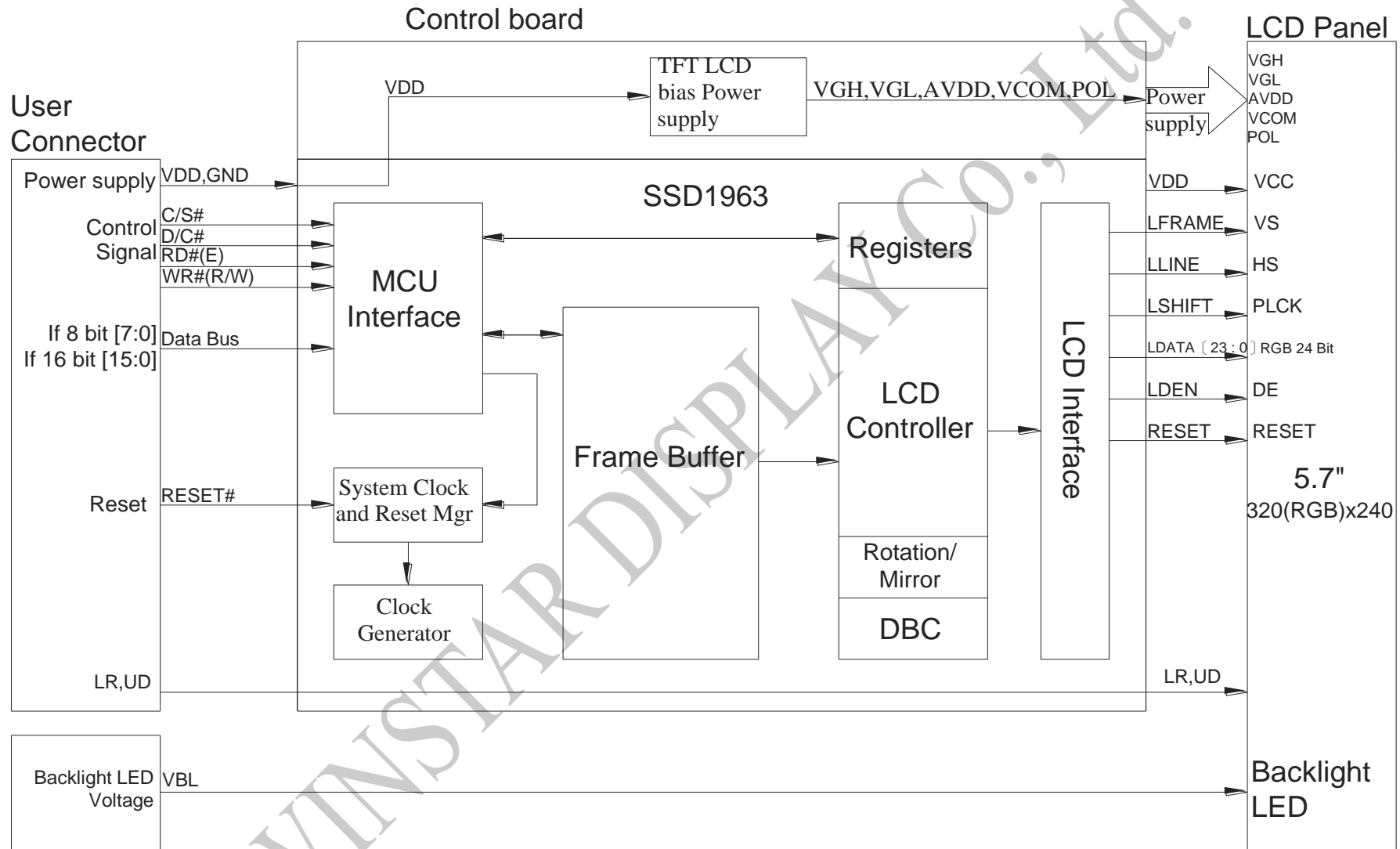

11. Reliability

Content of Reliability Test (Wide temperature, -20°C~70°C)

Environmental Test			
Test Item	Content of Test	Test Condition	Note
High Temperature storage	Endurance test applying the high storage temperature for a long time.	80°C 200hrs	2
Low Temperature storage	Endurance test applying the low storage temperature for a long time.	-30°C 200hrs	1,2
High Temperature Operation	Endurance test applying the electric stress (Voltage & Current) and the thermal stress to the element for a long time.	70°C 200hrs	—
Low Temperature Operation	Endurance test applying the electric stress under low temperature for a long time.	-20°C 200hrs	1
High Temperature/ Humidity Operation	The module should be allowed to stand at 60°C,90%RH max	60°C,90%RH 96hrs	1,2
Thermal shock resistance	The sample should be allowed stand the following 10 cycles of operation <div style="text-align: center;"> <p style="text-align: center;">-20°C 25°C 70°C</p> <p style="text-align: center;">30min 5min 30min</p> <p style="text-align: center;">1 cycle</p> </div>	-20°C/70°C 10 cycles	—
Vibration test	Endurance test applying the vibration during transportation and using.	Total fixed amplitude : 1.5mm Vibration Frequency : 10~55Hz One cycle 60 seconds to 3 directions of X,Y,Z for Each 15 minutes	3
Static electricity test	Endurance test applying the electric stress to the terminal.	VS=±600V(contact), ±800v(air), RS=330Ω CS=150pF 10 times	—

Note1: No dew condensation to be observed.

Note2: The function test shall be conducted after 4 hours storage at the normal Temperature and humidity after remove from the test chamber.

Note3: The packing have to including into the vibration testing.

12. Contour Drawing

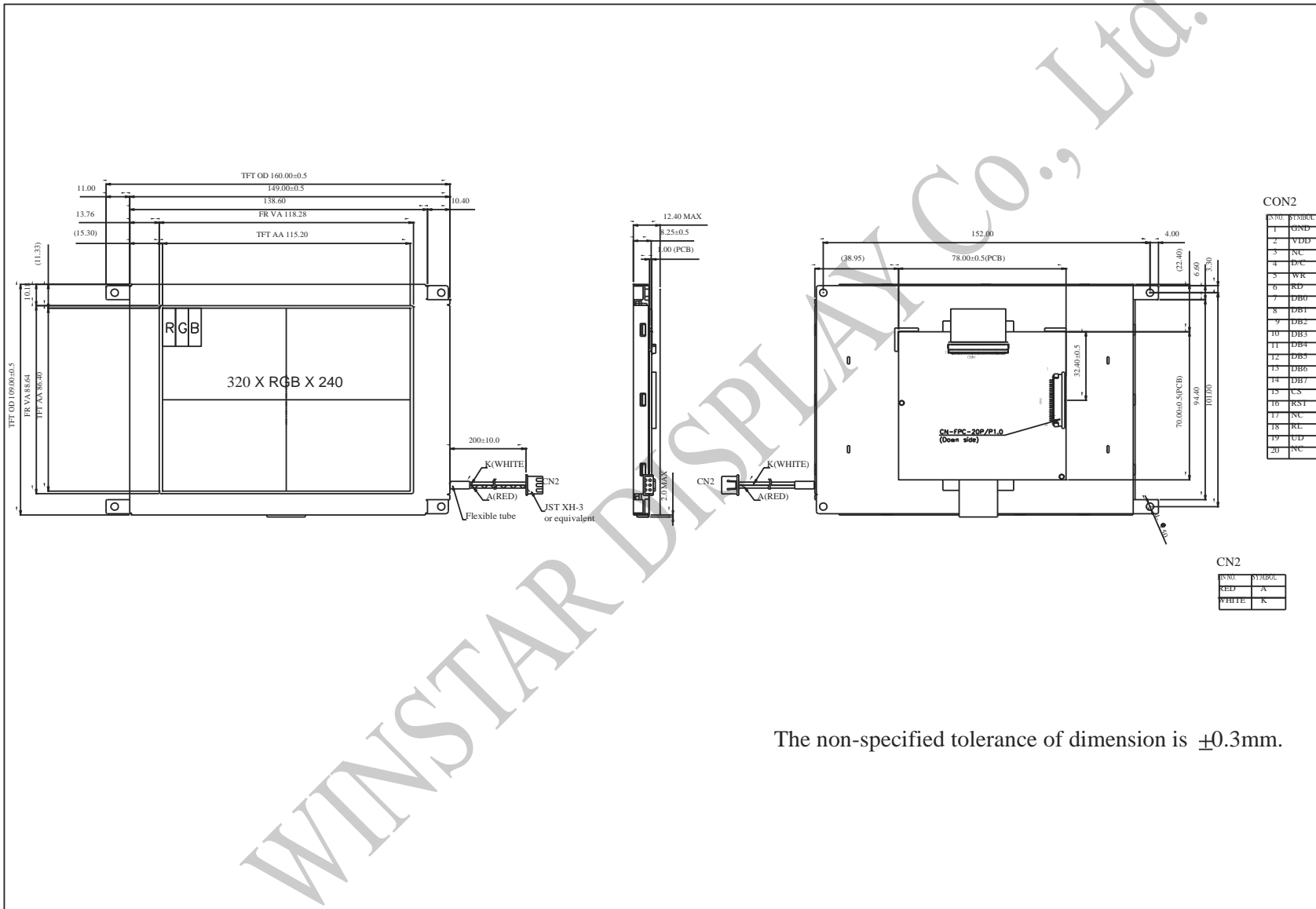

The non-specified tolerance of dimension is $\pm 0.3\text{mm}$.

13.Initial Code For Reference

```
void Initial_SSD1963()
{
    Write_Command(0x01);
    Delay_ms(10);
    Write_Command(0xe0);
    Write_Parameter(0x01);
    Delay_ms(50);
    Write_Command(0xe0);
    Write_Parameter(0x03);
    Delay_ms(5);

    Write_Command(0xb0);
    Write_Parameter(0x0c);
    Write_Parameter(0x80);
    Write_Parameter(0x01);
    Write_Parameter(0x3f);
    Write_Parameter(0x00);
    Write_Parameter(0xef);
    Write_Parameter(0x00);

    Write_Command(0xf0);
    Write_Parameter(0x03);

    Write_Command(0xe2);
    Write_Parameter(0x1d);
    Write_Parameter(0x02);
    Write_Parameter(0x54);

    Write_Command(0xe6);
    Write_Parameter(0x01);
    Write_Parameter(0x40);
    Write_Parameter(0xff);

    Write_Command(0xb4);
    Write_Parameter(0x01);
    Write_Parameter(0xb8);
    Write_Parameter(0x00);
    Write_Parameter(0x44);
    Write_Parameter(0x07);
    Write_Parameter(0x00);
    Write_Parameter(0x00);
    Write_Parameter(0x00);

    Write_Command(0xb6);
    Write_Parameter(0x01);
```

Write_Parameter(0x08);
Write_Parameter(0x00);
Write_Parameter(0x13);
Write_Parameter(0x07);
Write_Parameter(0x00);
Write_Parameter(0x00);

Write_Command(0x2a);
Write_Parameter(0x00);
Write_Parameter(0x00);
Write_Parameter(0x01);
Write_Parameter(0x3f);

Write_Command(0x2b);
Write_Parameter(0x00);
Write_Parameter(0x00);
Write_Parameter(0x00);
Write_Parameter(0xef);

Write_Command(0x29);
Write_Command(0x2c);

}

WINSTAR DISPLAY Co., Ltd.



1、Panel Specification :

- 1. Panel Type : Pass NG , _____
- 2. View Direction : Pass NG , _____
- 3. Numbers of Dots : Pass NG , _____
- 4. View Area : Pass NG , _____
- 5. Active Area : Pass NG , _____
- 6. Operating : Pass NG , _____
- 7. Storage Temperature : Pass NG , _____
- 8. Others : _____

2、Mechanical

- 1. PCB Size : Pass NG , _____
- 2. Frame Size : Pass NG , _____
- 3. Material of Frame : Pass NG , _____
- 4. Connector Position : Pass NG , _____
- 5. Fix Hole Position : Pass NG , _____
- 6. Backlight Position : Pass NG , _____
- 7. Thickness of PCB : Pass NG , _____
- 8. Height of Frame to PCB : Pass NG , _____
- 9. Height of Module : Pass NG , _____
- 10. Others : Pass NG , _____

3、Relative Hole Size :

- 1. Pitch of Connector : Pass NG , _____
- 2. Hole size of Connector : Pass NG , _____
- 3. Mounting Hole size : Pass NG , _____
- 4. Mounting Hole Type : Pass NG , _____
- 5. Others : Pass NG , _____

4、Backlight Specification :

- 1. B/L Type : Pass NG , _____
- 2. B/L Color : Pass NG , _____
- 3. B/L Driving Voltage (Reference for LED) Pass NG , _____
- 4. B/L Driving Current : Pass NG , _____
- 5. Brightness of B/L : Pass NG , _____
- 6. B/L Solder Method : Pass NG , _____
- 7. Others : Pass NG , _____

>> **Go to page 2** <<



5、Electronic Characteristics of Module :

- 1. Input Voltage : Pass NG , _____
- 2. Supply Current : Pass NG , _____
- 3. Driving Voltage for LCD : Pass NG , _____
- 4. Contrast for LCD : Pass NG , _____
- 5. B/L Driving Method : Pass NG , _____
- 6. Negative Voltage Output : Pass NG , _____
- 7. Interface Function : Pass NG , _____
- 8. LCD Uniformity : Pass NG , _____
- 9. ESD test : Pass NG , _____
- 10. Others : Pass NG , _____

6、Summary :

Sales signature : _____

Customer Signature : _____

Date : / / _____

