

**Recommended PCB Layout**

General Tolerance ±0.05

▨ Solder Area □ Component Outline

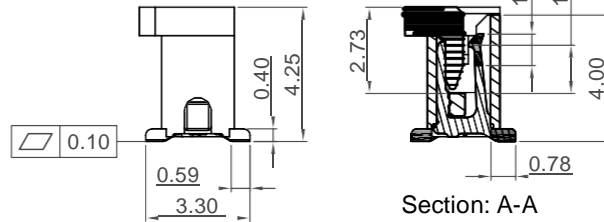
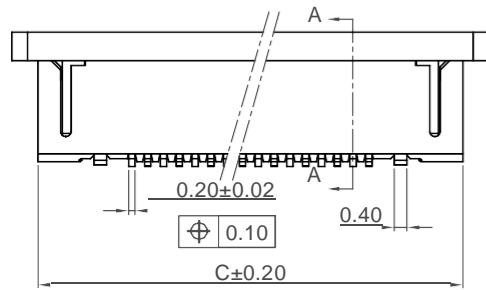

**Section: A-A**

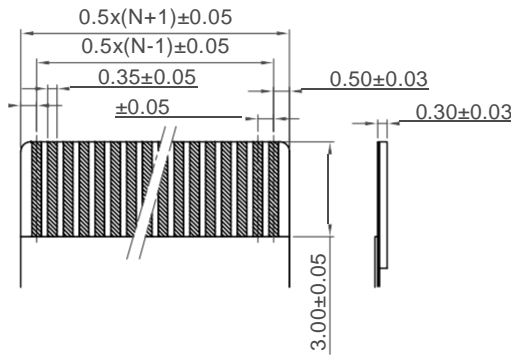
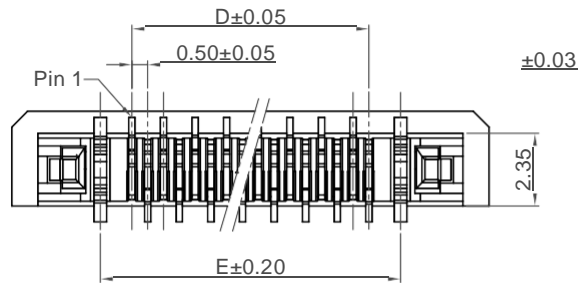

**Recommended FFC/FPC Dimensions**

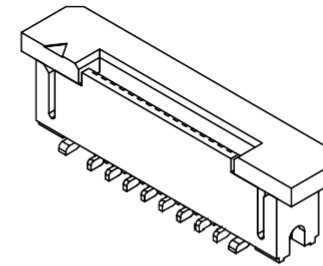

**Specifications**

**Material**

Housing: LCP,UL 94V-0, Natural  
 Actuator: LCP,UL 94V-0, Black  
 Contact: Phosphor Bronze,T=0.2mm  
 Fitting Nail: Brass,T=0.4mm

**Plating**

Contact: see ordering grid  
 Fitting Nail: Sn Plating over Nickel

**Electrical**

Voltage Rating: 30V  
 Current Rating : 0.2A  
 Dielectric Strength: 250V AC for 1 minute  
 Insulation Resistance: 50 MΩ Min.  
 Contact Resistance: 40 mΩ Max.

**Mechanical & Environmental**

Durability: 20 Cycles  
 Operating Temperature: -25°C to +85°C  
 Solder Profile:  
 Peak Temp 260°C (+0/-5°C) max. (5 seconds)

**Ordering Grid**

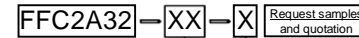

No. of Contacts

04 - 60

(see dimension table)

**Contact Plating**

T= Tin Plating over all (Standard)

G= Gold Flash over all

No. of Contacts	Dimensions				
	A	B	C	D	E
4	9.10	2.60	7.45	1.50	3.50
5	9.60	3.10	7.95	2.00	4.00
* 6	10.10	3.60	8.45	2.50	4.50
7	10.60	4.10	8.95	3.00	5.00
* 8	11.10	4.60	9.45	3.50	5.50
9	11.60	5.10	9.95	4.00	6.00
* 10	12.10	5.60	10.45	4.50	6.50
11	12.60	6.10	10.95	5.00	7.00
* 12	13.10	6.60	11.45	5.50	7.50
13	13.60	7.10	11.95	6.00	8.00
14	14.10	7.60	12.45	6.50	8.50
15	14.60	8.10	12.95	7.00	9.00
* 16	15.10	8.60	13.45	7.50	9.50
17	15.60	9.10	13.95	8.00	10.00
18	16.10	9.60	14.45	8.50	10.50
19	16.60	10.10	14.95	9.00	11.00
* 20	17.10	10.60	15.45	9.50	11.50
* 21	17.60	11.10	15.95	10.00	12.00
22	18.10	11.60	16.45	10.50	12.50
23	18.60	12.10	16.95	11.00	13.00
* 24	19.10	12.60	17.45	11.50	13.50
25	19.60	13.10	17.95	12.00	14.00
* 26	20.10	13.60	18.45	12.50	14.50
27	20.60	14.10	18.95	13.00	15.00
28	21.10	14.60	19.45	13.50	15.50
29	21.60	15.10	19.95	14.00	16.00
* 30	22.10	15.60	20.45	14.50	16.50
31	22.60	16.10	20.95	15.00	17.00
* 32	23.10	16.60	21.45	15.50	17.50
33	23.60	17.10	21.95	16.00	18.00
* 34	24.10	17.60	22.45	16.50	18.50
35	24.60	18.10	22.95	17.00	19.00
* 36	25.10	18.60	23.45	17.50	19.50
37	25.60	19.10	23.95	18.00	20.00
38	26.10	19.60	24.45	18.50	20.50
39	26.60	20.10	24.95	19.00	21.00
* 40	27.10	20.60	25.45	19.50	21.50
41	27.60	21.10	25.95	20.00	22.00
42	28.10	21.60	26.45	20.50	22.50
43	28.60	22.10	26.95	21.00	23.00
44	29.10	22.60	27.45	21.50	23.50
* 45	29.60	23.10	27.95	22.00	24.00
46	30.10	23.60	28.45	22.50	24.50
47	30.60	24.10	28.95	23.00	25.00
48	31.10	24.60	29.45	23.50	25.50
49	31.60	25.10	29.95	24.00	26.00
* 50	32.10	25.60	30.45	24.50	26.50
51	32.60	26.10	30.95	25.00	27.00
52	33.10	26.60	31.45	25.50	27.50
53	33.60	27.10	31.95	26.00	28.00
54	34.10	27.60	32.45	26.50	28.50
55	34.60	28.10	32.95	27.00	29.00
56	35.10	28.60	33.45	27.50	29.50
57	35.60	29.10	33.95	28.00	30.00
58	36.10	29.60	34.45	28.50	30.50
59	36.60	30.10	34.95	29.00	31.00
* 60	37.10	30.60	35.45	29.50	31.50

\* = Tooled Parts  
 Please contact GCT for non-tooled parts

Part Number		Product Description	
FFC2A32		FPC 0.5mm Pitch Top Entry, SMT, Right Footprint, Height=4.25mm, ZIF, Slide Type	
Drawing Date		12th September 2019	
By	CC	Tolerances (Except as Noted)	Units:
Detail	Drawing Release	Length	Metric (mm)
Revision	A1	X. ± 0.50	3rd Angle Projection
Date	24/10/19	X.X ± 0.30	
		X.XX ± 0.20	
		X.XXX ± 0.10	± 0.5°



This drawing is confidential and copyright of Global Connector Technology, Ltd (GCT). This drawing must not be copied or disclosed without written consent. E & OE



Not to Scale Drawn By CC Sheet No. 1/2

H  
G  
F  
E  
D  
C  
B  
A

H  
G  
F  
E  
D  
C  
B  
A

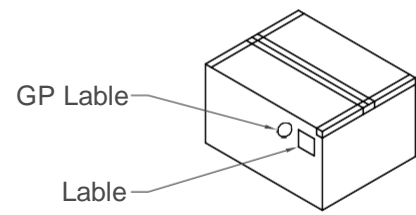
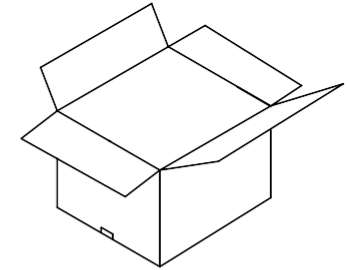
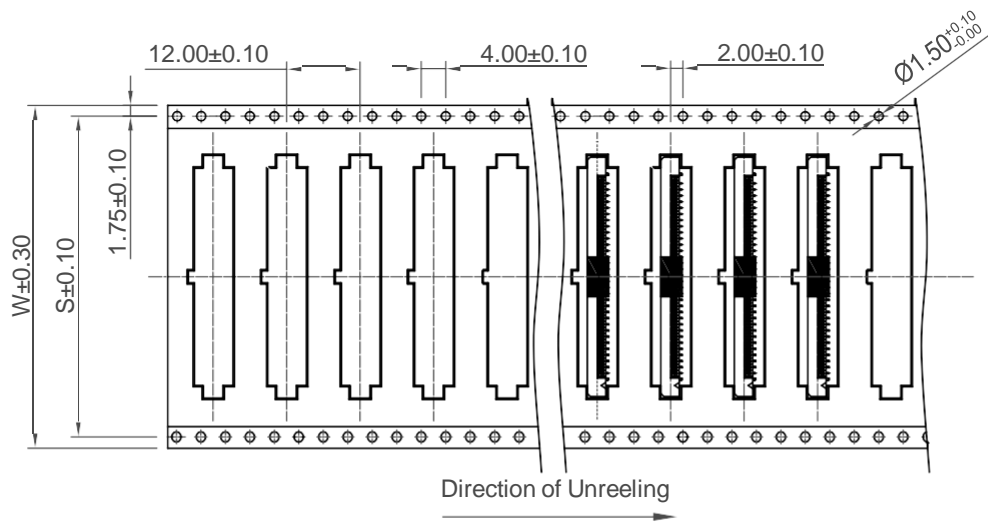
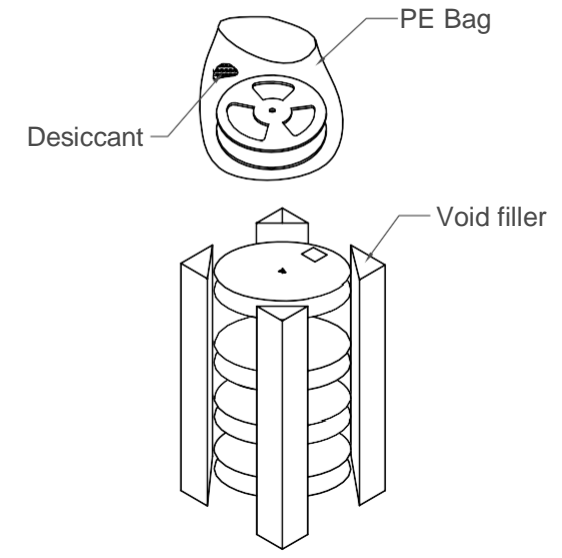
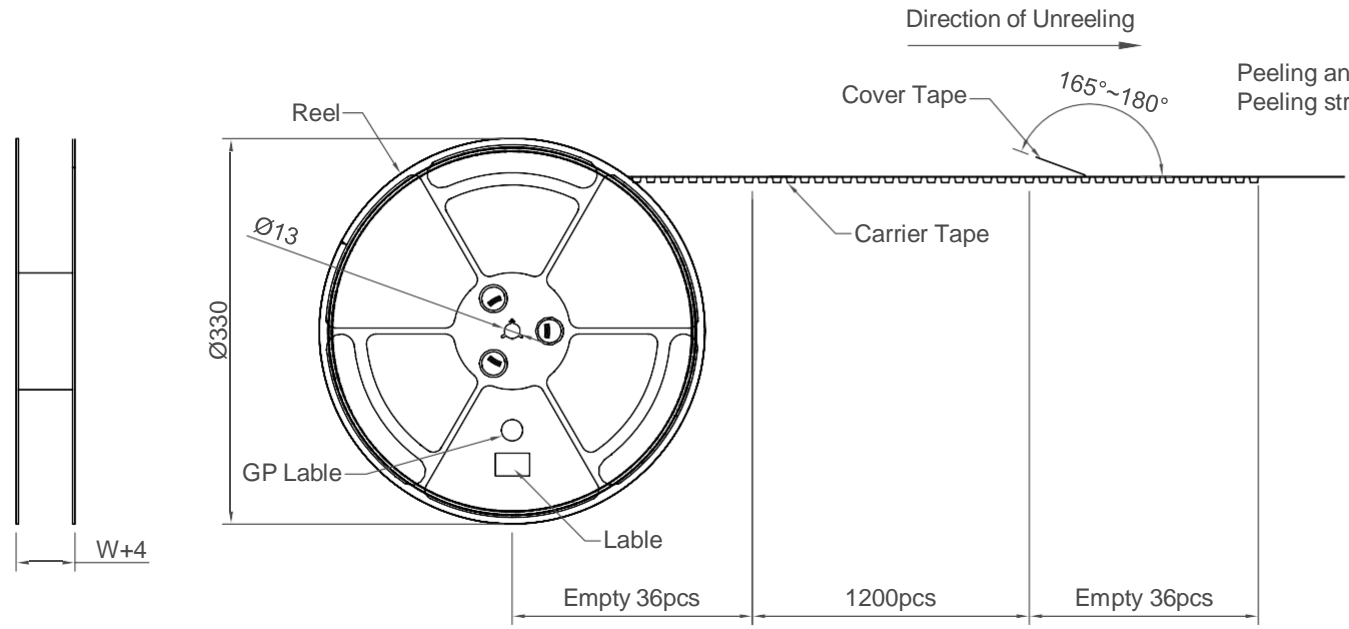

No. of Contacts	W	S	Pcs/Reel	Reel/Carton	Pcs/Carton
4 ~ 15	24	/	1200	10	12000
16 ~ 25	32	28.4	1200	8	9600
26 ~ 50	44	40.4	1200	6	7200
51 ~ 60	56	52.4	1200	4	4800

Part Number		Product Description	
FFC2A32		FFC 0.5mm Pitch Top Entry, SMT, Right Footprint, Height=4.25mm, ZIF, Slide Type	
Drawing Date		12th September 2019	
By	CC	Tolerances (Except as Noted)	Units:
Detail	Drawing Release	Length	Metric (mm)
Revision	A1	Angle	3rd Angle Projection
Date	24/10/19		



This drawing is confidential and copyright of Global Connector Technology, Ltd (GCT). This drawing must not be copied or disclosed without written consent. E & OE



Not to Scale	Drawn By CC	Sheet No. 2/2
--------------	-------------	---------------

1 2 3 4 5 6 7 8

