

Series 801 Mighty Mouse Double-Start ACME Thread Right Angle PCB Header Receptacle with PC tails

801-023 Ordering Information

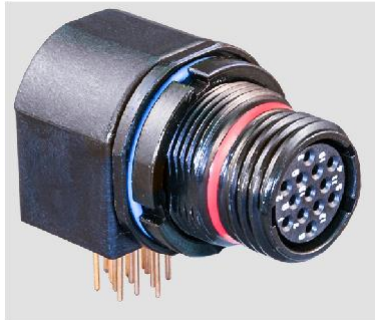

Series 801



Right Angle Printed Circuit Board Receptacle Feature a double-start modified stub ACME mating thread for improved protection against cross-mating and thread damage. High temperature thermoplastic housing withstands soldering temperatures while reducing weight. Stainless steel threaded inserts simplify attachment to printed circuit board.

- ❑ Double-Start ACME Thread
- ❑ Right Angle PCB Receptacle
- ❑ High Temperature Housing
- ❑ Threaded Inserts
- ❑ Environmentally Sealed

How To Order	
Sample Part Number	801-023 -07 M 7-10 P A
Series	801-023 = PCB Right Angle Header Receptacle
Shell Style	-07 = Jam-Nut, Rear Panel Mount
Material and Finish	C = Aluminum / Black Anodize (Non-Conductive) M = Aluminum / Electroless Nickel MT = Aluminum / Nickel-PTFE NF = Aluminum / Cadmium with Olive Drab Chromate ZNU = Aluminum / Zinc-Nickel with Black Chromate Z1 = Stainless Steel / Passivated
Shell Size - Insert Arrangement	5-3, 6-1, 6-23, 6-4, 6-6, 6-7, 7-1, 7-25, 7-10, 8-2, 8-28, 8-13, 9-4, 9-210, 9-19, 9-200, 10-2, 10-5, 10-201
Contact Type	P = Pin S = Socket
Polarization (See Table I)	A = Normal B = Pos. B C = Pos. C D = Pos. D E = Pos. E F = Pos. F G = Pos. G H = Pos. H J = Pos. J

NOTES

- Torque 2-56 screws to 20-25 in/oz with Loc-Tite recommended
- For shell sizes 5-8, 2-56 start of thread is .100 +.000/-.050 below surface and mounting hole depth is .300
For Shell sizes 9 & 10, 2-56 start of thread is .150 and mounting hole depth is .350
- Master keyway is located at top dead center for all arrangements except for the 8-13, which is 90° counter clockwise from top center.

Material / finish:

- Shell, jam-nut: aluminum alloy or CRES
- Insulator: LCP or epoxy
- Interfacial seal, O-ring: fluorosilicone/N.A.
- Contact: copper alloy / gold plate per ASTM B 488, Type II, Code C, Class 1.25 (.00005 minimum thickness), over a suitable underplate
- Potting: epoxy

Table I: Keyway Positions

Position	A°	B°
A	150°	210°
B	75°	210°
C	95°	230°
D	140°	275°
E	75°	275°
F	95°	210°

Jam-Nut Panel Cutout

Shell Size	A Flat	Ø B
	+ .004 (+.10) - .000 (-.00)	+ .005 (+.13) - .000 (-.00)
5	.354 (8.99)	.380 (9.65)
6	.414 (10.52)	.443 (11.25)
7	.540 (13.72)	.567 (14.40)
8	.540 (13.74)	.567 (14.40)
9	.600 (15.24)	.630 (16.00)
10	.662 (16.81)	.693 (17.60)

Dimensions in Inches (millimeters) are subject to change without notice.

Jam-nut, rear panel mount - shell style 07

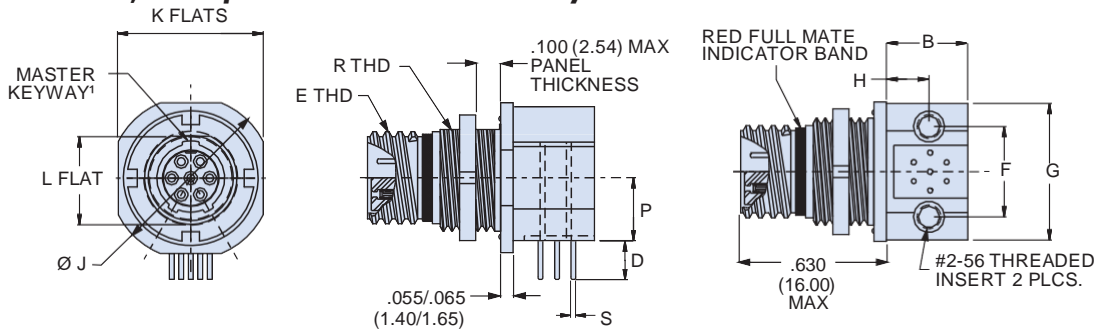

PC Tail Dimensions	
Contact Size	Ø S
#23	Ø .018 / .022
#20	Ø .028 / .024
#16	Ø .060 / .064
#12	Ø .092 / .096

Dimensions

Shell Size	B	D ±.035	E Thread	F	G	H	Ø J	K Flat	L Flat	P	R Thread
5-3	.260 (6.60)	.275 (6.99)	.3125-.05P-.1L-DS- 2A	.310 (7.87)	.490 (12.45)	.165 (4.19)	.580 (14.73)	.545 (13.84)	.355 (9.02) .346 (8.79)	.225 (5.72)	.375-28 UN-2A
6-1	.345 (8.76)	.292 (7.42)	.3750-.05P-.1L-DS- 2A	.385 (9.78)	.589 (14.96)	.224 (5.69)	.635 (16.13)	.602 (15.29)	.415 (10.54) .406 (10.31)	.225 (5.72)	.4375-28 UNEF-2A
6-23	.345 (8.76)	.305 (7.75)	.3750-.05P-.1L-DS- 2A	.385 (9.78)	.589 (14.96)	.224 (5.69)	.635 (16.13)	.602 (15.29)	.415 (10.54) .406 (10.31)	.225 (5.72)	.4375-28 UNEF-2A
6-4	.345 (8.76)	.292 (7.42)	.3750-.05P-.1L-DS-2A	.385 (9.78)	.589 (14.96)	.224 (5.69)	.635 (16.13)	.602 (15.29)	.415 (10.54) .406 (10.31)	.225 (5.72)	.4375-28 UNEF-2A
6-6, 6-7	.345 (8.76)	.265 (6.73)	.3750-.05P-.1L-DS-2A	.408 (10.36)	.589 (14.96)	.187 (4.75)	.635 (16.13)	.602 (15.29)	.415 (10.54) .406 (10.31)	.225 (5.72)	.4375-28 UNEF-2A
7-1	.345 (8.76)	.273 (6.93)	.4375-.05P-.1L-DS- 2A	.452 (11.48)	.710 (18.03)	.170 (4.32)	.755 (19.18)	.723 (18.36)	.539 (13.69) .530 (13.46)	.296 (7.52)	.5625-32 UN-2A
7-25	.345 (8.76)	.266 (6.76)	.4375-.05P-.1L-DS- 2A	.452 (11.48)	.710 (18.03)	.170 (4.32)	.755 (19.18)	.723 (18.36)	.539 (13.69) .530 (13.46)	.296 (7.52)	.5625-32 UN-2A
7-10	.345 (8.76)	.273 (6.93)	.4375-.05P-.1L-DS-2A	.452 (11.48)	.710 (18.03)	.170 (4.32)	.755 (19.18)	.723 (18.36)	.539 (13.69) .530 (13.46)	.296 (7.52)	.5625-32 UN-2A
8-2	.490 (12.45)	.305 (7.75)	.5000-.05P-.1L-DS- 2A	.490 (12.45)	.710 (18.03)	.230 (5.84)	.755 (19.18)	.723 (18.36)	.539 (13.69) .530 (13.46)	.320 (8.13)	.5625-32 UN-2A
8-28	.490 (12.45)	.289 (7.34)	.5000-.05P-.1L-DS- 2A	.490 (12.45)	.710 (18.03)	.230 (5.84)	.755 (19.18)	.723 (18.36)	.539 (13.69) .530 (13.46)	.320 (8.13)	.5625-32 UN-2A
8-13	.490 (12.45)	.305 (7.75)	.5000-.05P-.1L-DS-2A	.490 (12.45)	.710 (18.03)	.230 (5.84)	.755 (19.18)	.723 (18.36)	.539 (13.69) .530 (13.46)	.320 (8.13)	.5625-32 UN-2A
9-4	.490 (12.45)	.240 (6.10)	.5625-.05P-.1L-DS- 2A	.600 (15.24)	.800 (20.32)	.342 (8.69)	.830 (21.08)	.790 (20.07)	.601 (15.27) .592 (15.04)	.362 (9.19)	.6250-28 UN-2A
9-210	.490 (12.45)	.245 (6.22)	.5625-.05P-.1L-DS- 2A	.600 (15.24)	.800 (20.32)	.342 (8.69)	.830 (21.08)	.790 (20.07)	.601 (15.27) .592 (15.04)	.362 (9.19)	.6250-28 UN-2A
9-19	.490 (12.45)	.275 (6.99)	.5625-.05P-.1L-DS-2A	.600 (15.24)	.800 (20.32)	.342 (8.69)	.830 (21.08)	.790 (20.07)	.601 (15.27) .592 (15.04)	.362 (9.19)	.6250-28 UN-2A
9-200	.490 (12.45)	.255 (6.48)	.5625-.05P-.1L-DS- 2A	.600 (15.24)	.800 (20.32)	.342 (8.69)	.830 (21.08)	.790 (20.07)	.601 (15.27) .592 (15.04)	.362 (9.19)	.6250-28 UN-2A
10-2	.570 (14.48)	.299 (7.59)	.6250-.05P-.1L-DS- 2A	.640 (16.26)	.840 (21.34)	.362 (9.19)	.890 (22.61)	.855 (21.72)	.663 (16.84) .654 (16.61)	.397 (10.08)	.6875-28 UN-2A
10-5	.570 (14.48)	.255 (6.48)	.6250-.05P-.1L-DS- 2A	.640 (16.26)	.840 (21.34)	.362 (9.19)	.890 (22.61)	.855 (21.72)	.663 (16.84) .654 (16.61)	.397 (10.08)	.6875-28 UN-2A
10-201	.570 (14.48)	.294 (7.47)	.6250-.05P-.1L-DS- 2A	.640 (16.26)	.840 (21.34)	.362 (9.19)	.890 (22.61)	.855 (21.72)	.663 (16.84) .654 (16.61)	.397 (10.08)	.6875-28 UN-2A

Dimensions in Inches (millimeters) are subject to change without notice.

Series 801 Mighty Mouse Double-Start ACME Thread Right Angle PCB Receptacle

801-023 PCB Footprints, Socket Connectors



Series 801

RIGHT ANGLE PCB FOOTPRINTS, SOCKET CONNECTORS

Patterns shown are for component mounting side of PCB.

#23=.022 max #20=.028 #16=.064 #12=.096, mounting holes are .093 (2.36) diameter

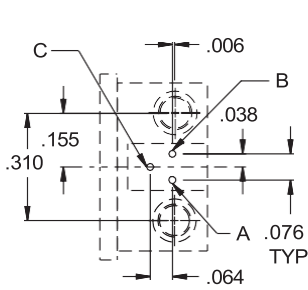

ARRANGEMENT NO. 5-3
(3 #23 CONTACTS)

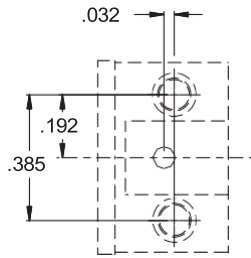

ARRANGEMENT NO. 6-1
(1 #16 CONTACT)

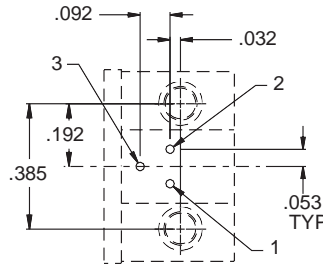

ARRANGEMENT NO. 6-23
(3 #20HD CONTACTS)

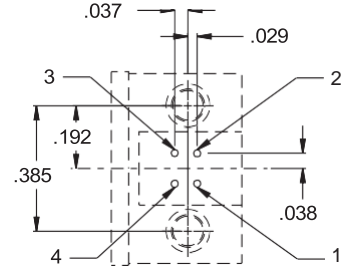

ARRANGEMENT NO. 6-4
(4 #23 CONTACTS)

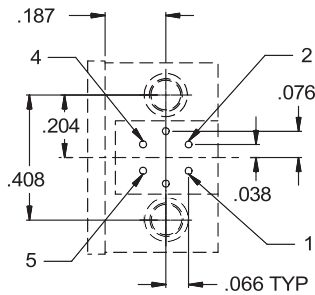

ARRANGEMENT NO. 6-6
(6 #23 CONTACTS)

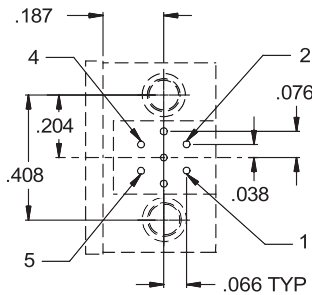

ARRANGEMENT NO. 6-7
(7 #23 CONTACTS)

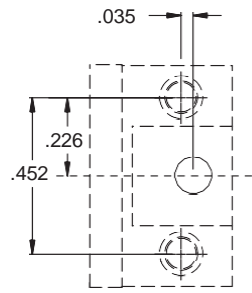

ARRANGEMENT NO. 7-1
(1 #12 CONTACT)

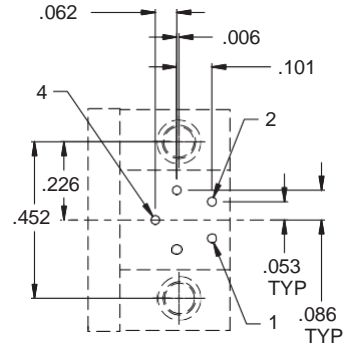

ARRANGEMENT NO. 7-25
(5 #20HD CONTACTS)

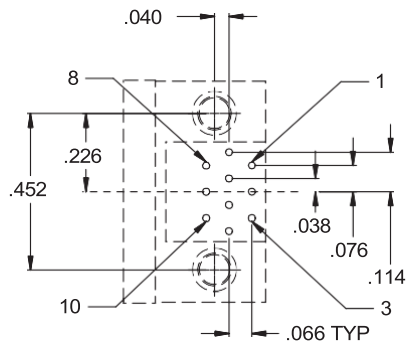

ARRANGEMENT NO. 7-10
(10 #23 CONTACTS)

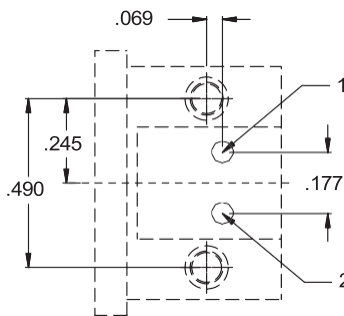

ARRANGEMENT NO. 8-2
(2 #16 CONTACTS)

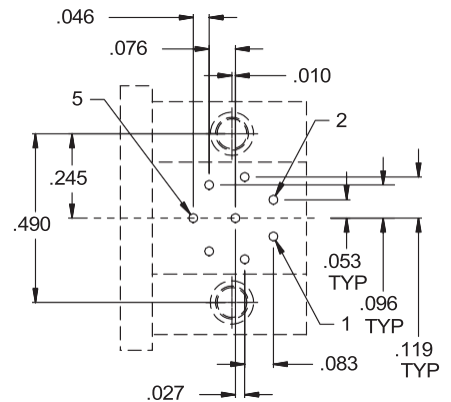

ARRANGEMENT NO. 8-28
(8 #20HD CONTACTS)

Dimensions in Inches (millimeters) are subject to change without notice.



Series 801 Mighty Mouse Double-Start ACME Thread Right Angle PCB Receptacle 801-023 PCB Footprints, Socket Connectors

RIGHT ANGLE PCB FOOTPRINTS, SOCKET CONNECTORS

Patterns shown are for component mounting side of PCB.

#23=.022 max #20=.028 #16=.064 #12=.096, mounting holes are .093 (2.36) diameter

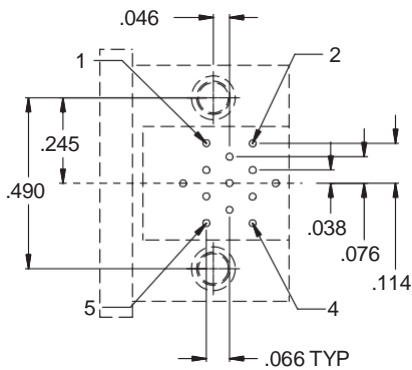

ARRANGEMENT NO. 8-13
(13 #23 CONTACTS)

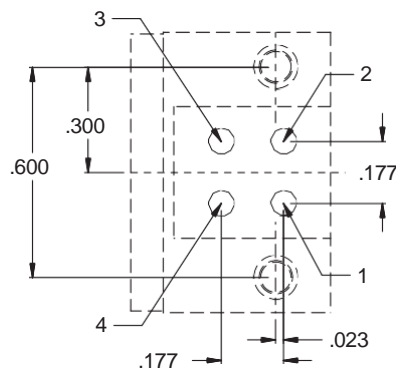

ARRANGEMENT NO. 9-4
(4 #16 CONTACTS)

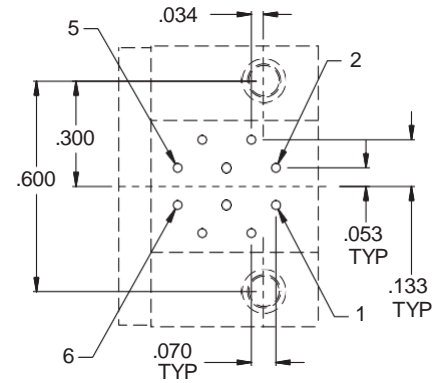

ARRANGEMENT NO. 9-210
(10 #20HD CONTACTS)

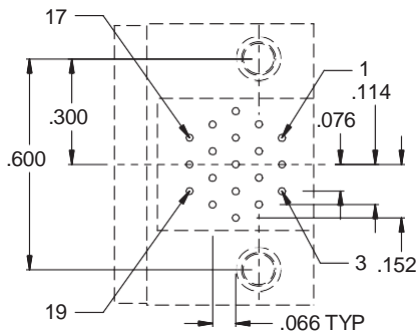

ARRANGEMENT NO. 9-19
(19 #23 CONTACTS)

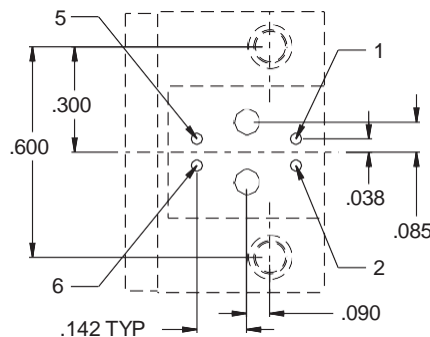

ARRANGEMENT NO. 9-200
(2 #16, 4 #23 CONTACTS)

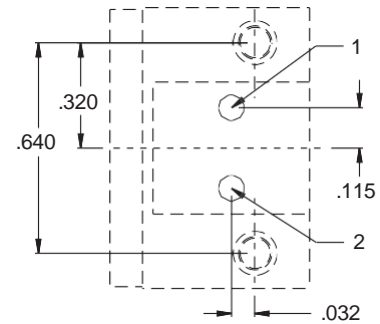

ARRANGEMENT NO. 10-2
(2 #12 CONTACTS)

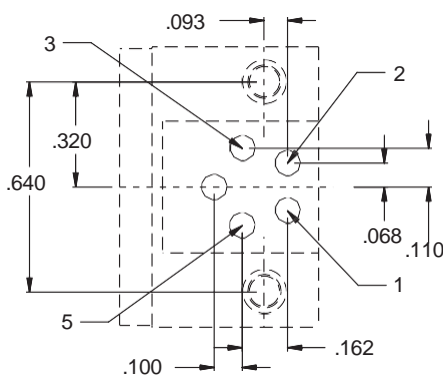

ARRANGEMENT NO. 10-5
(5 #16 CONTACTS)

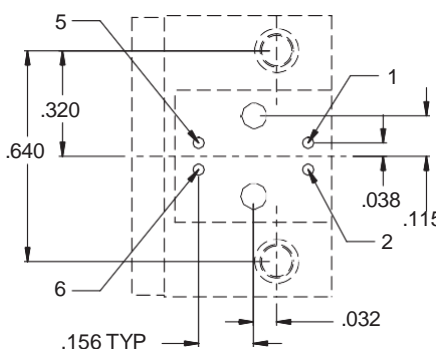

ARRANGEMENT NO. 10-201
(2 #12, 4 #23 CONTACTS)

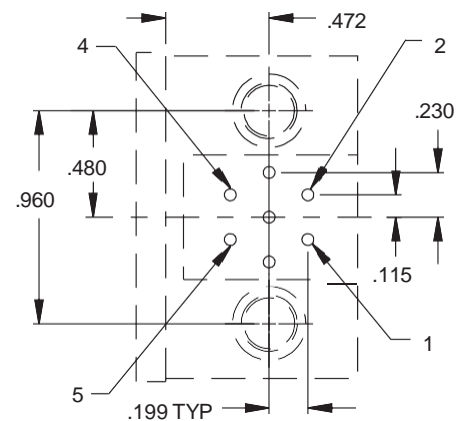

ARRANGEMENT NO. 17-7
(7 #12 CONTACTS)

Dimensions in Inches (millimeters) are subject to change without notice.

