

# Voltage Transducer LV 100-750/SP8

For the electronic measurement of voltages: DC, AC, pulsed..., with galvanic separation between the primary circuit and the secondary circuit.

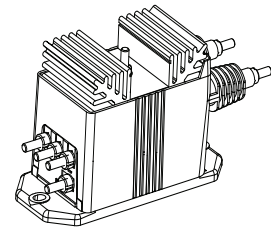

$$U_{PN} = 750 \text{ V}$$



## Features

- Closed loop (compensated) voltage transducer using the Hall effect
- Insulating plastic case recognized according to UL 94-V0
- Primary resistor – incorporated within the housing.

## Special features

- $U_C = \pm 15 (\pm 5 \%) \text{ V}$
- $T_A = -40 \text{ °C} \dots +80 \text{ °C}$
- Shield between primary and secondary
- Connection of primary and secondary circuit on M5 threaded studs.

## Advantages

- Excellent accuracy
- Very good linearity
- Low temperature drift
- Optimized delay time
- Wide frequency bandwidth
- High immunity to external interference.

## Applications

- Single or three phase inverters
- Proplusion and braking choppers
- Proplusion converters
- Auxiliary converters
- Battery chargers.

## Application domain

- Railway (fixed installations and onboard).

## Electrical data

$U_{PN}$	Primary nominal RMS voltage	750	V
$U_{PM}$	Primary voltage, measuring range	0 ... $\pm 1300$	V
$I_{PN}$	Primary nominal RMS current	13.33	mA
$R_M$	Measuring resistance with $\pm 15 \text{ V}$	$R_{M \min}$ $R_{M \max}$ @ $\pm 750 \text{ V}_{\max}$ @ $\pm 1300 \text{ V}_{\max}$	0 210 $\Omega$ 0 100 $\Omega$
$I_{SN}$	Secondary nominal RMS current	50	mA
$S$	Sensitivity	66.67	$\mu\text{A/V}$
$U_C$	Supply voltage ( $\pm 5 \%$ )	$\pm 15$	V
$I_C$	Current consumption	$< 32 + I_S$	mA

## Accuracy - Dynamic performance data

$\epsilon_{\text{tot}}$	Total error @ $U_{PN}, T_A = 25 \text{ °C}$	$\pm 0.9$	%
$\epsilon_L$	Linearity error	$< 0.1$	%
$I_O$	Offset current @ $U_p = 0, T_A = 25 \text{ °C}$	Typ   Max	mA
$I_{OT}$	Temperature variation of $I_O$	-25 °C ... +70 °C   $\pm 0.4$	mA
		-40 °C ... +80 °C   $\pm 0.6$	mA
$t_{D90}$	Delay time to 90 % of the final output value for $U_{PN}$ step	40	$\mu\text{s}$

## General data

$T_A$	Ambient operating temperature	-40 ... +80	$^{\circ}\text{C}$
$T_{A \text{st}}$	Ambient storage temperature	-40 ... +85	$^{\circ}\text{C}$
$N_p/N_s$	Turns ratio	7500 : 2000	
$P_p$	Total primary power loss	10	W
$R_p$	Resistance of primary winding @ $T_A = 25 \text{ °C}$	56.25	k $\Omega$
$R_s$	Resistance of secondary winding @ $T_A = 80 \text{ °C}$	60	$\Omega$
$m$	Mass Standard <sup>1)</sup>	790	g
		EN 50155: 2017	

Note: <sup>1)</sup> Additional information available on request.

**Voltage Transducer LV 100-750/SP8**

Insulation coordination			
$U_d$	RMS voltage for AC insulation test, 50 Hz, 1 min	6 <sup>1)</sup>	kV
		1 <sup>2)</sup>	kV
		Min	
$d_{cp}$	Creepage distance	164.8	mm
$d_{cl}$	Clearance	47.1	mm
$CTI$	Comparative tracking index (group I)	600	

**Notes:** <sup>1)</sup> Between primary and secondary + shield  
<sup>2)</sup> Between secondary and shield.

**Safety**



This transducer must be used in electric/electronic equipment with respect to applicable standards and safety requirements in accordance with the manufacturer's operating instructions.



Caution, risk of electrical shock

When operating the transducer, certain parts of the module can carry hazardous voltage (e.g. primary busbar, power supply). Ignoring this warning can lead to injury and/or cause serious damage.

This transducer is a build-in device, whose conducting parts must be inaccessible after installation. A protective housing or additional shield could be used. Main supply must be able to be disconnected.

## Dimensions LV 100-750/SP8 (in mm)

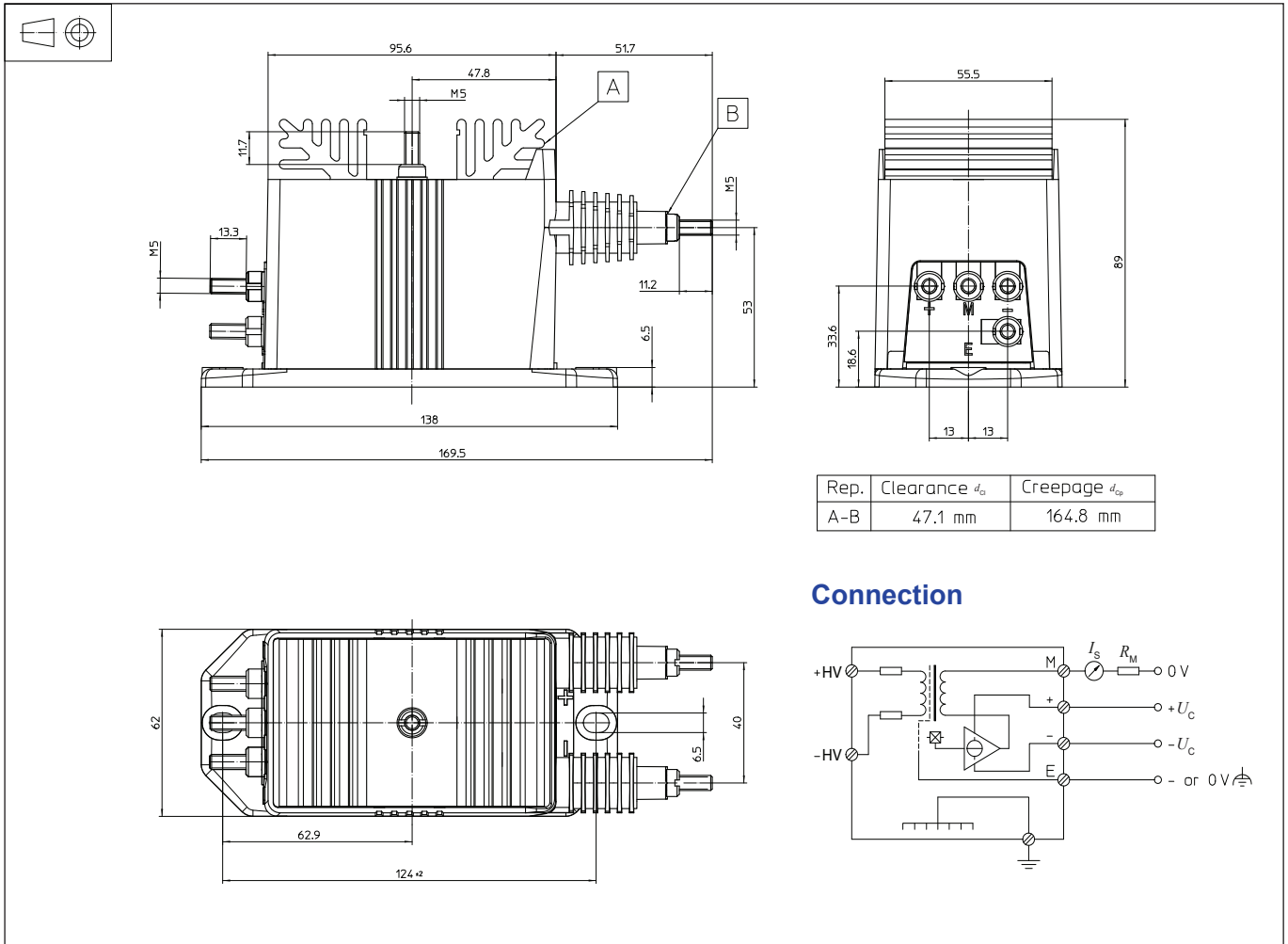

### Connection

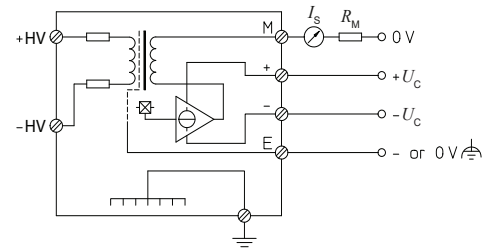

### Mechanical characteristics

- General tolerance  $\pm 0.5$  mm
- Transducer fastening
  - 2 holes  $\varnothing 6.5$  mm
  - 2 M6 steel screws
  - Recommended fastening torque 5 N·m
- Connection of primary
  - M5 threaded studs
  - Recommended fastening torque 2.2 N·m
- Connection of secondary
  - M5 threaded studs
  - Recommended fastening torque 2.2 N·m
- Connection of ground
  - M5 threaded stud
  - Recommended fastening torque 2.2 N·m

### Remarks

- $I_S$  is positive when  $U_p$  is applied on terminal +HV.
- The primary circuit of the transducer must be linked to the connections where the voltage has to be measured.
- Installation of the transducer must be done unless otherwise specified on the datasheet, according to LEM Transducer Generic Mounting Rules. Please refer to LEM document N°ANE120504 available on our Web site: <https://www.lem.com/en/file/3137/download/>.