



益阳市安兴电子有限公司

YIYANG ANXING ELECTRONICS CO., LTD

地址 ADD: 湖南省益阳市龙岭工业园区
主页 Web: <http://www.axboom.com>

电话 TEL: 0737-4688319
传真 FAX: 0737-4688345

规格书

SPECIFICATION

客户 CUSTOMER	
品名 PART NAME	铝电解电容器 Aluminum Electrolytic Capacitors
规格描述 DESCRIPTION	AGL Series(底座型)
安兴料号	
日期 DATE	2024-5-27

核准 APPROVED	审核 CHECKED	拟制 PREPARED
李彦	张光	梁正

客户承认 CUSTOMER APPROVED
承认后请寄回一份 Please return one copy with your approval

1、概述 SCOPE

本承认书规定了 AGL 系列立式铝电解电容器的技术规范。

This specification covers “AGL series” SMD(V-chip) aluminum electrolytic capacitors.

2、参考标准 APPLI CABLE SPECIFICATION

本承认书参考 JIS-C-5141 和 JIS-C-5101 制定。

This approval sheet consulted the institute of JIS-C-5141 and JIS-C-5101.

3、工作温度范围 OPERATING TEMPERATURE RANGE

工作温度范围是电容器在施加额定工作电压条件下，可以长期可靠工作的环境温度范围

-40°C~+105°C

Operating temperature range is the range of ambient temperature at which the capacitor can beoperated continuously at rated voltag

-40°C~+105°C

4、测试环境 ATMOSPHERIC COND I T I O N OF MEASUREMENTS:

如果没有其他规定，标准的测试、检验环境条件如下所示：

环境温度：15 至 35°C

相对湿度：45 至 75%

大气压力：86kpa 至 106kpa

如果对测试结果有异议，可以在以下条件测试：

环境温度：25±2°C

相对湿度：60 至 70%

大气压力：86kpa 至 106kpa

Unless otherwise specified, the standard range of atmospheric conditions for making Measurements and tests are as follows

Ambient temperature : 15 to 35°C

Relative humidity : 45 to 75%

Air pressure: 86kpa to 106kpa

If there may be doubt on the results, measurements shall be made within the following limits

Ambient temperature : 25 ±2°C

Relative humidity : 60 to 70%

Air pressure: 86kpa to 106kpa

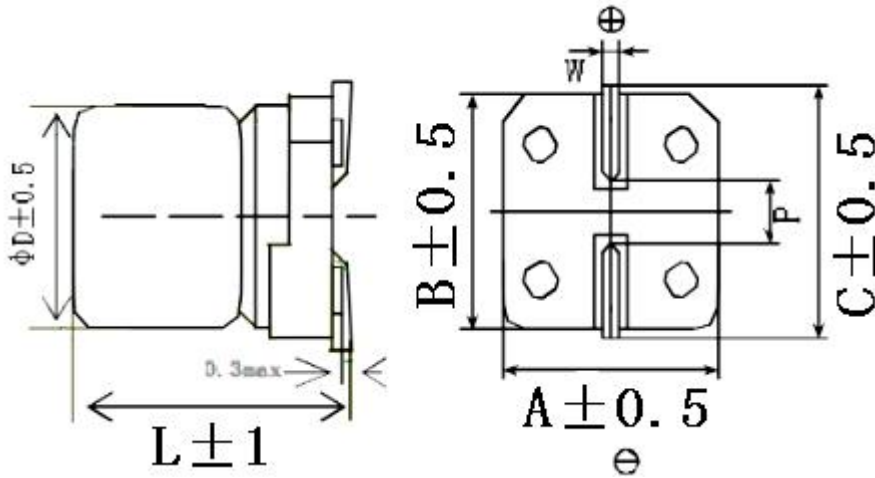
5、主要技术参数 Specifications
5.1 外形图及尺寸表 Case size table(单位:mm)

尺寸 Size code	D	L	A	B	C	W	P±0.3
6.3×10.5	6.3	10.5	6.6	6.6	7.2	0.5~0.8	1.9
8×10.5	8	10.5	8.3	8.3	9.0	0.7~1.1	3.1
8×12.5	8	12.5	8.3	8.3	9.0	0.7~1.1	3.1
10×13.5	10	13.5	10.3	10.3	11.0	0.7~1.1	4.5

5.2 技术参数 Technical parameter

序号 NO	系列 Series	工作电压 Voltage (V)	容量 Capacitance (μF)	尺寸 size (mm)	容量偏差 Tolerance	损耗 Tanδ @120Hz	漏电流 Lc (μA) 2min	额定纹波电流 Ripple current (mA rms) @105°C 100kHz	寿命 Life (hours) 105°C
1	AGL	400	2.2	6.3*10.5	±20%	≤0.15	≤135.2	63	2000H
2	AGL	400	3.3	6.3*10.5	±20%	≤0.15	≤152.8	72	2000H

5.3 频率补偿系数 Frequency correction factor for ripple current

频率 (Hz) Frequency	120	1K	10K	100K
额定电压 (V. DC) Rated Voltage				
160V~450V	0.5	0.8	0.9	1.00

6、可靠性试验 Reliability Test

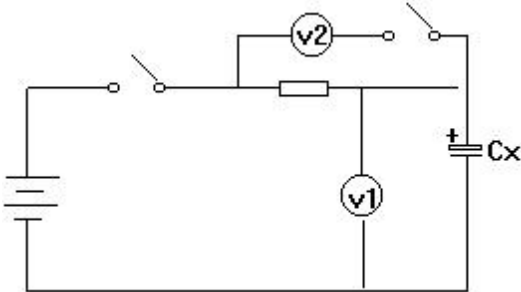
序号 NO	项目 Item	条 件 Conditions	规 格 Specifications
6.1	电容量 Capacitance	测试频率:120HZ±20% 测试电路:串联等效 测试电压:0.5Vrms 以下 Measuring frequency : 120HZ±20% Measuring circuit: Series equivalent circuit Measuring voltage: 0.5Vrms or less +1.5 to 2.0 VDC	静电容量允许偏差 -20~+20% Capacitance Tolerance -20~+20%
6.2	损耗角正切值 Dissipation Factor	测试条件与 6.1 电容量测试相同 Testing condition are the same as 6.1 for capacitance	Refer to table 1.
6.3	漏电流 Leakage current	电容器接 1000±10Ω 的保护电阻施加电压 2 分钟后的测试电流。 The rated voltage shall be applied across the capacitor and its protective resistor which shall be 1000±10Ω. The leakage Current shall then be measured after an electrocution period of 2 min. The leakage current shall be calculated by the following equation. 漏电流: $(I) = E/R_s$ Leakage current: E: 直流电压表的电压值 Voltage measured with DC voltmeter R _s : 标准电阻的电阻值 Resistance of the protective resistor 测定电路 measurement circuit 	$I_c \leq 0.04CV + 100(\mu A)$ I _c : 漏电流(μA) C: 容量(μF) V: 额定工作电压(V) $I_c \leq 0.04CV + 100(\mu A)$ I _c : Leakage current(μA) C: Capacitance (μF) V: Rated voltage(V)

电压将下法 voltage drop method)
 R_s:标准电阻的电阻值 (1000±10Ω)
 protective resistor
 直流电压表或电子电压表
 DC voltmeter or electronic voltmeter
 S1:开关 switch
 S2:电压表保护用变换开关
 Protective switch for a voltmeter
 CX:待测电容器 test capacitance

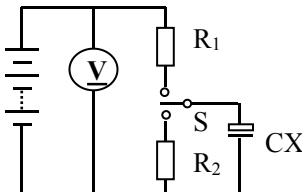
序号 NO	项 目 Items	条 件 Conditions	规 格 Specifications
6.4	浪涌电压 Surge Voltage	<p>在下面规定的温度下,通过指定的浪涌电压(Page 6,table 1), 6.0 分钟(充电 30 秒,放电 5 分 30 秒)为一周,往返 1000 回合,常温常湿下放置 1-2 小时达到热平衡状态测定满足</p> <p>The capacitor shall be subjected to 1000 cycles at a temperature specified below, each consisting of a charge period of 30±5s, followed by a discharge period of approx 5min.30 s. And the capacitor shall be stored 1-2 hours under standard atmospheric conditions to obtain thermal stability , after which measurement shall be made</p> <p>应加电压: 见表 1 Test voltage: See Table 1 温度:15~30℃ Test Temperature : 15~30℃ 测试回路 Measurement circuit</p>  <p>R1: 串联保护电阻 (1KΩ) Protective series resistor (1KΩ) V: 直流电压表 DC Voltage R2: 放电电阻 Discharge resister (1KΩ) S: 切换开关 Switch Cx: 待测电容器 Test Capacitor</p>	漏电流: 不超过规定值 Leakage Current: Not more than the specified value 容量变化: 初始值的±15%以内 Capacitance change: Within ±15% of the initial value 损耗角正切: 不超过规定值 Dissipation Factor : Not more than the specified value
6.5	防爆试验 Safety vent Test	<p>电容器上应加 1A 逆向直流电,防爆壳正常动作,无金属片飞散、起火、爆炸。</p> <p>The capacitor is shall be connected in inverse polarity, and applied DC current at 1A constant, The pressure relief device shall open in such a way as to avoid any danger of fire or explosion of capacitor elements (Terminal and mental foil etc.) or cover</p>	/

序号 NO.	项目 Items	条 件 Conditions																										
6.6	温度特性 Temperature Characteristic	<p>电容器根据下表的次序处理。 The capacitor shall be subjected in turn to the procedures specified below.</p> <table border="1"> <thead> <tr> <th>阶段</th> <th>温度</th> <th>时间</th> </tr> </thead> <tbody> <tr> <td>1</td> <td>20±2℃</td> <td>热平衡状态</td> </tr> <tr> <td>2</td> <td>-25℃</td> <td>2h</td> </tr> <tr> <td>3</td> <td>20±2℃</td> <td>热平衡状态</td> </tr> <tr> <td>4</td> <td>105℃</td> <td>2h</td> </tr> <tr> <td>5</td> <td>20±2℃</td> <td>热平衡状态</td> </tr> </tbody> </table> <p>电容器放置在每一温度下，待阻抗或电容量稳定后方可测试。 * The capacitor should be stored at each temperature until measured impedance or capacitance are stabilized .</p> <table border="1"> <tbody> <tr> <td rowspan="2">阶段 2 Step 2</td> <td>阻抗比（对阶段 1） Impedance ratio</td> <td>见表 1 (Page 6) refer to table 1</td> </tr> <tr> <td>静电容量变化率（对阶段 1） Change in capacitance</td> <td>within -20~+20% of step 1</td> </tr> <tr> <td>阶段 4 Step 4</td> <td>静电容量变化率（对阶段 1） Change in capacitance</td> <td>within -20~+20% of step 1</td> </tr> </tbody> </table> <p>阶段 1：测定容量，损耗和阻抗值。 Step 1: Capacitance, Dissipation Factor and impedance shall be measured. 阶段 2：放置 2 小时后，达到热平衡状态再测。 Step 2: After the capacitor being stored for 2 hours, Capacitance, Dissipation Factor and impedance shall be Measured. The measurement shall be made at thermal stability. 阶段 4：放置 2 小时后，达到热平衡状态再测。 Step 4: After the capacitor being stored for 2 hours, Capacitance, Dissipation Factor and impedance shall be Measured. The measurement shall be made at thermal stability.</p>	阶段	温度	时间	1	20±2℃	热平衡状态	2	-25℃	2h	3	20±2℃	热平衡状态	4	105℃	2h	5	20±2℃	热平衡状态	阶段 2 Step 2	阻抗比（对阶段 1） Impedance ratio	见表 1 (Page 6) refer to table 1	静电容量变化率（对阶段 1） Change in capacitance	within -20~+20% of step 1	阶段 4 Step 4	静电容量变化率（对阶段 1） Change in capacitance	within -20~+20% of step 1
阶段	温度	时间																										
1	20±2℃	热平衡状态																										
2	-25℃	2h																										
3	20±2℃	热平衡状态																										
4	105℃	2h																										
5	20±2℃	热平衡状态																										
阶段 2 Step 2	阻抗比（对阶段 1） Impedance ratio	见表 1 (Page 6) refer to table 1																										
	静电容量变化率（对阶段 1） Change in capacitance	within -20~+20% of step 1																										
阶段 4 Step 4	静电容量变化率（对阶段 1） Change in capacitance	within -20~+20% of step 1																										

序号 No.	项目 Items	条 件 Conditions	规 格 Specifications
6.7	高温负荷 Load life	<p>在 105±2℃ 的恒温箱内，电容器施加最大允许纹波电流，施加直流电压和交流电压的峰值的和要等于额定电压，时间 2000 小时，试验结束后，在标准状态下放置 16 小时后进行测试。</p> <p>The capacitor shall be placed in a circulating air oven at an ambient temperature of 105±2℃。 It must not be subjected to direct radiation from heating elements. DC voltage and the rated ripple current shown in table shall be applied for a period of 2000 hours. The sum of the DC voltage and peak AC voltage must not exceed the full rated voltage of the capacitor. It shall be subjected to standard atmospheric for 16 hours, after which measurement shall be made.</p>	<p>漏电流：不超过规定值 容量变化：初测值的±30 % 以内 损耗角正切：不超过规定值的 3 倍</p> <p>Leakage current : Not more than Initial specified value Capacitance change : Within ±30 % of initial value Dissipation factor : Not more than 300% of initial specified value</p>
6.8	高温存储 Shelf life	<p>在 105±2℃ 环境下无负荷贮存 1000 h，至少恢复 16 小时后。</p> <p>The capacitors are then stored with no voltage at a temperature of 105±2℃ for 1000 h and then resumed 16 hours.</p>	<p>漏电流：不超过规定值的 2 倍 容量变化：初测值的±20 % 以内 损耗角正切：不超过规定值的 2 倍</p> <p>Leakage current : Not more than 200% of initial specified value Capacitance change : Within ±20 % of initial value Dissipation factor : Not more than 200% of initial specified value</p>

※ 表 1 Table 1

额定工作电压 Rated voltage(V)	浪涌电压 Surge voltage(V)	损耗角正切值 Dissipation factor	阻抗比 Impedances ratio
			$Z_{-25^{\circ}\text{C}}/Z_{20^{\circ}\text{C}}$
160	200	0.15	3
200	250	0.15	3
250	300	0.15	3
400	450	0.15	6
450	500	0.16	6

序号 NO	项目 Item	条 件 Conditions	规 格 Specifications																				
6.9	可焊性 Solder ability	浸渍时间 Solder press time: 2.5±0.5s 焊接温度 Solder temperature: 255+5/-0℃	浸渍面积 90%以上附着 At least 90% of Circumferential surface of the dipped portion of termination shall be covered with new solder																				
6.10	端子强度 terminal Strength	端子抗拉强度: 沿电容器端子引线方向施加固定重力*1N 10 秒钟. <table border="1" data-bbox="434 745 1088 831"> <tr> <td>引线直径Φ</td> <td>0.5</td> <td>0.6</td> <td>0.8</td> <td>1.0</td> </tr> <tr> <td>拉力 N</td> <td>5.0</td> <td>10</td> <td>20</td> <td></td> </tr> </table> 端子抗弯强度: 在电容器引线施加固定重力*2N,然后,将电容体弯折 90°后回到原位。 上述过程在 5 秒内完成。 <table border="1" data-bbox="434 999 1088 1084"> <tr> <td>引线直径Φ</td> <td>0.5</td> <td>0.6</td> <td>0.8</td> <td>1.0</td> </tr> <tr> <td>拉力 N</td> <td>5.0</td> <td>10</td> <td>20</td> <td></td> </tr> </table> Tensile strength of termination: A static load of* IN shall be applied to the terminal in the axial direction and acting in a direction away from the body for 10 sec. Bending strength of termination: Hang the specified dead weight of*2N,then bent the body through 90°with The same speed ,again return to the original position Carry out this operation in 5 sec.	引线直径Φ	0.5	0.6	0.8	1.0	拉力 N	5.0	10	20		引线直径Φ	0.5	0.6	0.8	1.0	拉力 N	5.0	10	20		测量静电容量时,应无接触不良、开路或短路以及无可见机械损伤 When the capacitance is measured, there shall be no intermittent contacts or open –or short –circuiting . There shall be no such mechanical damage as terminal damage etc.
引线直径Φ	0.5	0.6	0.8	1.0																			
拉力 N	5.0	10	20																				
引线直径Φ	0.5	0.6	0.8	1.0																			
拉力 N	5.0	10	20																				
6.11	振动试验 Resistance to Vibration	依据 IEC60068-2-6 试验。 在 3 个互相垂直的方向分别施加 2 小时振动, 共 6 小时 To comply with IEC60068-2-6 Direction and duration of vibration: 3 orthogonal directions mutually each for 2h,Total 6h.	测量静电容量时,应无接触不良、开路或短路以及无可见机械损伤 When the capacitance is measured, there shall be no intermittent contacts or open –or short –circuiting . There shall be no such mechanical damage as terminal damage etc.																				

序号 NO	项目 Item	试验方法 Experiment method	特性 Performance
6.12	耐焊接热 Resistance to soldering heat	温度:270+2/-0℃ Test Temperature: 270±5℃ 时间:10±0.5 s Test time: 10±0.5s	容量变化:在初始值±10%范围内 损耗角正切值: 不超过规定值 漏电流: 不超过规定值 外观:无异状 Variation of capacitance: Within ±10% of the initial value Dissipation factor: Not more than the specified value. Leakage current: Not more than the specified value. Appearance: No remarkable abnormality.
6.13	稳态湿热 Resistance to damp heat (steady state)	依据 IEC60068-2-3 进行试验 试验温度: 40±2℃ 试验时间: 240±8h 相对湿度: 90~95% 试验后, 电容器在标准大气条件下 1~2 小时, 然后测试 参数 To comply with IEC60068-2-3 Test temperature: 40±2℃ Test time : 240±8h Relative humidity: 90~95% After completion of test, the capacitor shall be subjected to standard atmospheric conditions for 1 to 2 hours, after which measurements shall be made.	容量变化: 在初始值±15%范围 内。 损耗角正切值: 不超过规定值。 漏电流: 不超过规定值 外观:无异状 Variation of capacitance: Within ±15% of the value before test. Dissipation factor: Not more than the specified value Leakage Current: Not more than the specified value Appearance: No remarkable abnormality.

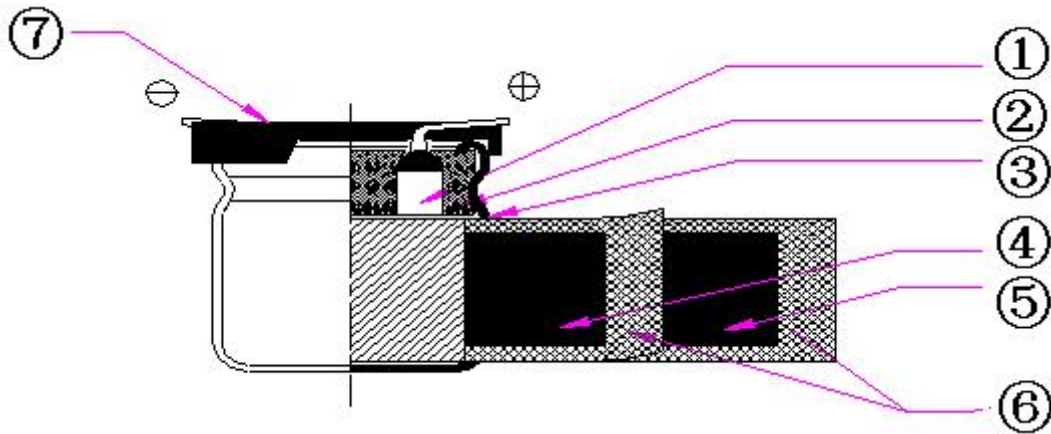
7、内部结构及材料表 Frame and material
7.1 构造图 Component Structure

7.2 材料表 Material Table

序号 No.	部件名称 Parts	材料名称 Material	主要供应厂家名称 Main supply Factory
1	引出线	铝线+镀锡铜钢线	大塘电子 益利达
2	橡胶塞	丁基橡胶 IIR rubber	浙江天华电子 成合电子
3	铝壳 CASE	99.5%纯度铝（内防爆）	联亿电子 奥星
4	阳极箔 AL - foil(+)	99.98%形成铝箔	旭阳电子
5	阴极箔 AL - foil(-)	化成铝箔	上高飞乐 鸿坤
6	电解纸 Separstor paper	电解电容器纸	山东鲁南 创元
7	座板 BASE	PPS	浙江天台天三

8、标识 Marking

A) 电容器标识内容如下:

Capacitors shall be legibly marked with the following:

1) 产品系列

Manufacture' s mark

2) 额定电压和额定电容

Rated voltage and nominal capacitance

3) 负极标识

Negative polarity

B) 图样

Drawing (for 4 ~ 10)(单位: mm)

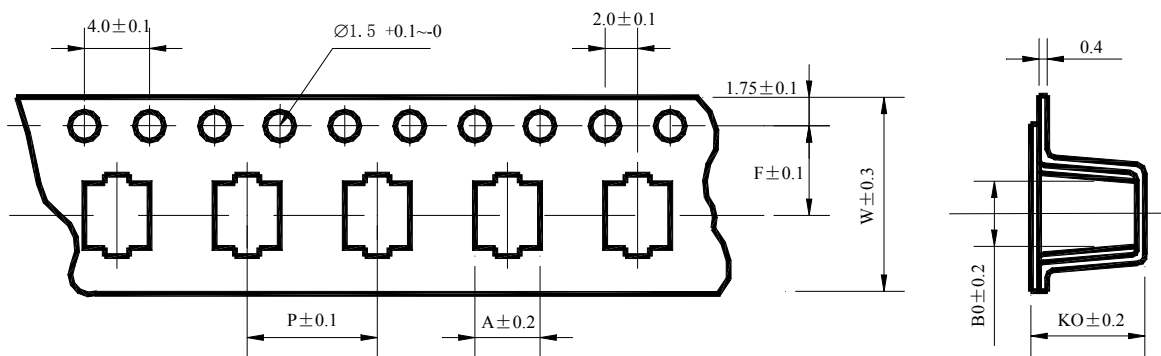

$\varnothing D \times L$	6.3×10.5	8×10.5	8×12.5	10×13.5
W	16.0	24.0	24.0	24.0
P	12.0	16.0	16.0	16
F	7.5	11.5	11.5	11.5
A	7.0	8.7	8.7	10.7
B0	7.0	8.7	8.7	10.7
KO	11.0	11.0	13.3	14.5

C) 编带包装盘 Reel (单位: mm)

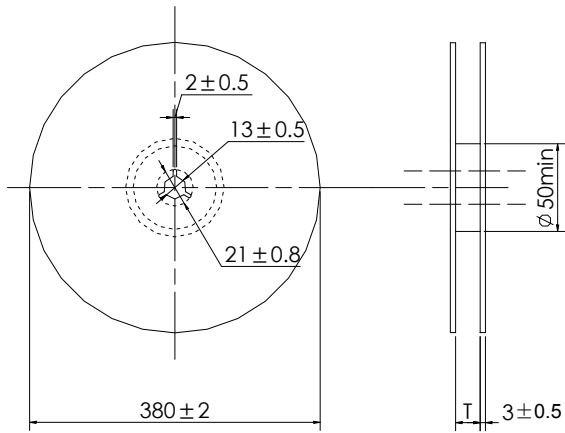

ϕD	6.3	8	10
T	18 ± 0.5	26 ± 0.5	26 ± 0.5

D) 包装数量 Package quantity

尺寸 $\Phi D \times L$	数量/每盘 Quantity/Reel	盘数/大包装箱 pcs/Large packing box
6.3 × 10.5	750pcs	16 盘/12000pcs
8 × 10.5	500pcs	12 盘/6000pcs
8 × 12.5	400pcs	12 盘/4800pcs
10 × 13.5	400pcs	12 盘/4800pcs
10 × 16.5	350pcs	12 盘/4200pcs

9、回流焊建议 Reflow Soldering Recommendation

- 电容器表面温度在 $T^{\circ}\text{C}$ 以下。

Temperature at surface of capacitor shall not exceed $T^{\circ}\text{C}$.

- 电容器表面温度在 200°C 以上和 T_1 温度的持续时间不应超过 t 和 t_1 秒。

The duration for over 200°C temperature and $T_1^{\circ}\text{C}$ at surface of capacitor shall not exceed t and t_1 seconds, respectively.

- 预热温度控制在 100°C 至 200°C 之间，预热时间控制在180秒内。

Preheat shall be done at 100°C to 200°C and for Maximum 180 seconds.

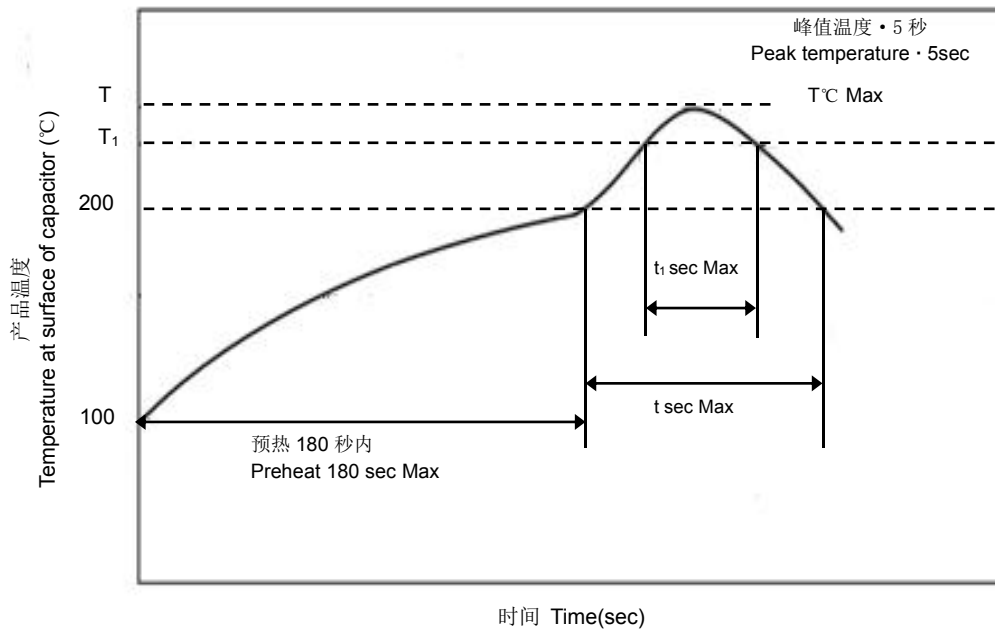

尺寸 Case size (mm)	$T(^{\circ}\text{C})$ ①	$T_1(^{\circ}\text{C})$	$t(\text{sec})$ ②	$t_1(\text{sec})$ ③	回流焊次数 Reflow cycle
Ø6.3	250	230	90	40	1
Ø8	240	230	90	30	1
Ø10	235	230	60	30	1

① 峰值温度/Peak temperature

② 温度 200°C 以上最大时间/The duration over 200°C (Max)

③ 温度 T_1 以上持续时间/The duration over $T_1^{\circ}\text{C}$

- 如果电容器受除回流焊允许范围以外的条件影响，请与我们联系。

Please contact us if capacitors are subject to the conditions other than the allowable range of reflow.

10、其它说明

10.1 铝电解电容器使用注意事项 Important information on the application of aluminum electrolytic capacitors

(1) 直流铝电解电容器应按正确的极性使用 DC electrolytic capacitors are polarized

当直流铝电解电容器按反极性接入电路时，电容器会导致电子线路短路，由此产生的电流会引致电容器损坏。若电路中有可能在负引线施加正极电压，请选无极性产品。

When reverse voltage is applied on DC electrolytic capacitor, the capacitor will become short circuited please use non polarized capacitors in the circuit are damage due to abnormal current flows through the capacitors since the circuit where the positive voltage may be applied to the cathode terminal.

(2) 在额定工作电压以下使用 Use capacitor within rated voltage

当电容器上所施加电压高于额定工作电压时，电容器的漏电流将上升，其电气特性将在短时期内劣化直至损坏。请注意电压峰值勿超出额定工作电压。

When capacitor is used at higher voltage than the rated voltage, leakage current increases, characteristics drastically deteriorate and damage in a short period may occur as a result .please take extra caution that the peak voltage should not exceed the rated voltage.

(3) 作快速充放电使用 Charge and discharge application

当常规电容器被用作快速充电用途。其使用寿命可能会因为容量下降，温度急剧上升等而缩减。

When aluminum electrolytic capacitors for general purpose are employed in rapid charge and discharge application, its life expectancy may be shortened by capacitance decrease, heat rise, etc.

(4) 电容器贮存 Store the capacitor

当铝电解电容器作了长期贮存后,其漏电流通常升高.贮存温度愈高,漏电流上升愈快.因此应注意贮存环境的选择,在电容器上施加电压后,漏电流值将不断下降,在铝电解电容器的漏电流值上升对电路有不良影响的,请在使用前充电处理.

I creased leakage current is common in aluminum capacitors which have been stored for long period of time .The higher the storage temperature, the higher the leakage current increase therefore please take precautions concerning the storage location. The leakage current causes problems in the circuit, apply voltage (aging) before using.

(5) 施加纹波电流应小于额定值 Ripple current applied to capacitor should not exceed the rated value.

施加纹波电流超过额定值后,会导致电容器体过热,容量下降,寿命缩短.所施加纹波电压的峰值应小于额定工作电压.

Excessive heat will reduce capacitance and result in shortened life of capacitor if ripple currents exceeding the specified rated value are applied .the peak value of the ripple voltage should be less than the rated voltage.

(6) 引出线强度 Lead stress

当拉力施加到电容器引出线，该拉力将作用于电容器内部，这将导致电容器内部短路、开路或漏电流上升。在电容器焊装到电路板，请勿强烈摇动电容器。

When a strong force is applied to the lead wires or terminals. Stress is put on the internal connections. This may result in short circuit, open circuit or increased leakage current. It is not advisable to bend or handle a capacitor after it has been soldered to the PC board.

(7) 焊接过程耐热性 Heat resistance at the soldering process

铝电解电容器装至电路板进行浸焊或波焊时，其塑料套管可能因焊接时间过长、温度过高而发生破裂或二次收缩。

In the dip soldering process of PC board with aluminum electrolytic capacitors mounted, secondary shrinkage or crack of PVC sleeve may be observed when solder temperature is too high or dipping time is too long.

(8) 电路板的安装孔孔距及安装位置 Hole pitch and position of PC board.

电路板的安装孔的设计应与产品说明书的引线脚距相一致，如果将电容器强行插入孔距不配套的电路板，那么会有应力作用于引出线，这将导致短路或漏电流上升。

A PC board must be designed so its hole pitch coincides with the lead pitch(lead spacing) of the capacitor specified by the catalog or specifications. When a capacitor is forcibly inserted into an unmatched hole pitch, a stress is put on the leads. This could result in a short circuit or increased leakage current.

10.2 本产品无铅、无污染 This product is lead free and environmental friendly

本产品（包括所有构件）完全符合欧盟 RoHS 要求，即 6 种有害物质的最大含量均不超过如下要求：

This product is according to the standard of RoHS, it means the max capacitance of six harmful material not over the following request:

Cd (镉) -100PPM

PB (铅) -1000PPM

Hg (汞) -1000PPM

Cr⁶⁺ (六价铬) -1000PPM

PBBS (多溴联苯) -1000PPM

PBDEs (多溴联苯醚) -1000PPM