

Product Specification

Number: L-KLS10-CD81

Name: Aluminum Electrolytic Capacitors

Specification: _____

Customer: _____

Date: 2024-05-11

Customer Signature:



WWW.KLSELE.COM

NINGBO KLS ELECTRONIC CO; LTD

Tel : 0086-574-86828566

Fax : 0086-574-86824882

ADD : NO. 8-1, RONGXIA RD. XIAPU SHANQIAN
INDUSTRIAL ZONE BEILUN NINGBO ZHEJIANG.

| Compile | Check | Review | Approval |
|---------|--------|--------|----------|
| Jenny | Jack.C | | |

二、适用范围 Adapt Range

本产品规格书适用于宁波开乐亿启电子有限公司的CD81 铝电解电容器产品，本技术规范条文解释权归本公司所有。

The products specification is adapted to series CD81 Aluminum Electrolytic Capacitors of Ningbo kls electronic co.,ltd. reserves the right of final interpretation for this technical specification.

三、参考标准 APPLICABLE SPECIFICATION

本规格书参考 JIS-C-5101-1 和 JIS-C-5101-4 制定。

This specification sheet consulted the institute of JIS-C-5101-1 and JIS-C-5101-4.

四、外形图及尺寸表 Case Size Table

↵

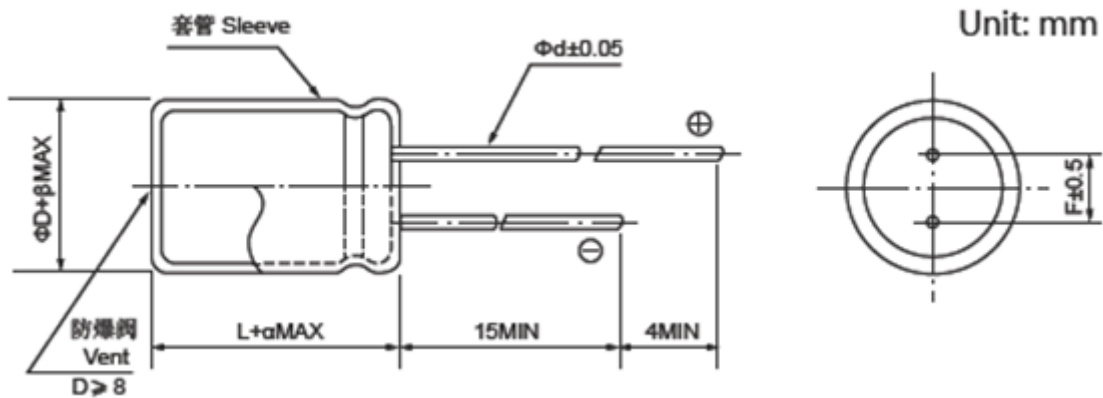

| | | | | | | | | | |
|----------|-----|-------|-------------|----------|-----|---------|-----|-----|-------------|
| ΦD | 5 | 6/6.3 | 8 | | 10 | 12.5/13 | 16 | 18 | ≥ 22 |
| F | 2.0 | 2.5 | 3.5 | | 5.0 | 5.0 | 7.5 | 7.5 | 10 |
| Φd | 0.5 | | $L \leq 14$ | $L > 14$ | 0.6 | | 0.8 | | 0.8/1.0/1.5 |
| | | | 0.5 | 0.6 | | | | | |

| | |
|----------|-----|
| α | 0.5 |
|----------|-----|

| | |
|---------|-----|
| β | 0.5 |
|---------|-----|

五、技术性能 Specifications

| 项目 Item | 特性 Performance Characteristics | | | | | | | | | | | | | | | | | | | | | | | | | | | | | | | | |
|---|---|------------------|------|------|------|------|------|------|------|-----|-----|-----------------|------|------|------|------|------|------|------|------|------|---|-----------------|--|--|--|--|--|--|--|--|---|---|
| 测试环境 Condition of test | <p>如果没有其他规定，标准的测试、检验环境条件如下所示： 环境温度：15℃~35℃ 相对湿度：45%~75% 大气压力：86kpa~106kpa</p> <p>如果对测试结果有异议，可以在以下条件下测试： 环境温度：20±1℃ 相对湿度：60%~67% 大气压力：86kpa~106kpa</p> <p>Unless otherwise specified, the standard range of atmospheric conditions for making measurements and tests are as follows Ambient temperature : 15℃ to 35℃ Relative humidity : 45% to 75% Air pressure : 86kpa to 106kpa</p> <p>If there may be doubt on the results, measurements shall be made within the following limits Ambient temperature : 20±1℃ Relative humidity : 60% to 67% Air pressure : 86kpa to 106kpa</p> | | | | | | | | | | | | | | | | | | | | | | | | | | | | | | | | |
| 使用温度范围 Operating temperature range | -55° ~+105℃ | | | | | | | | | | | | | | | | | | | | | | | | | | | | | | | | |
| 额定电压范围 Rated voltage range | 10~120V.DC | | | | | | | | | | | | | | | | | | | | | | | | | | | | | | | | |
| 标称电容量允许偏差 Capacitance tolerance | ±20%(+20℃,120Hz) | | | | | | | | | | | | | | | | | | | | | | | | | | | | | | | | |
| 漏电流 Leakage current | <p>$I \leq 0.01CV$ 或者 $3\mu A$ 中任意一个较大值 $1 \leq 0.01CV$ or $3\mu A$, Whichever is greater I :漏电流(μA), C:静电容量(μF) V:额定电压(V) (20℃,2 分钟) Where, I: Max . leakage current(μA), C: Nominal capacitance(μF), V : Rated voltage(V) (at 20℃, after 2 minutes)</p> | | | | | | | | | | | | | | | | | | | | | | | | | | | | | | | | |
| 损耗角正切值 (tg δ) Dissipation factor (+20℃,120Hz) | <table border="1" data-bbox="411 1451 1318 1541"> <tr> <td>Rated Voltage(v)</td> <td>10</td> <td>16</td> <td>25</td> <td>35</td> <td>50</td> <td>63</td> <td>80</td> <td>100</td> <td>120</td> </tr> <tr> <td>tg δ (Max)</td> <td>0.19</td> <td>0.16</td> <td>0.14</td> <td>0.12</td> <td>0.10</td> <td>0.09</td> <td>0.09</td> <td>0.08</td> <td>0.12</td> </tr> </table> <p>When rated capacitance is over 1000 μ F, tg δ shall be added 0.02 to the listed value with increase of every 1000 μ F.</p> | Rated Voltage(v) | 10 | 16 | 25 | 35 | 50 | 63 | 80 | 100 | 120 | tg δ (Max) | 0.19 | 0.16 | 0.14 | 0.12 | 0.10 | 0.09 | 0.09 | 0.08 | 0.12 | | | | | | | | | | | | |
| Rated Voltage(v) | 10 | 16 | 25 | 35 | 50 | 63 | 80 | 100 | 120 | | | | | | | | | | | | | | | | | | | | | | | | |
| tg δ (Max) | 0.19 | 0.16 | 0.14 | 0.12 | 0.10 | 0.09 | 0.09 | 0.08 | 0.12 | | | | | | | | | | | | | | | | | | | | | | | | |
| 温度特性 Temperature characteristics (impedance ratio at 120Hz) | <table border="1" data-bbox="411 1657 1353 1803"> <tr> <td>额定电压 Ur(v)</td> <td>10</td> <td>16</td> <td>25</td> <td>35</td> <td>50</td> <td>63</td> <td>80</td> <td>100</td> <td>120</td> </tr> <tr> <td>Z(-25℃)/Z(+20℃)</td> <td colspan="8"></td> <td>2</td> <td>3</td> </tr> <tr> <td>Z(-40℃)/Z(+20℃)</td> <td colspan="8"></td> <td>3</td> <td>6</td> </tr> </table> | 额定电压 Ur(v) | 10 | 16 | 25 | 35 | 50 | 63 | 80 | 100 | 120 | Z(-25℃)/Z(+20℃) | | | | | | | | | 2 | 3 | Z(-40℃)/Z(+20℃) | | | | | | | | | 3 | 6 |
| 额定电压 Ur(v) | 10 | 16 | 25 | 35 | 50 | 63 | 80 | 100 | 120 | | | | | | | | | | | | | | | | | | | | | | | | |
| Z(-25℃)/Z(+20℃) | | | | | | | | | 2 | 3 | | | | | | | | | | | | | | | | | | | | | | | |
| Z(-40℃)/Z(+20℃) | | | | | | | | | 3 | 6 | | | | | | | | | | | | | | | | | | | | | | | |

| | <table border="1" style="width: 100%; border-collapse: collapse;"> <tr> <th style="width: 20%;">阶段</th> <th style="width: 30%;">温度</th> <th style="width: 30%;">时间</th> </tr> <tr> <td>1</td> <td>20±2℃</td> <td>--</td> </tr> <tr> <td>2</td> <td>-25, -55⁺⁰₋₃℃</td> <td>2h</td> </tr> <tr> <td>3</td> <td>20±2℃</td> <td>15min</td> </tr> <tr> <td>4</td> <td>105⁺³₀℃</td> <td>2h</td> </tr> </table> <p>阶段 1: 测量容量和阻抗 (Z 20℃ 120Hz±20%) 阶段 2: 电容器恒温贮存 2 小时, 在热平衡状态测阻抗(Z -25, -40℃ 120Hz±20%) 阶段 3: 恢复到 20±2℃, 保持 15 分钟 阶段 4: 电容器恒温贮存 2 小时, 在热平衡状态测电容量 Step 1: Capacitance and impedance shall be measured. (Z 20℃ 120Hz±20%) Step 2: After the capacitor being stored for 2 hours, impedance shall be measured at thermal stability. (Z -25, -40℃ 120Hz±20%) Step 3: To restore to 20 + 2 °C, keep for 15 minutes Step 4: After the capacitor being stored for 105℃ 2 hours, capacitance shall be measured .The measurement shall be made at thermal stability</p> | 阶段 | 温度 | 时间 | 1 | 20±2℃ | -- | 2 | -25, -55 ⁺⁰ ₋₃ ℃ | 2h | 3 | 20±2℃ | 15min | 4 | 105 ⁺³ ₀ ℃ | 2h | <p>阶段 2: 阻抗值与阶段 1 阻抗值相比, 不大于上表要求。 阶段 4: 容量变化应在初始值的±20% 范围内 Step 2: Impedance value ratio to the value at step 1 shall be not more than the value given on the table Step 4: Variation of capacitance Within ±20% of the initial value.</p> |
|-------------------------------|--|-------------------------------|--|---------------------------|--|----------------------|--|---------|--|------------------------|------------------------------------|----------|-------|----------|----------------------------------|----|---|
| 阶段 | 温度 | 时间 | | | | | | | | | | | | | | | |
| 1 | 20±2℃ | -- | | | | | | | | | | | | | | | |
| 2 | -25, -55 ⁺⁰ ₋₃ ℃ | 2h | | | | | | | | | | | | | | | |
| 3 | 20±2℃ | 15min | | | | | | | | | | | | | | | |
| 4 | 105 ⁺³ ₀ ℃ | 2h | | | | | | | | | | | | | | | |
| <p>耐久性 Load life</p> | <p>在 105℃环境中,连续加载额定直流电压与额定纹波电流(所加电压峰值不超过额定工作电压)规定时间后,待温度恢复到 20℃进行测量时, 应满足以下要求。The following specification shall be satisfied when the capacitors are restored to 20℃ after subjected to DC voltage with the rated ripple current is applied for the specified period of time at 105℃</p> <table border="1" style="width: 100%; border-collapse: collapse;"> <tr> <td style="width: 30%;">静电容量变化率 Capacitance change</td> <td style="width: 30%;">≤初始值的±25% (10V: ≤±30%) ± 25% of the initial value (10V: ≤±30%)</td> <td style="width: 10%;">直径 dia</td> <td style="width: 30%;">寿命 (小时) Load Life (hours) 10~120V</td> </tr> <tr> <td>损失角正切值 D.F. tan δ</td> <td>≤初始规格值的 200% 200% of the initial specified value</td> <td>φ D≤6.3</td> <td>8000</td> </tr> <tr> <td rowspan="2">漏电流 Leakage current</td> <td rowspan="2">≤初始规格值 The initial specified value</td> <td>φ D≥8&10</td> <td>10000</td> </tr> <tr> <td>φ D≥12.5</td> <td>12000</td> </tr> </table> | 静电容量变化率 Capacitance change | ≤初始值的±25% (10V: ≤±30%) ± 25% of the initial value (10V: ≤±30%) | 直径 dia | 寿命 (小时) Load Life (hours) 10~120V | 损失角正切值 D.F. tan δ | ≤初始规格值的 200% 200% of the initial specified value | φ D≤6.3 | 8000 | 漏电流 Leakage current | ≤初始规格值 The initial specified value | φ D≥8&10 | 10000 | φ D≥12.5 | 12000 | | |
| 静电容量变化率 Capacitance change | ≤初始值的±25% (10V: ≤±30%) ± 25% of the initial value (10V: ≤±30%) | 直径 dia | 寿命 (小时) Load Life (hours) 10~120V | | | | | | | | | | | | | | |
| 损失角正切值 D.F. tan δ | ≤初始规格值的 200% 200% of the initial specified value | φ D≤6.3 | 8000 | | | | | | | | | | | | | | |
| 漏电流 Leakage current | ≤初始规格值 The initial specified value | φ D≥8&10 | 10000 | | | | | | | | | | | | | | |
| | | φ D≥12.5 | 12000 | | | | | | | | | | | | | | |
| <p>高温贮存 Shelf life</p> | <p>在 105℃环境中, 无负荷放置 1000 小时后、待温度恢复到 20℃进行测量时, 应满足以下要求。 The following specifications shall be satisfied when the capacitors are restored to 20℃ after exposing them for 1,000 hours at 105℃ without voltage applied.</p> <table border="1" style="width: 100%; border-collapse: collapse;"> <tr> <td style="width: 50%;">静电容量变化率 Capacitance change</td> <td style="width: 50%;">≤初始值的±25% (10V: ≤±30%) Initial measured value</td> </tr> <tr> <td>损失角正切值 Dissipation factor</td> <td>≤初始规格值的 200% 200% of the initial specified value</td> </tr> <tr> <td>漏电流 Leakage current</td> <td>≤初始规格值的 200% 200% of the initial specified value</td> </tr> </table> | 静电容量变化率 Capacitance change | ≤初始值的±25% (10V: ≤±30%) Initial measured value | 损失角正切值 Dissipation factor | ≤初始规格值的 200% 200% of the initial specified value | 漏电流 Leakage current | ≤初始规格值的 200% 200% of the initial specified value | | | | | | | | | | |
| 静电容量变化率 Capacitance change | ≤初始值的±25% (10V: ≤±30%) Initial measured value | | | | | | | | | | | | | | | | |
| 损失角正切值 Dissipation factor | ≤初始规格值的 200% 200% of the initial specified value | | | | | | | | | | | | | | | | |
| 漏电流 Leakage current | ≤初始规格值的 200% 200% of the initial specified value | | | | | | | | | | | | | | | | |

六、试验方法及要求 Tests

| 项目 Item | 试验条件 Test Conditions | 性能要求 Requirements |
|--|--|---|
| 浪涌电压 Surge Voltage | 温度+15~+35℃，施加规定的浪涌电压，充电30秒，放电5分30秒，共循环1000次。 At +15~+35℃, applying the Us 1000 cycles of 30s on and 330s off. | 无可见损伤及电解液漏出 No visible damage, no leakage of electrolyte |
| | | $\Delta C/C$ $\leq \pm 15\%$ 初始测量值 Initial measured value |
| | | $tg \delta$ \leq 初始规定值 Initial specified value |
| | | I \leq 初始规定值 Initial specified value |
| 耐久性 Load Life | 在105℃环境中,连续加载额定直流电压与额定纹波电流(所加电压峰值不超过额定工作电压)规定时间后,待温度恢复到20℃进行测量时,应满足以下要求。The following specification shall be satisfied when the capacitors are restored to 20℃ after subjected to DC voltage with the rated ripple current is applied for the specified period of time at 105℃ | 无可见损伤及电解液漏出,标志清晰。No visible damage, no leakage of electrolyte, marking legible. I |
| | | $\Delta C/C$ \leq 初始值的 $\pm 25\%$ (10V: $\leq \pm 30\%$) Initial measured value |
| | | $tg \delta$ \leq 初始规格值的200% 200% of the initial specified value |
| | | I \leq 初始规定值 Initial specified value |
| 高温贮存 Shelf Life | 在105℃环境中,无负荷放置1000小时后、待温度恢复到20℃进行测量时,应满足以下要求。The following specifications shall be satisfied when the capacitors are restored to 20℃ after exposing them for 1,000 hours at 105℃ without voltage applied. | 无可见损伤及电解液漏出 No visible damage, no leakage of electrolyte |
| | | $\Delta C/C$ \leq 初始值的 $\pm 25\%$ (10V: $\leq \pm 30\%$) Initial measured value |
| | | $tg \delta$ \leq 初始规格值的200% 200% of the initial specified value |
| | | I \leq 初始规格值的200% 200% of the initial specified value |
| 引出端强度 Tension Strength | IEC 68-2 试验 Ua: 拉力10N, 10秒 IEC 68-2 Test Ua: Loading force 10N for 10s | 无可见损伤且标志清晰 No visible damage; marking legible. |
| 可焊性 Solder ability | IEC 68-2 试验 Ta: 焊料槽温度为235±5℃, 浸渍深度占整个引出线的90%, 浸渍持续时间为2.0±0.5秒。 IEC 68-2 Test Ta: Tank temperature: 235±5℃; Impregnating depth: $\geq 90\%$ of the total lead wire; Impregnating time: 2.0±0.5 s. | 引出端的良好镀层, 焊料自由流动, 引出端湿润。 The lead wire is coated by tin and wet. |
| 耐焊接热 Resistance to soldering heat | IEC 68-2 试验 Tb 方法 1A: 焊料槽温度为260±5℃, 浸渍深度6mm, 浸渍持续时间为10秒。 IEC 68-2 Test Tb means 1A: Tank temperature: 260 ± 5 °C ; Impregnating depth: 6mm; Impregnating time: 10s. | 无可见损伤, 标志清晰, 电容量变化率 $\leq \pm 10\%$ 。 No visible damage; marking legible; $\Delta C/C \leq \pm 10\%$ |
| 绝缘外套的电阻 The insulation resistance of the sleeve | 把一条金属箔紧紧缠在电解电容器本体整个长度上, 金属箔与电解电容器引出端之间的间隙不小于0.5mm。金属箔从两端至少各伸出5mm。电解电容器两端的箔不得折向电解电容器的端部。将100V±5V的直流电压施加在金属箔与电解电容器相连的引线上, 保持1min, 测量绝缘电阻。 | 电解电容器绝缘外套的绝缘电阻值要求不能低于100MΩ。 |

| <p>耐振性 Resistance to vibration</p> | <p>IEC 68-2 试验 Fc: 频率范围 10~55Hz, 振幅为 0.75mm, 持续时间为 3×2 小时。 IEC 68-2 Test Fc ; Frequency: 10 ~ 55Hz; Amplitude: 0.75mm; 3 direction, 2 hours per direction.</p> | <p>无可见损伤和电解液漏出, 且标志清晰, 电容量变化率 ≤±5%。 No visible damage; no leakage of electrolyte; marking legible; ΔC/C≤±5%。</p> | | | | | | | | | | | | | | | | |
|--|--|--|----------------|---------|---------|------------|---|--------------|--|--------------|----------------------------------|--|---------------------|--|--------------|--|---------------|--|
| <p>温度循环试验 Change of temperature test</p> | <p>Temperature Cycle: 电容器应放在烤箱里, 根据一下条件: Capacitor shall be placed in an oven, the condition according as below:</p> <table border="1" data-bbox="411 555 1066 869"> <thead> <tr> <th>温度 Temperature</th> <th>时间 Time</th> </tr> </thead> <tbody> <tr> <td>(1)+20℃</td> <td>≤3 Minutes</td> </tr> <tr> <td>(2)额定最低温度 (-40℃) Rated low temperature(-40℃)</td> <td>30±2 Minutes</td> </tr> <tr> <td>(3)额定最高温度 (+105℃) Rated high temperature(+105℃)</td> <td>30±2 Minutes</td> </tr> <tr> <td colspan="2">(1)to (3)=1 cycle, total 5 cycle</td> </tr> </tbody> </table> <p>特征应满足下列要求 The characteristic shall meet the following requirement.</p> <table border="1" data-bbox="411 952 1129 1205"> <tbody> <tr> <td>漏电流 Leakage current</td> <td>不超过规定值 Not more than the specified value.</td> </tr> <tr> <td>损耗角正切值 tan δ</td> <td>不超过规定值 Not more than the specified value.</td> </tr> <tr> <td>外观 Appearance</td> <td>应当有电解液无泄漏 There shall be no leakage of electrolyte.</td> </tr> </tbody> </table> | | 温度 Temperature | 时间 Time | (1)+20℃ | ≤3 Minutes | (2)额定最低温度 (-40℃) Rated low temperature(-40℃) | 30±2 Minutes | (3)额定最高温度 (+105℃) Rated high temperature(+105℃) | 30±2 Minutes | (1)to (3)=1 cycle, total 5 cycle | | 漏电流 Leakage current | 不超过规定值 Not more than the specified value. | 损耗角正切值 tan δ | 不超过规定值 Not more than the specified value. | 外观 Appearance | 应当有电解液无泄漏 There shall be no leakage of electrolyte. |
| 温度 Temperature | 时间 Time | | | | | | | | | | | | | | | | | |
| (1)+20℃ | ≤3 Minutes | | | | | | | | | | | | | | | | | |
| (2)额定最低温度 (-40℃) Rated low temperature(-40℃) | 30±2 Minutes | | | | | | | | | | | | | | | | | |
| (3)额定最高温度 (+105℃) Rated high temperature(+105℃) | 30±2 Minutes | | | | | | | | | | | | | | | | | |
| (1)to (3)=1 cycle, total 5 cycle | | | | | | | | | | | | | | | | | | |
| 漏电流 Leakage current | 不超过规定值 Not more than the specified value. | | | | | | | | | | | | | | | | | |
| 损耗角正切值 tan δ | 不超过规定值 Not more than the specified value. | | | | | | | | | | | | | | | | | |
| 外观 Appearance | 应当有电解液无泄漏 There shall be no leakage of electrolyte. | | | | | | | | | | | | | | | | | |
| <p>防爆试验 Safety Vent</p> | <p>以下试验只适用于铝壳直径≥φ8 产品。 The following tests only apply to those products with vent products at diameter ≥ φ 8 with vent. 在电容器两极施加反向工作电压, 其中通过的电流为 1A, 在测试时防爆装置应能在 30 分钟内动作。 D. C. Application test The capacitor shall be subjected to a reverse D.C. voltage equal to the D.C. voltage. The current flowing through capacitor shall be 1A.If the vent does operate with the voltage applied for 30 minutes, the test is considered to be passed.</p> | <p>上述过程中应无引线、铝箔等散射, 无火花产生。 The vent device is actuated under the test conditions, thereby preventing terminals, metal pieces, etc, of the capacitor from scattering due to burst, the case from separating from the seal packing, or the capacitor from producing flame.</p> | | | | | | | | | | | | | | | | |
| <p>自然放置下的储存规定 The provisions of storage under Natural placed</p> | <p>1、环境温度: -10~35℃, 环境湿度: <75%RH; 2、产品储存期限为 12 个月; 3、产品储存期限>12 个月, 需送回工序重新老化; 4、存放时间超过 3 年的电解电容器应立即报废, 不可再使用; 5、库存有效期以产品套管上印刷的时间开始计算。 1、Ambient temperature: -10~35℃, Ambient humidity: <75%RH; 2、Storage time: 12 months; 3、Storage time>12 months, need ageing again;</p> | | | | | | | | | | | | | | | | | |

| | |
|--|--|
| | <p>4、Storage time > three years, need to be discarded;</p> <p>5、Expiry Date: With products marked on time to start calculation.</p> |
|--|--|

七、构造图及材料表 Frame drawing and materials

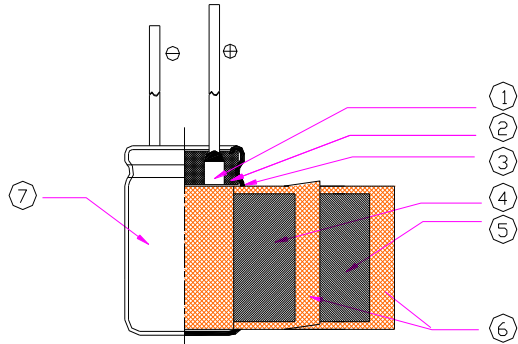

| 序号 No. | 部件名称 Parts | 材料名称 Material | 主要供应厂家名称 Main supply Factory |
|-----------|------------------|--|---------------------------------|
| 1 | 引出线 | 铝线 LG3+镀锡铜钢线 AL- wire LG3+Tin- plating of copper cover steel | |
| 2 | 橡胶塞 | 丁基胶 I.I.R | |
| 3 | 铝壳 AL- case | 99.5%纯度铝 AL -99.5% | |
| 4 | 阳极箔 AL – foil(+) | 99.99%或 99.98% 形成铝箔 Formed AL 99.99% or 99.98% | |
| 5 | 阴极箔 AL – foil(-) | 99.4% 腐蚀铝箔 Formed AL 99.4% | |
| 6 | 电解纸 Separators | 电解电容器纸 Electrolytic Capacitor paper | |
| 7 | 套管 Sleeve | P.E.T (Poly vinyl chloride) | |
| 8 | 电解液 Electrolyte | 化学试剂 Chemical | |

八、标志 Marking

