

Production in Romania

Production in China

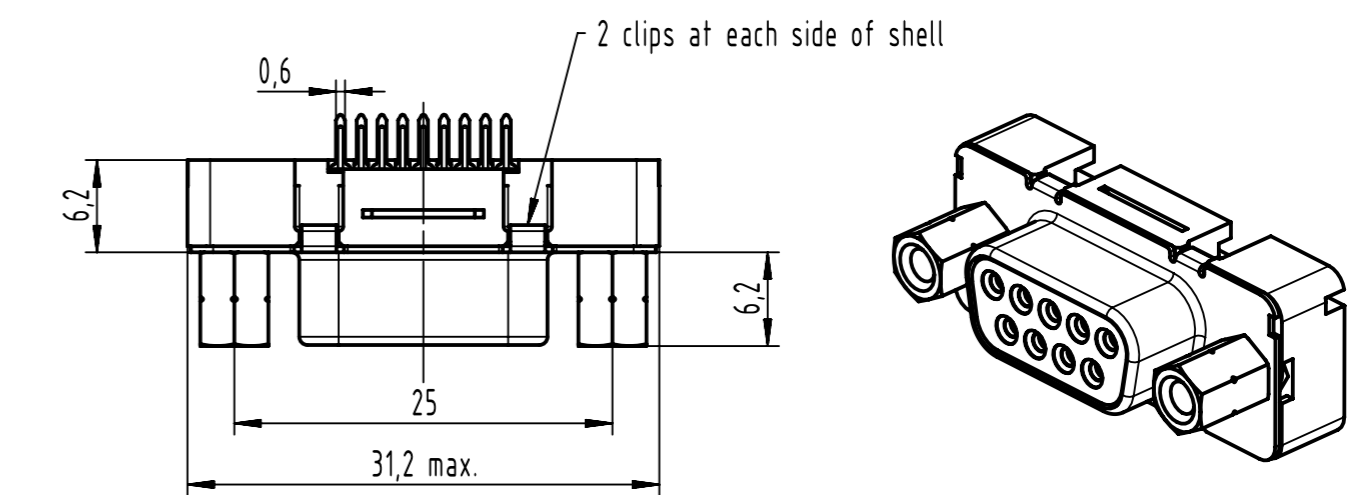
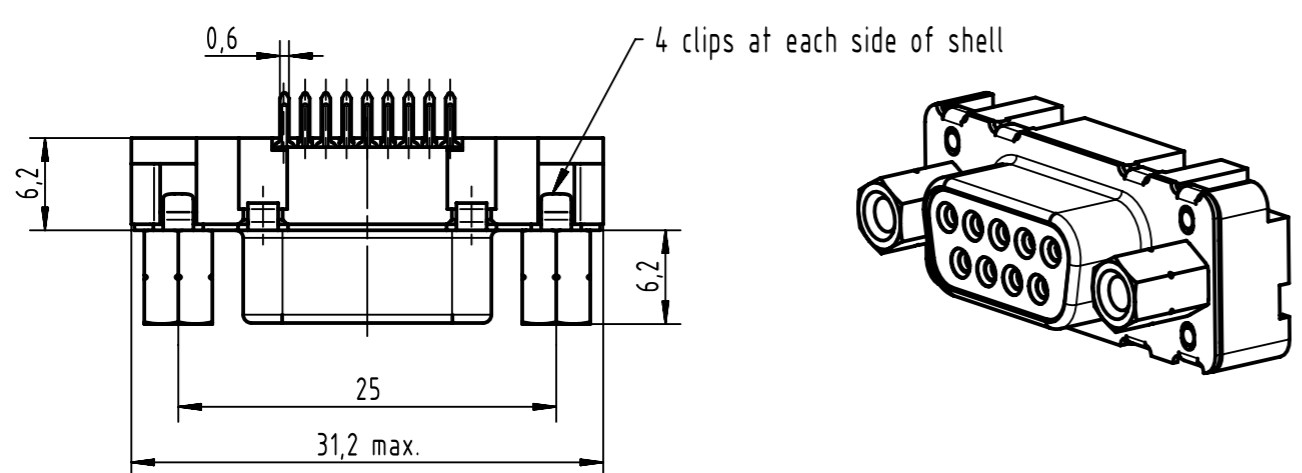
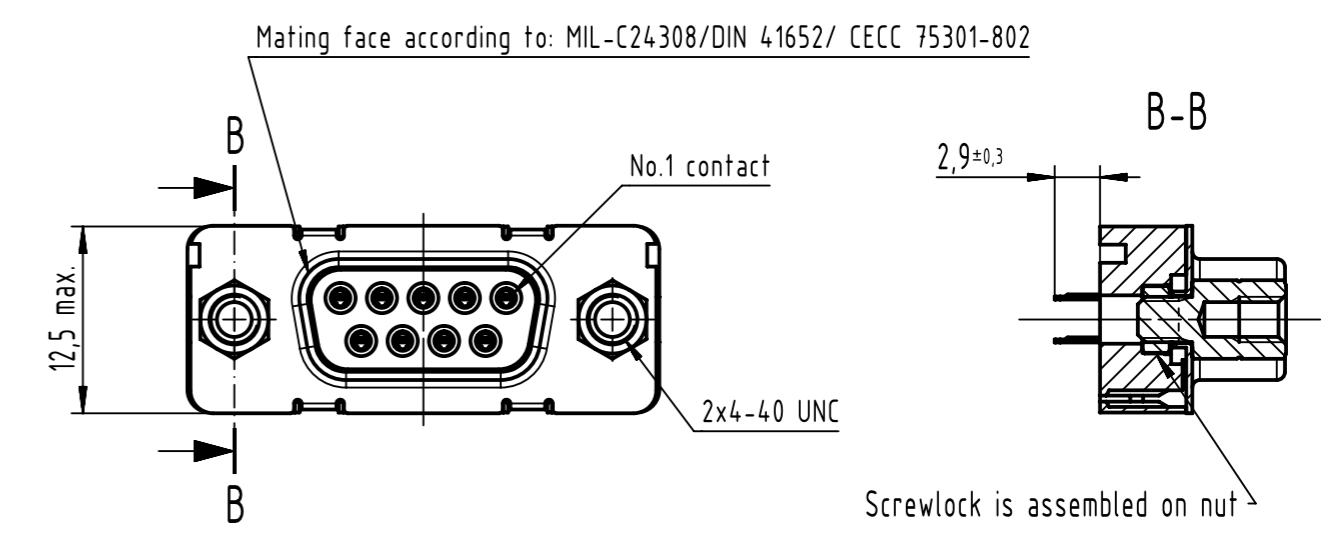
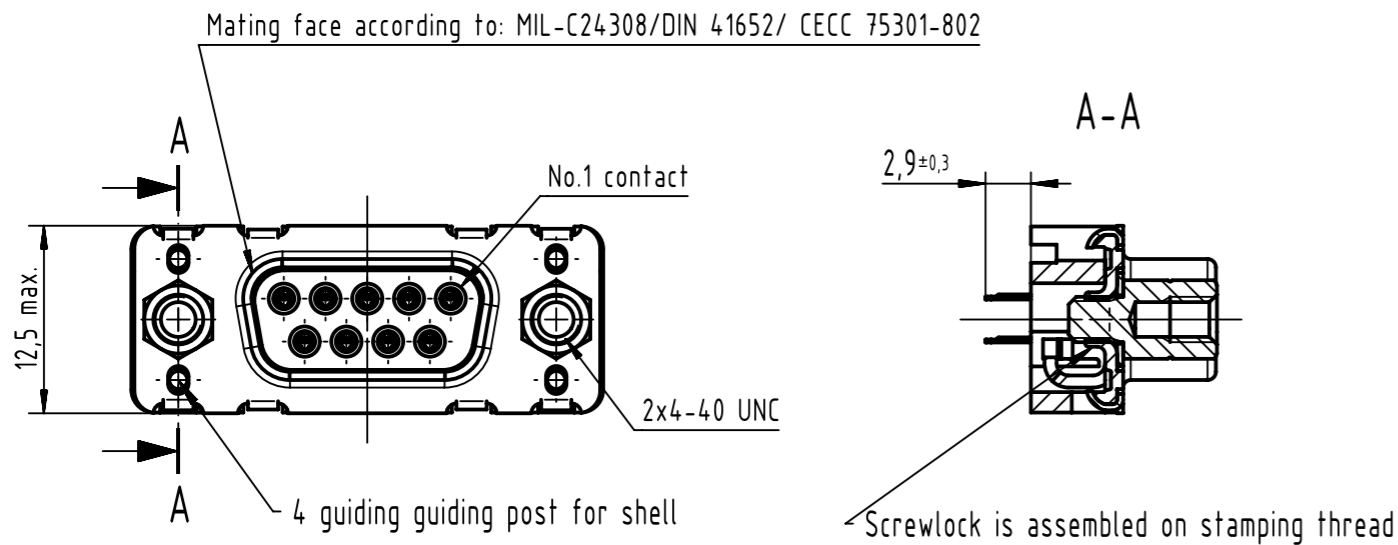

Plating for metal shell: Ni over Cu

Plating for metal shell: Sn over Ni with Cu under plating

Printed board layout component side

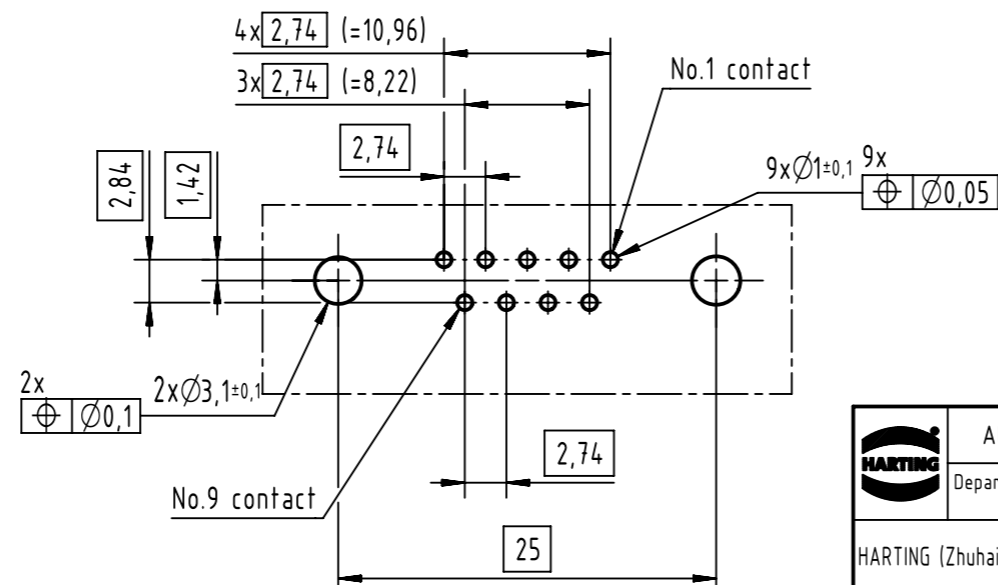

0966 111 3503	1
0966 111 6503	2
0966 111 7503	3
Part number	Performance level

	All rights reserved	Created by ZHUANGJ	Inspected by LUOK	Standardisation ROEBEN	Date 2022-08-26	State Final Release
	Department EL PD	Title D-Sub str fem 09-pole with solder pin & screw lock				Doc-Key / ECM-Nr. 101025956/UGD/000/A 500000221831
HARTING (Zhuhai) Manufacturing Co., Ltd. 519085 Zhuhai, China		Type TB	Number 09661116503		Rev. A	Page 1/1