

Product Specification

Number: L-KLS3-MWC-12*7.5-C1

Name: Internal driven
Magnetic buzzers

Customer: A05

Date: 2023-12-11

Customer Signature:

--



NINGBO KLS ELECTRONIC CO; LTD

Tel : 0086-574-86828566

Fax : 0086-574-86824882

ADD : NO. 8-1, RONGXIA RD. XIAPU SHANQIAN
INDUSTRIAL ZONE BEILUN NINGBO ZHEJIANG.

Compi	Check	Review	Approva
Jenny	Jack.C		

1.适用范围：本规范适用于L-KLS3-MWC-12*7.5-C1 ROHS蜂鸣器。

This specifications apply the L-KLS3-MWC-12*7.5-C1 ROHS buzzer.

2.基本规格/General specification

项目/Item	规格/Spec	条件/Condition
1 额定电压 Rated voltage	12VDC	
2 工作电压 Operation voltage	8-16VDC	
3 声压 Sound Pressure Level=SPL	Min 87dB	测试环境：标准状态，标准驱动电路， 额定电压 测试距离：0.1m Standard State,Standard Drive Circuit. Rated voltage,Distance at 0.1m
4 电流 current	≤ 30mA	
5 振荡频率 Oscillation frequency	2700±300Hz	
6 响应时间 Response time	Max 50mS	最低工作电压 Lowest operation voltage
7 工作温度范围 Range of operation temperature	-20~+85℃	声压 ≥85dB SPL ≥85dB
8 保存温度范围 Range of preservation temperature	-20~+85℃	
9 端子强度 Terminal strength	10N	拉负荷方向的终端轴 Pull load on the direction of the terminal axis
10 外部尺寸 Externals size	Φ12x7.5	参阅附图 Refer to the attached drawing
11 重量 Mass	2g	

☆标准状态：常温（15~35℃），湿度（25~85%相对湿度），空气压力（860~1060hpa）
在假设的情况判断，测试是一基本状态下进行。

Standard State:Ordinary Temp(15~35℃),Humidity(25~85%RH),Air pressure(860~1060hPa)

In case of doubtful judgment,the test is re—performed under Basic State.

☆基本情况：温度。（20±2℃），湿度（60~70%相对湿度），空气压力（860~1060hpa）

Basic State: Temp.(20±2℃),Humidity(60~70%RH),Air pressure(860~1060hPa)

<标准驱动电路>/<Standard Drive Circuit>

<标准测试治具>/<Standard Test Fixture>

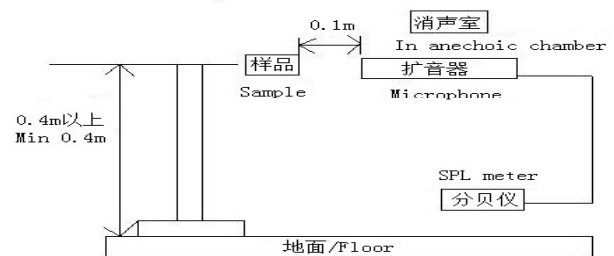
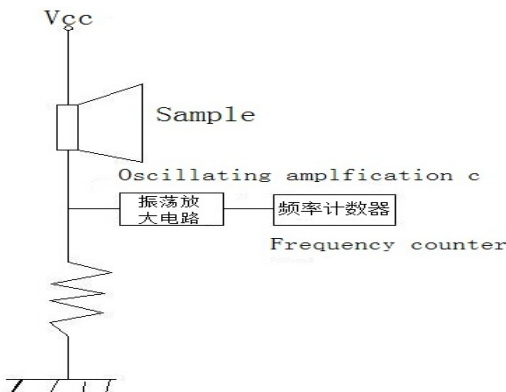

3.可靠性规范/Reliability specification

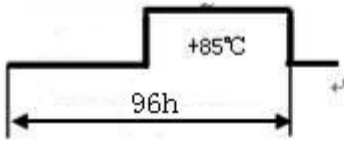
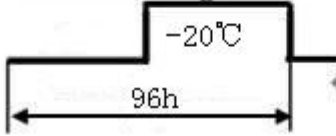
项目/Item	试验条件/Test condition	判断标准/Criteria	引用规格
1 高温保存试验 High temperature Preservation	+85℃环境下放置24小时 Exposure to +85℃ for 24 hrs.	经过测试,符合规格,没有任何不合格的外观和性能 After the test the part shall meet specifications without any degradation.	
2 低温保存试验 Low temperature preservation	-20℃环境下放置24小时 Exposure to -20℃ for 24 hrs.		
3 高温试验 High temperature Shock			
4 低温试验 Low temperature Shock			
5 常温寿命试验 Ordinary Temp. Life	常温 (25℃±10℃) 电压12VDC连续测试48小时 Driving the sounder at 12VDC for 48hrs in the room temperature(25℃±10℃)		
6 高温寿命试验 High Temp. Life	高温 (+85℃) 电压12VDC连续测试2小时 Driving the sounder at 12VDC for 2hrs in the low temperature(+85℃)		
7 低温寿命试验 Low Temp. Life	低温 (-20℃) 电压12VDC连续测试2小时 Driving the sounder at 12VDC for 2hrs in the low temperature(-20℃)		
8 端子拉力试验 Lead strength	10N的拉力在端子上拉10±1秒 Pull load on the direction of the terminal axis for 10±1 sec.		
9 跌落试验 Free drop	70cm高自由掉落到厚40mm的木板上,每个方向一次 Free drop, 70cm height, on wood board (t40mm) X, Y, Z 3Direction 1time each, total 3times.		排除弯曲的针 Exclude bending of Pin
10 端子可焊性试验 Solderability	260±5℃焊接温度。时间: 5±0.5sec。 Temp. 260±5℃ Soaking Time: 5±0.5sec	端子95%必须覆盖着焊料 95% surface of lead pins must be covered with fresh solder and no soldering holes should be found	

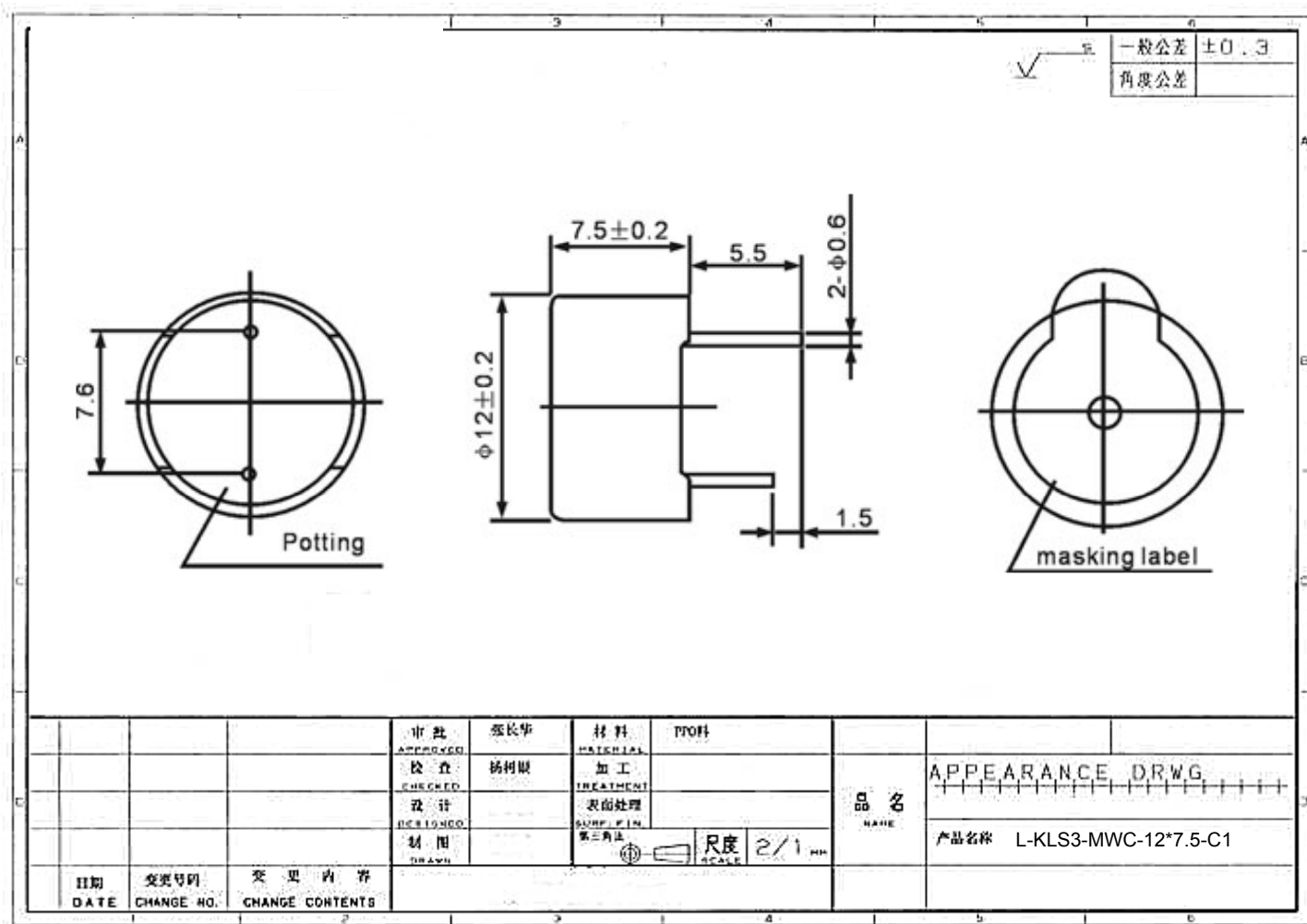

产品特征图

