



# PRODUCT SPECIFICATION

**Model No.: FYLP-1W-IRCCB**

Features:
■ SMD Type
■ Size (mm):15.00*8.00*5.20
■ Emitting Color:Infrared
■ SMT package
■ Suitable for all SMT assembly and soldering method
■ Pb-free Reflow soldering application
■ RoHS Compliant
■ MSL:6

Applications:
■ Light Strips
■ LCD Backlight
■ Decorative lighting
■ Indicators
■ Interior automotive
■ Illuminations
■ Mobile Phones



CUSTOMER APPROVED SIGNATURES	APPROVED BY	SALES BY	PREPARED BY
			

**NINGBO FORYARD OPTOELECTRONICS CO.,LTD.**

**Add:**No. 666 Jinghua Road, Hi-tech Park, Ningbo, Zhejiang, China

**Zip:**315103

**Tel:** 0086-574-87933652 87927870

**Fax:** 0086-574-87927917

**E-mail:**Sales@foryard.com ( General)

Model No.:	FYLP-1W-IRCCB
Date / Rev.	2023.03.16 / A

**Model No.: FYLP-1W-IRCCB**

**■ Mechanical Dimensions**

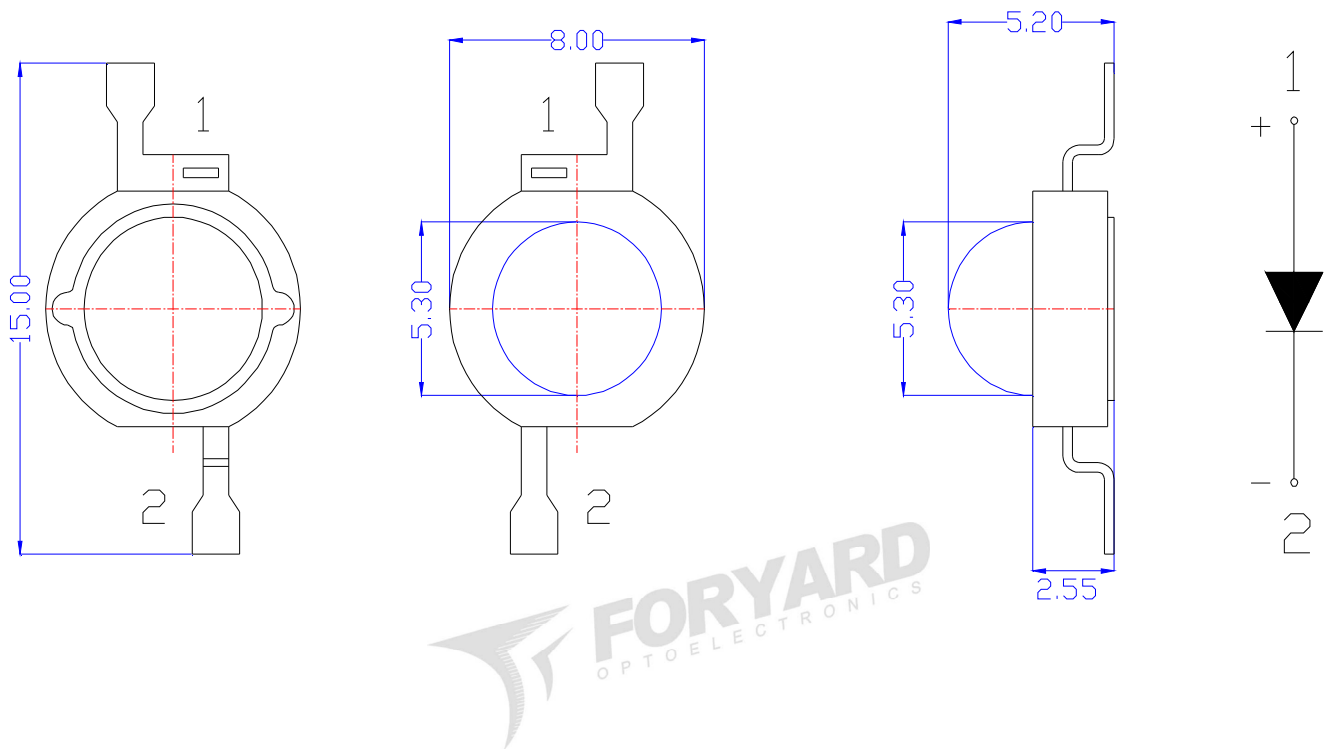

**■ Recommend Soldering pad design(unit=mm)**

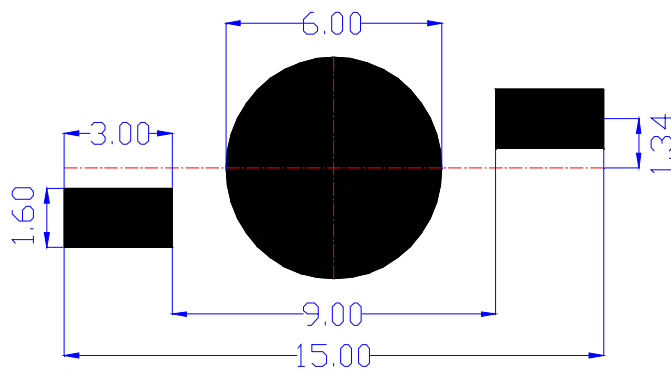

**Notes:**

1. Dimension in millimeter, tolerance is  $\pm 0.10$ .
2. Angle:  $\pm 5^\circ$
3. The specifications, characteristics and technical data described in the datasheet are subject to change without prior notice.
4. The drawing is different from the actual one, please refer to the sample.

**Model No.: FYLP-1W-IRCCB**

**Absolute Maximum Ratings(Ta=25°C)**

Parameter	Symbol	MAX.	Unit
Power Dissipation	PD	1500	mW
Continuous Forward Current	IF	750	mA
Peak Forward Current*	IFP	1200	mA
Reverse Voltage	VR	5	V
Operating Temperature Range	Topr	-25~ +80	°C
Storage Temperature Range	Tstg	-25~ +100	°C

\*1/10 Duty Cycle, 0.1ms Pulse Width

**Typical Electrical & Optical Characteristics(Ta=25°C)**

Parameter	Symbol	Test Condition	Min.	Typ.	Max.	Unit
Radiant Intensity	Ee	IF=600mA	280	330	---	mW/sr
Forward Voltage	VF	IF=600mA	1.5	1.7	2	V
Dominant Wavelength	$\lambda_d$	IF=600mA	840	855	865	nm
Spectral Line Half-Width	$\Delta\lambda$	IF=600mA	---	40	---	nm
Backward Voltage	IR	VR = 5V	---	---	10	$\mu$ A
Viewing Angle	$2\theta_{1/2}$	IF=600mA	---	120	---	Deg

**Material**

Item	Reflector	Wire	Encapsulate	Chip
Material	PPA	Gold	Silicon	AlGaAs

Note:

- 1.Luminous Intensity is based on the Foryard standards.
- 2.Pay attention about static for InGaN

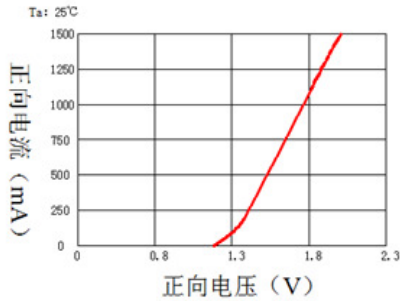
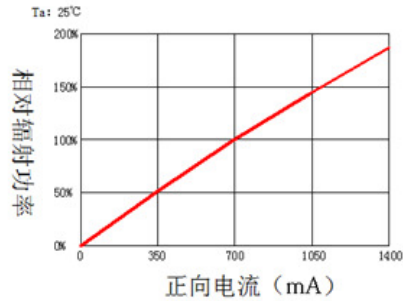
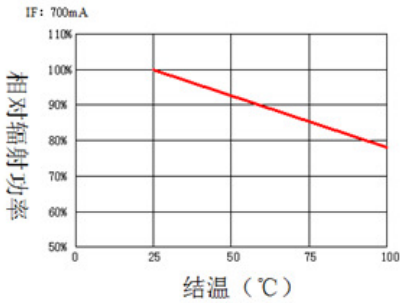
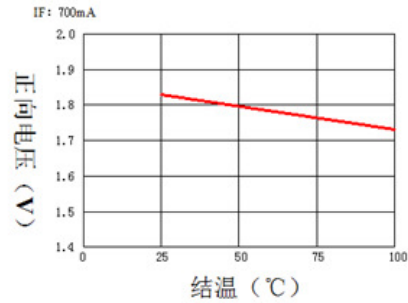
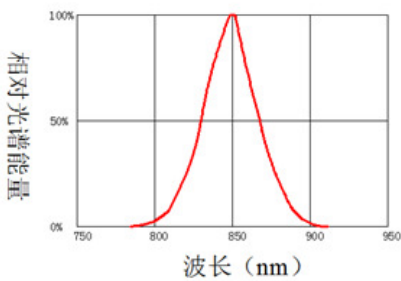
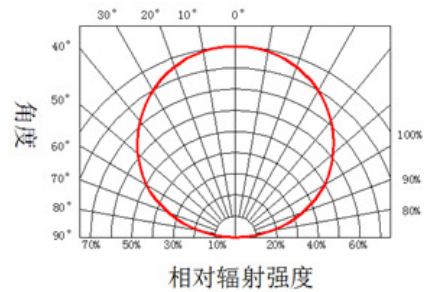
**Model No.: FYLP-1W-IRCCB**
**Electrical-Optical Characteristics-**
**正向电压VS正向电流曲线**

**正向电流VS相对辐射功率曲线**

**结温VS相对辐射功率曲线**

**结温VS正向电压曲线**

**波长VS相对光谱能量曲线**

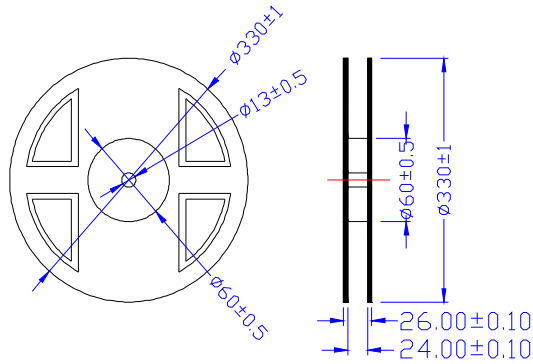
**相对辐射强度VS角度曲线**

NOTE:25°C free air temperature unless otherwise specified

**Model No.: FYLP-1W-IRCCB**

■ **Package-**

1. Reel Dimension



2. Tape Dimension

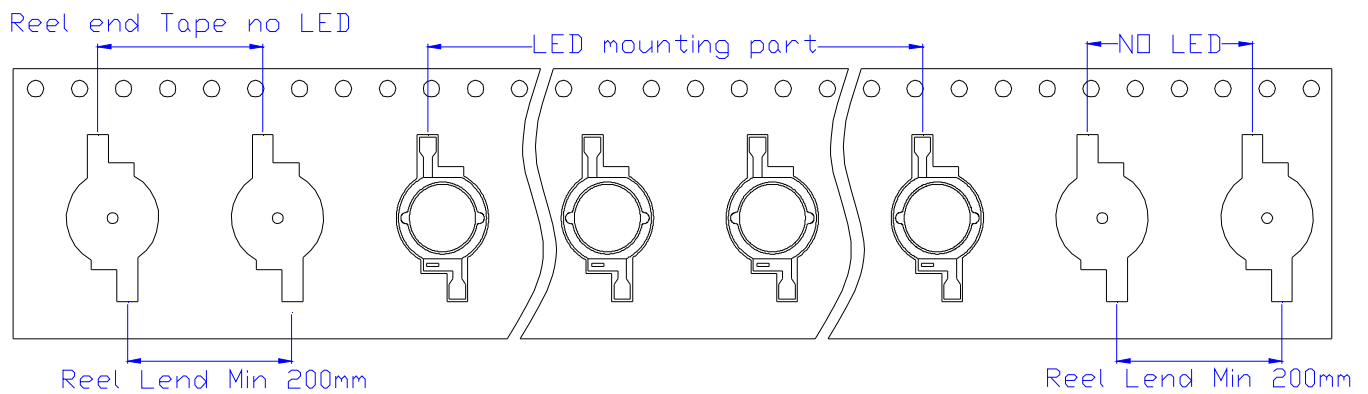
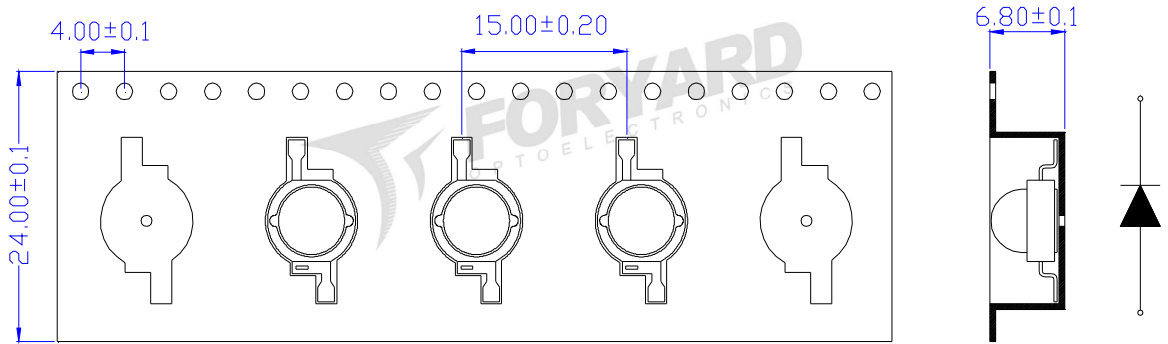

Notice:

1. Tolerance unless mentioned is  $\pm 0.2\text{mm}$

Model No.:	FYLP-1W-IRCCB
Date / Rev.	2023.03.16 / A

**Model No.: FYLP-1W-IRCCB**

3. Packing Diagram

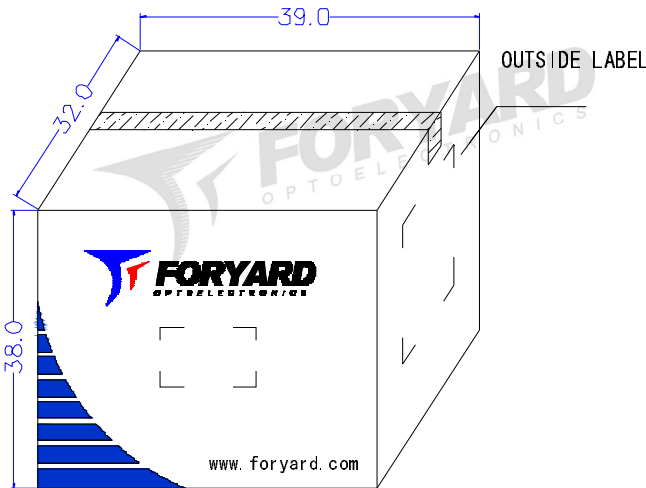
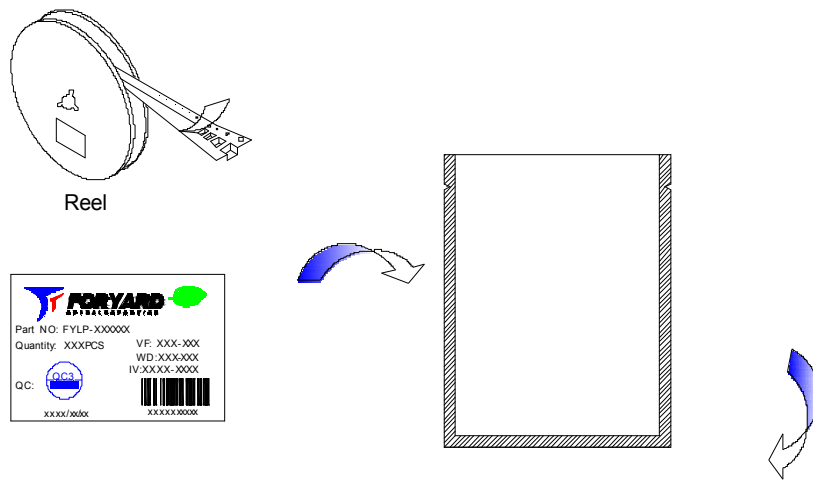

10 Reel/Carton

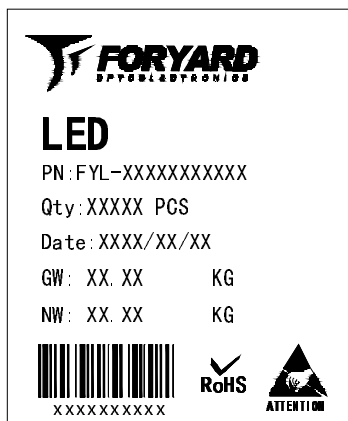

OUTSIDE LABEL

Notice:

- 1.Quantity:1000 PCS/Reel
- 2.The specifications are subject to change without notice. Please contact us for updated information.

**Model No.: FYLP-1W-IRCCB**

**■ Soldering Characteristics-**

**● Reflow Soldering**

**● Lead Solder**

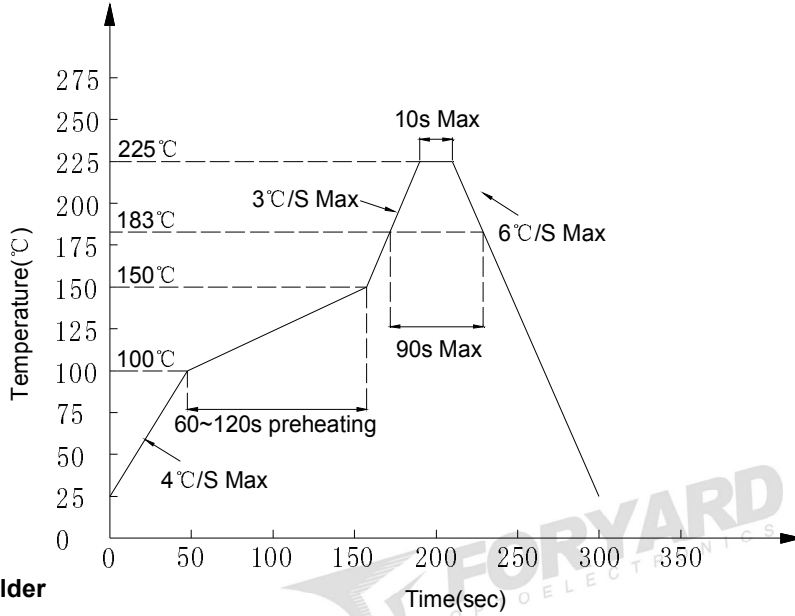

**● Lead-free Solder**

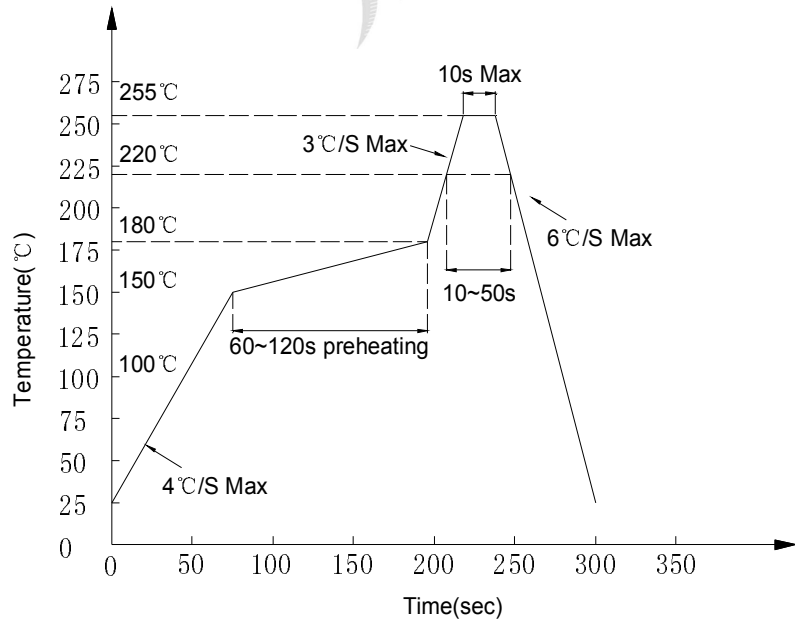

**Notes:**

1. Although the recommended soldering conditions are specified in above table, reflow or hand soldering at the lowest possible temperature is desired for the LEDs.
2. A rapid-rate process is not recommended for cooling the LEDs down from the peak temperature.
3. All temperatures refer to solder Pad.

**● Hand Soldering**

Soldering temperature	300°C Max. (25W Max.)	One time only
Soldering time	5 ±1sec	

**Model No.: FYLP-1W-IRCCB**

**■ Handling of Silicone Resin LEDs-**

**● Handling Indications**

When handling the product, do not touch it directly with bare hands as it may contaminate the surface and affect on optical characteristics. In the worst cases, excessive force to the product might result in catastrophic failure due to package damage and/or wire breakage.

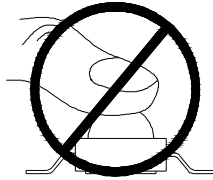

When handling the product with tweezers, LEDs should only be handled from the side and make sure that excessive force is not applied to the resin portion of the product. Failure to comply can cause the resin portion of the product to be cut, chipped, delaminated and/or deformed, and wire to be broken, and thus resulting in catastrophic failure.



**■ Recommended circuit-**

• In designing a circuit, the current through each LED must not exceed the absolute maximum rating specified for each LED. It is recommended to use Circuit B which regulates the current flowing through each LED. In the meanwhile, when driving LEDs with a constant voltage in Circuit A, the current through the LEDs may vary due to the variation in forward voltage (VF) of the LEDs. In the worst case, some LED may be subjected to stresses in excess of the absolute maximum rating.

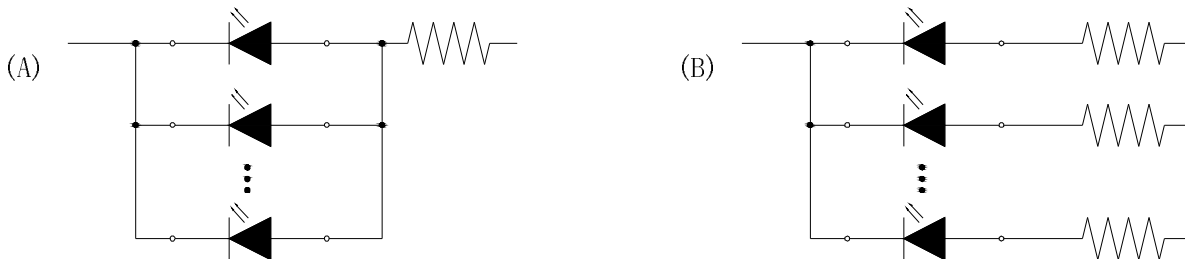

• This product should be operated in forward bias. A driving circuit must be designed so that the product is not subjected to either forward or reverse voltage while it is off. In particular, if a reverse voltage is continuously applied to the product; such operation can cause migration resulting in LED damage.

**■ Storage-**

**● Storage Conditions**

1. Unopened moisture barrier bag (MBB) shall be stored at temperature below 5°C~30°C, with humidity below 60%RH.
2. Before the MBB be opened, check if have the air leakage, if have, then need to bake at 65°C~70°C for 24hours.
3. After the MBB has been opened, the LEDs which need for reflow soldering or other soldering methods, must be used according to below:
  - a: Must finish the soldering in 12hours
  - b: Stored with the humidity below 30%RH
  - c: If not finish the soldering in 12hours, need to bake the LED again at 65°C~70°C for 24hours