

APPROVAL SHEET

Customer: Ozdisan

Customer Part NO. _____

Part NO. HZ450M681P450E99YS0A





Item: 680uF/450V

Catalog Series: HZ Series

Date of Issue: SEP.20.2023

Approved NO. : SD20230900547

BUYER'S STAMP	Approved by			

Su' scon	Submitted by			
	Approval	Check	Affirm	Design
				

Su'scon
Electrolytic Capacitor

www.su-scon.com



Taipei - Kuan Kun Electronic Enterprise Co., Ltd.
Tel: 886-2-82269699 Fax: 886-2-82269670
China - DongGuan Kuan Kun Electronic Co., Ltd.
Tel: 86-769-87318000 Fax: 86-769-87318008
HongKong - Kuan Kun Investment (H.K) Co., Ltd.
Tel: 852-23857603 Fax: 852-23858725
China - DongGuan Kuan Yi Electronic Co., Ltd.
Tel: 86-769-39019168 Fax: 86-769-39019167



RECORD OF REVISION

NO.	VERSION	REASON	DATE	CHECKED	REMARKS
1	A00	First Release	2023.09.20	王代燕	
2					
3					
4					
5					
6					
7					
8					
9					
10					
11					
12					
13					
14					
15					
16					
17					
18					
19					
20					
21					
22					
23					
24					
25					
26					
27					
28					
29					
30					

HZ Specification For Approval

NO.	Customer Part No.	Specification	<i>Su' scon</i> Part No.
1		EC,680uF/450V	HZ450M681P450E99YS0A
1			
2			
3			
4			
5			
6			
7			
8			
9			
10			
11			
12			
13			
14			
15			
16			
17			
18			
19			
20			
21			
22			
23			
24			

Explanation of Parts Numbers (ERP System)

Draw Up:1999.12.15
Revise:2016.06.15
Codification:DKK/III-00-002
Edition:A08

Explanation of Parts Numbers

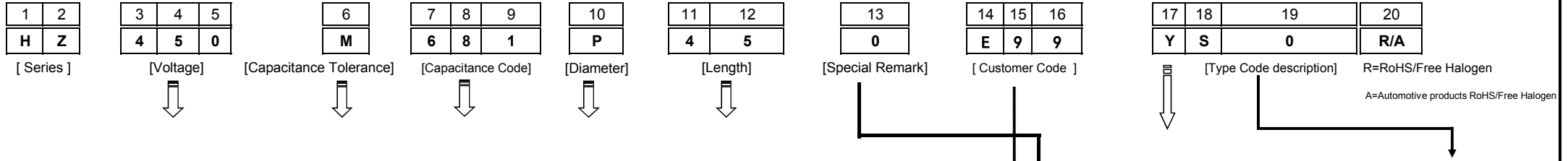

004=4V	J= ±5 %	0R1=0.1uF	C=4Φ
006=6.3V	K= ±10%	1R0=1uF	D=5Φ
010=10V	M= ±20 %	100=10 uF	5=5.5Φ
016=16V	A= 0 %~+20 %	101=100 uF	E=6.3Φ
025=25V	S= 0 %~+40 %	102=1000 uF	V=6.5Φ
035=35V	R= 0 %~+50 %	103=10000 uF	F=8Φ
050=50V	D= -5 %~+20 %	223=22000 uF	G=10Φ
063=63V	V= -10 %~+20 %	G52=1650 uF	H=12Φ
080=80V	Q= -10 %~+30 %		X=12.5Φ
100=100V	T= -10 %~+50 %	P=35Φ	I=13Φ
160=160V	E= -15 %~+20 %	Q=40Φ	Y=14.5Φ
350=350V	I= -30 %~+20 %	W=42Φ	J=16Φ
400=400V	B= +10 %~+30 %	8=45Φ	K=18Φ
420=420V	N= +10 %~+25 %	R=51Φ	L=20Φ
450=450V	C= -5 %~+15 %	S=64Φ	M=22Φ
500=500V	Z= -0 %~+30 %	T=76Φ	N=25Φ
		U=90Φ	Z=25.4Φ
		B=100Φ	O=30Φ

1) Length < 100mm Integer, Input it direct.

2) Length < 100mm Decimal, Please refer the code as below: Ex:11.5 isBB; 5.4 is 5A;

3. Length ≥ 100mm, First digit input No.0~9 · 2nd · 3rd refer as below Code11 Ex:115, Input B5.

Code 11 · 18	Meaning
A	10
B	11
C	12
D	13
E	14
F	15
G	16
H	17
I	18
J	19
K	20
Q	21

Code 12 · 19	Meaning
A	0.4
B	0.5
C	0.6
D	0.7
E	0.8
F	0.9
G	0.1
H	0.2
I	0.3

Code	Meaning
B	Forming Only
C	Lead Cut
D	Lead Cut and Crimp
N	Lead spacing expand to 2.0 mm then Cut
E	Lead spacing expand to 2.5 mm then Cut
F	Lead Forming spacing 5.0 mm then Cut
H	Lead Forming Cut and Crimp
S	Long Lead
L	Facing cathode: Lead Cut and Bending (turn right)
Z	Facing cathode: Lead Cut and Bending (turn left)
P	Taping (Ammo pack)
R	Tape and Reel
V	V-chip Type (SMD)
G	LG Type Terminal
PCS	PC board pin-out Straight Terminal
PCY	PC board pin-out LUG Terminal
PCU	PC board pin-out U-Insert Terminal
PCB	PC board pin-out Bend Terminal
ST	Straight Type Terminal
U	5 Pin Straight Terminal
W	Screw Terminal
YL	Snap

Code 13	Meaning
T	Convex Rubber seal {Standard : Lead Type 12.5Φ ≤ D ≤ 18Φ (Breathe freely)}
P	Flat Rubber seal {Standard : Lead Type 4Φ ≤ D ≤ 12Φ : 20Φ · 22Φ · 25Φ}
0	Snap-in, U-LUG Type

KKK	For Standard Product which has no artfactitious. (Bulk, Long-lead, No particular processing, rated spec.)
E99	Customer No. (Ozdisan)

2.ERP P/N System compare with NCC's Description

- "Finished Products" ----20 Codes ·
- Snap in Type---- "Semi-finished products P/N" has not demand · It's also 20 Codes
- Lead Type---- 16 codes for "Semi-finished products" · It's 16 codes (If Specially enquire and 16 codes can not be reached, It will be 20 code for that)
- Codes No.13 : Specially Code · It's difference between clients enquire and same Spec multiple enquired.
- Codes No.14~16 which is for clients Code.
- Length of Lead Cut and Forming bigger than 10.0mm or appendix digit · Letters Description ·

DONG GUAN KUAN KUN ELECTRONIC CO., LTD
 YIN HE INDUSTRIAL ZONE, QING XI TOWN, TEL: 86-769- 87318000
 DONG GUAN CITY, GUAN DONG CHINA (P.R.O.C) FAX: 86-769- 87318008
FOR APPROVAL

DIMENSIONS(mm)

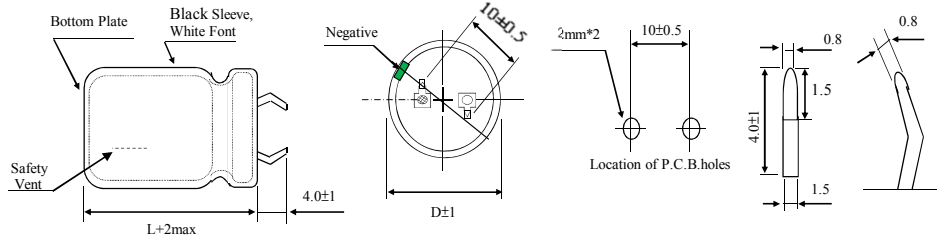

Customer :		Electrolytic Capacitors										
Ozdisan		HZ Series										
Electric Characteristics:												
Ozdisan	Su'scon	Cap.	Cap.	Rate	Surge	Oper.	Nominal	Leakage	D.F.	Max.Ripple	ESR	Load
P/N	P/N	(uF)	Tol.	Volt.	Volt.	Temp.	Case Size	Current	Max	Current	120 Hz	Life
		(%)	(V-DC)	(V-DC)	(°C)	D*L(mm)	Max(uA)	(%)	(A)	at 25°C (Ω)Max	(Hours)	
	HZ450M681P450E99YS0A	680	±20	450	500	105	35*45	1659	20	2.70	0.350	3000

REMARKS:

1. Leakage Current Test: at 20°C for 5 minutes .

2. Operating temperature: 450V -40°C~ + 105°C.

3. Dissipation Factor Test: at 20°C, 120Hz.

4. Capacitance Test: at 20°C, 120Hz.

5. Ripple Current Test: at 105°C, 120Hz .

6. Load Life: 3000 hours,subjected to DC voltage with the rated ripple current is applied at 105°C.

Capacitance Change: Within ±20% of initial value;

tanδ: 200% or less of initial specified value;

Leakage Current: Initial specified value or less;

7. Shelf Life: The following specifications shall be satisfied when the capacitors are restored to 20°C after exposing them for 1000 hours 105°C without voltage applide. Before the measurement, the capacitor shall be preconditioned by applying voltage according to them 4.1 of JIS C5101-4.

Capacitance Change : Within ±15% of initial value;

tanδ: 200% or less of initial specified value;

Leakage Current: Initial specified value or less.

8. when have characteristic requested : Load life & shelf life test and etc. , judgment standard reference to our catalogue.

●SPECIFICATION

Leakage Current 洩漏電流	$I \leq 3\sqrt{CV}(\mu A)$, which is greater. (After 5 minutes application of working voltage)											
Dissipation Factor 散逸因素 (損失角) (tan δ)	Measurement Frequency:120Hz. Temperature: 20°C											
	Rate Voltage(V)	16	25	35	50	63	80	100	160	200~250	350~500	
	tan δ (MAX)	0.50	0.45	0.40	0.35	0.30	0.25	0.20	0.15	0.15	0.20	
When nominal capacitance over 1000μF, tanδ shall be added 0.01 to the listed value with increase of every 1000μF .												
Standards 參照標準	AEC-Q200											

●RIPPLE CURRENT COEFFICIENTS

Frequency coefficient of allowable ripple current					
Rated Voltage(V)	Frequency(Hz)				
	50	120	1k	10k	100k
16~100	0.88	1.00	1.05	1.10	1.15
160~250	0.85	1.00	1.20	1.30	1.50
350~500	0.88	1.00	1.20	1.25	1.40

The endurance of capacitors is reduced with internal heating produced by ripple current at the rate of halving the lifetime with every 5°C rise. When long life performance is required in actual use, the rms ripple current has to be reduced.

一. Scope 適用範圍：

This specification applies to aluminium electrolytic capacitor, used in electronic equipment.

本說明對於用電子儀器設備進行檢測之鋁電解電容器適用。

二. TABLE-TABLE OF METHODS REFERENCED ALUMINUM ELECTROLYTIC CAPACITORS

表-铝电解电容器参考方法

NO.	Stress 应力方式	Reference 参考方法	Additional Requirements 附加要求	SPECIFICATION 規格
1	Pre- and Post-Stress Electrical 应力测试 前后电气测试	User spec.用户规格	Test is performed except as specified in the applicable stress reference and the additional requirements in Table 3.需进行测试，除了适用的应力测试标准和表3中的附加要求指定之外。	In the experimental report 分布在試驗報告中
3	High Temperature Exposure (Storage) 高温存储	MIL-STD-202 Method 108	1000 hrs. at rated operating temperature (e.g. 105°C part can be stored for 1000 hrs at 105°C. Same applies for 85°C & 125°C).Unpowered. Measurement at 24±4 hours after test conclusion. 在额定工作温度下放置器件1000小时(例如：105°C的产品可以在105°C下存储1000小时，同样地也适用于85°C和125°C的产品),不通电。试验结束后24±4小时内进行测试。	Capacitance change Tan δ .Rate of change: please have a look at this eries of shelf life standard. less than specified value . Appearance : no abnormal . 容量.損失角,的變化標準： 請見該系列的放置壽命說明標準。 泄漏電流：低于初期規定值。 外觀：無異常。
4	TemperatureCycling 温度循环	JESD22Method JA-104	1000 cycles (-40°C to 105°C) Note: If 85°C or 125°C part the 1000 cycles will be at that temperature rating. Measurement at 24±4 hours after test conclusion. 30min maximum dwell time at each temperature extreme. 1 min. maximum transition time. 1000个循环（-40°C到105°C）。注意：如果85°C或125°C的产品，1000个循环应在其温度等级下进行。试验结束后24±4小时内进行测试。 每个温度的停留时间不超过30分钟，转换时间不超过1分钟。	Capacitance change : within ±20% of the initial specified value. Tan δ :200% of initial specified value .Leakage current : less than specified value . Appearance : no abnormal . 靜電容量變化： 最初規定值的±20%以內。 損失角：規定值2倍， 泄漏電流：低于規定值， 外觀：無異常。
7	Biased Humidity 高温高濕	MIL-STD-202 Method 103	1000 hours 85°C/85%RH. Rated Voltage. Measurement at 24±4 hours after test conclusion. 在温度85°C，湿度85%的条件下放置1000小时。 额定电压。试验结束后24±4小时内进行测试。	Capacitance change : within ±20% of the initial specified value. Tan δ :less than specified value .Leakage current : less than specified value .Appearance : no abnormal . 靜電容量變化： 最初規定值的±20%以內。 損失角：低于規定值， 泄漏電流：低于規定值， 外觀：無異常。

NO.	Stress 应力方式	Reference 参考方法	Additional Requirements 附加要求	SPECIFICATION 規格
8	Operational Life 工作寿命	MIL-STD-202 Method 108	<p>Note: 3000 hrs @ 105°C. If 85°C or 125°C part will be tested at that temperature. Rated Voltage applied. Measurement at 24±4 hours after test conclusion.</p> <p>注意：3000小时@ 105°C。如果85°C或125°C的产品，应在其温度下进行。施加额定的电压。试验结束后24±4小时内进行测试。</p>	<p>Capacitance change Tan δ .Rate of change: please have a look at this eries of load life standard. less than specified value . Appearance : no abnormal .</p> <p>容量.損失角,的變化標準： 請見該系列的負荷壽命說明標準 泄漏電流：低于初期規定值 . 外觀：無異常 .</p>
9	External Visual 外观	MIL-STD-883 Method 2009	<p>Inspect device construction, marking and workmanship. Electrical Test not required.</p> <p>检查器件结构，标识和工艺质量。不要求电气测试。</p>	<p>In the experimental report</p> <p>分布在試驗報告中</p>
10	Physical Dimension 尺寸	JESD22Method JB-100	<p>Verify physical dimensions to the applicable device detail specification. Note: User(s) and Suppliers spec. Electrical Test not required.</p> <p>按适用的器件规格验证物理尺寸。注意：用户和供应商规格。不要求电气测试。</p>	<p>Do judgement, according to the specification sheet.</p> <p>依據規格書判斷</p>
11	Terminal Strength (Leaded)端子强度 (引脚)	MIL-STD-202 Method 211	<p>Test leaded device lead integrity only. Conditions: A (454 g), C (227 g), E (1.45 kg-mm)</p> <p>只进行引脚器件的引脚牢固性测试。条件：A (454克)， C (227克)， E (1.45公斤-mm)。</p>	<p>Capacitance change : within ± 5% of the initial specified value. Tan δ :less than specified value. Leakage current : less than specified value .</p> <p>靜電容量變化： 最初規定值的±5%以內。 損失角：低于規定值 . 泄漏電流：低于規定值 .</p>

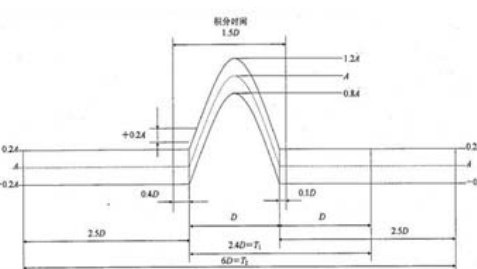
NO.	Stress 应力方式	Reference 参考方法	Additional Requirements 附加要求	SPECIFICATION 規格
12	Resistance to Solvents 溶剂抵抗	MIL-STD-202 Method 215	<p>Note: Also aqueous wash chemical - OKEM clean or equivalent. Do not use banned solvents.</p> <p>注意：水洗清洗剂-OKEM清洗剂或其它相同的溶剂。不要使用禁止的溶剂。</p>	<p>Capacitance change : within $\pm 5\%$ of the initial specified value. Tan δ :less than specified value .Leakage current : less than specified value ,Appearance : Print without loss, appearance without exception</p> <p>靜電容量變化：最初規定值的$\pm 5\%$以內。 損失角：低於規定值。 泄漏電流：低於規定值。 外觀：印刷字体无脱落及外观无异常</p>
13	Mechanical Shock 机械冲击	MIL-STD-202Method 213	<p>Figure 1 of Method 213. Condition C 方法213图表1，条件C。</p> 	<p>Capacitance change : within $\pm 5\%$ of the initial specified value. Tan δ :less than specified value .Leakage current : less than specified value .Appearance : no abnormal .</p> <p>靜電容量變化：最初規定值的$\pm 5\%$以內。 損失角：低於規定值， 泄漏電流：低於規定值。 外觀：無異常。</p>
14	Vibration 振动	MIL-STD-202Method 204	<p>5g's for 20 minutes 12 cycles each of 3 orientations. Note: Use 8"X5" PCB .031" thick with 7 secure points on one 8" side and 2 secure points on corners of opposite sides. Parts mounted within 2" from any secure point. Test from 10-2000 Hz.</p> <p>5G 20分钟，三个方向每个方向12个循环。 注意：使用8"X5" 印刷线路板，.031" 厚，在长的一边有7个固定点，在对面的边的角有2个固定点。产品在距离固定点2" 内安装。测试频率从10-2000赫兹。</p>	<p>Capacitance change : within $\pm 5\%$ of the initial specified value. Tan δ :less than specified value .Leakage current : less than specified value , No damage or leakage of electrolyte .</p> <p>靜電容量變化：最初規定值的$\pm 5\%$以內。 損失角：低於規定值。 泄漏電流：低於規定值， 無損傷或電解液漏出。</p>
15	Resistance to Soldering Heat 抗焊接热	MIL-STD-202 Method 210	<p>Condition B no pre-heat of samples. Note: Single Wave Solder. Procedure 1 with solder within 1.5mm of device body for Leaded and 0.75mm for SMD. SMD – remove carrier.</p> <p>条件B，样品不进行预热。注意：单一波峰焊。按程序1焊接，对于引脚器件浸入器件本体的1.5mm的深度，对于表面贴装元件为0.75mm。表面贴装元件-去除载体。</p>	<p>Capacitance change : within $\pm 10\%$ of the initial specified value. Tan δ :less than specified value .Leakage current : less than specified value .</p> <p>靜電容量變化：最初規定值的$\pm 10\%$以內。 損失角：低於規定值。 泄漏電流：低於規定值。</p>

NO.	Stress 应力方式	Reference 参考方法	Additional Requirements 附加要求	SPECIFICATION 規格
18	Solderability 可焊性	J-STD-002	<p>For both Leaded & SMD. Electrical Test not required. Magnification 50 X. Conditions: Leaded: Method A @ 235°C, category 3. SMD: a) Method B, 4 hrs @ 155°C dry heat @235°C b)Method B @ 215°C category 3 c)Method D category 3 @ 260°C.</p> <p>用于引脚和表面贴装元件，不需要电气测试。放大倍数50倍。测试条件： 引脚产品：方法A@235°C，类别3。 表面贴装元件：a) 方法B, 4 小时@155°C 干热@235°C b)方法B @215°C 类别3。 c)方法D 类别3 @260°C</p>	<p>The solder alloy shall cover the 95% or more of the dipped lead's area .</p> <p>錫液要覆蓋導針浸入表面積的95% 以上。</p>
19	Electrical Characterization 电气特性	User Spec.用户规格	<p>Parametrically test per lot and sample size requirements, summary to show Min, Max, Mean and Standard deviation at room as well as Min and Max operating temperatures.</p> <p>按批次和样品数量要求进行参数试验，总结出室温下及最低，最高工作温度下器件的最小值，最大值，平均值和标准偏差。</p>	<p>Capacitance change :within ± 20% of the initial measured value.Leakage current : less than specified value .</p> <p>靜電容量變化： 最初測定值的± 20%內.125°C 為規格值10倍以下，105°C 為規格值8倍以下，85°C 為規格值5倍以下， 損失角：低於規定值。</p>
27	Surge Voltage 浪涌电压	JIS-C-5101-1	<p>Rated surge voltage shall be applied (swich on) for 30 ± 5 seconds and then shall be applied (swich off) with discharge for 330± 5 seconds at room temperature . This cycle shall be repeated for 1000 cycles .Duration of one cycle is 6 ± 0.5 minutes .</p> <p>在常溫下施加（合上開關）額定涌浪電壓 30 ± 5 秒，然後停止施加（斷開開關）涌浪電壓並且放電 330 ± 5秒。這個循環要重复1000次。以 6 ± 0.5 分鐘為一個循環周期。</p>	<p>Capacitance change : within ± 15% of the initial specified value. Tan δ :less than specified value .Leakage current : less than specified value . Appearance : no abnormal .</p> <p>靜電容量變化： 最初規定值的 ± 15% 以內。 損失角：低於規定值。 洩漏電流：低於規定值。 外觀：無異常。</p>

鋁電解電容器存放環境與控制

Storage Conditions and Control for Aluminum Electrolytic Capacitor

1. 環境溫度：5°C ~ 35°C, 環境相對濕度：75%以下。

Store the capacitor at a temperature of 5°C to 35°C and at a relative humidity of less than 75% .

2. 存放環境不應有陽光直射, 不宜高溫。

Store the capacitor in low temperature places free from direct sun shine .

3. 存放環境不能有鹽分、油含量高的霧氣。

Store the capacitor in places free from oil vapor、salt water vapor.

4. 存放在遠離氯氣、氨氣、硫化氫、亞硫酸、硝酸等有害氣體含量高的地方。

Store the capacitor in places far from toxic gases (chlorine、ammonium、hydrogen sulfide、sulphurous acid、nitric acid , etc) .

5. 儲存環境不能有臭氧、紫外線或輻射。

Store the capacitor in place free from Ozone、ultraviolet ray or radiation .

Detergent needing attention:

使用清潔劑之注意事項:

Hydrogen carbide liquid and halogen liquid can cause Aluminium Electrolytic Capacitor to corrode. Some of Safe and Unsafe detergent are as follows;

鋁質電解電容器會受含有碳化氫鹵素容劑之侵蝕,下列為各種安全與不安全之清潔劑,為避免不必要的損失,您所使用有關印刷基板之清潔劑名請事先告知本公司.

Safe 安全	Unsafe 不安全
Methanol 甲醇	1.1.2- trichloroethane 1.1.2- 三氯乙烷
Ethanol 乙醇	Tetrachloroethylene 四氯化碳
Propanol 丙醇	Chloroform(colorless volatilizable liquid) 哥羅仿(無色揮發性液體)
Butanol 丁醇	Dichloromethane 二氯甲烷
Detergent 去垢劑	Trichlorethylene 三氯甲烯
	Dimethybenzene 二甲苯

Caution for Proper use of PET Sleeve in Electrolytic Capacitors

Caution: Avoid PET sleeve to contact water , Because the PET material will be dissolved by water at high temperature

1. PET sleeve water dissolved conditions

(1) When PET sleeve contact water it will not action.

During production process, The PET sleeve have water or water in case of Capacitor and capacitor in high temperature, The PET sleeve will dissolved.

(2) Avoid use list solvents to clean the PET sleeve capacitors.

1、 Aromatic Hydrocarbon(s)

Example: Solvent	Status
Benzene	To dissolved
Toluene	To dissolved
Xylene	To dissolved

2、 Low molecular Ketones & Esters

Example:

Methyl Ethyl Ketone(MEK)
Dimethyl Ketone(Acetone)
Methyl Isobutyl Ketone(MIBK)
Cyclohexanone
Ethyl Acetate(EA)

3、 Halogenated Hydrocarbon

Example:

Methylene Chloride (MC)
Trichloroethyle (TCE)

2. When PET sleeve or case of capacitor dirty with oil that will not dissolved, During production process when their temperature rise up to 80°C, The sleeve will shrink unsmooth.

ALUMINUM ELECTROLYTIC CAPACITORS

STRUCTURE and MATERIALS

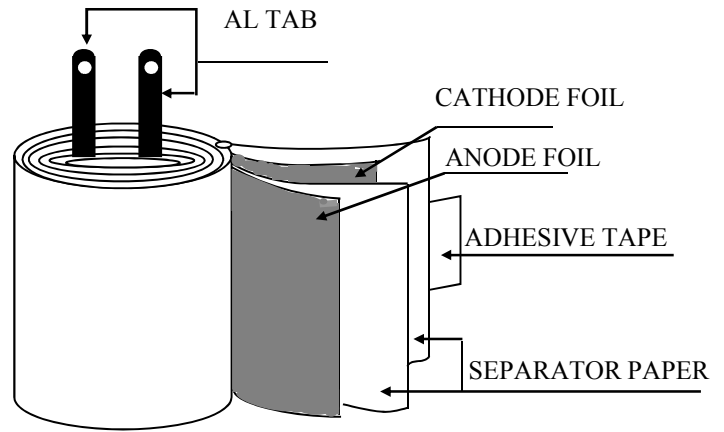
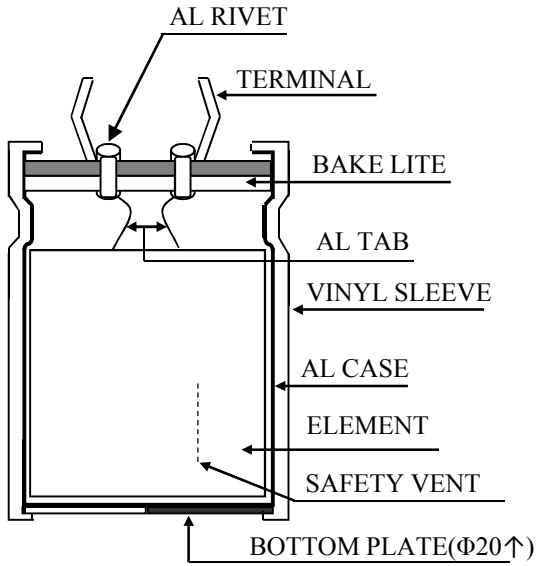

※.LARGE SIZED TYPE CAPACITORS COMPONENT

PART NAME	MATERIALS
AL RIVET	ALUMINUM 99.9%
TERMINAL	SPCC
BAKE LITE	RUBBER+PAPER LAMINATE
AL TAB	ALUMINUM 99.9% OVER
SLEEVE	INK
	P.E.T (Polyethylene Terephthalate Resin)
AL CASE	ALUMINUM 99.5%
ANODE FOIL	FORMED ALUMINUM 99.9% OVER
CATHODE FOIL	FORMED ALUMINUM 98.4% OVER
SEPARATOR PAPER	INSULATION PAPER
ADHESIVE TAPE	POLY PROPYLENE FILM

6. PRECAUTIONS AND GUIDELINES TO USERS

When using aluminum electrolytic capacitors, pay strict attention to the following:

1. Electrolytic capacitors for DC application require polarization.

Confirm the polarity. If used in reversed polarity, the circuit life may be shortened or the capacitor may be damaged. For use on circuits whose polarity is occasionally reversed, or whose polarity is unknown, use bi-polarized capacitors(BP-series). Also, note that the electrolytic capacitor cannot be used for AC application.

2. Do not apply a voltage exceeding the capacitor's voltage rating.

If a voltage exceeding the capacitor's voltage rating is applied, the capacitor may be damaged as leakage current increases. When using the capacitor with AC voltage superimposed on DC voltage, care must be exercised that the peak value of AC voltage does not exceed the rated voltage.

3. Do not allow excessive ripple current to pass.

Use the electrolytic capacitor at current values within the permissible ripple range. If the ripple current exceeds the specified value, request capacitors for high ripple current applications.

4. Ascertain the operating temperature range.

Use the electrolytic capacitors according to the specified operating temperature range. Usage at room temperature will ensure longer life.

5. The electrolytic capacitor is not suitable for circuits in which charge and discharge are frequently repeated.

If used in circuits in which charge and discharge are frequently repeated, the capacitance value may drop, or the capacitor may be damaged. Please consult our engineering department for assistance in these applications.

If the electrolytic capacitor is allowed to stand for a long time, its withstand voltage is liable to drop, resulting in increased leakage current. If the rated voltage is applied to such a product, a large leakage current occurs and this generates internal heat, which damaged the capacitor. If the electrolytic capacitor is allowed to stand for a long time, therefore, use it after giving voltage treatment.(However,the electrolytic capacitors can be guarantee for 2 years if keep in the normal temperature.)

6. Be careful of temperature and time when soldering.

When soldering a printed circuit board with various components, care must be taken that the soldering temperature is not too high and that the dipping time is not too long. Other wise, there will be adverse effects on the electrical characteristics and insulation sleeve of electrolytic capacitors in the case of small-sized electrolytic capacitors, nothing abnormal will occur if dipping is performed at less than 260 °C for less than 10 seconds.

7. Do not place a soldering iron body of the capacitor.

The electrolytic capacitor is covered with a vinyl sleeve. If the soldering iron comes in contact with the electrolytic capacitor body during wiring, damage to the vinyl sleeve and/or case may result in defective insulation, or improper protection

8. Cleaning circuit boards after soldering.

Some solvents have adverse effects on capacitors.
Please refer to the next page.

9. Do not apply excessive force to the lead wires or terminals.

If excessive force is applied to the lead wires and terminals, they may be broken or their connections with the internal elements may be affected. (For strength of terminals, refer to JIS C5101-1, JIS C5101-4)

10. Care should be used in selecting a storage area.

If electrolytic capacitors are exposed to high temperatures caused by such things as direct sunlight, the life of the capacitor may be adversely affected. Storage in a high humidity atmosphere may affect the solderability of lead wires and terminals.

11. Surge voltage:

Rated surge voltage shall be applied for 30 seconds and then shall be applied with discharge,for 330 seconds at room temperature .This cycle shall be repeated for 1000 cycles;Duration of one cycle is 6 minutes ;then to judge capacitor's characteristics and appearance.

Rated Voltage(WV)	4	6.3	8	10	16	25	35	50	63	80	100	160	200	250	350	400	420	450	500
Surge Voltage(SV)	5	8	10	13	20	32	44	63	79	100	125	200	250	300	400	450	470	500	550

For methods of testing, refer to JIS C 5101-1, JIS C 5101-4.

※ The above mentioned material according to EIAJRCR-2367B (issued in March, 2002), titled "Guideline of notabilia for aluminum electrolytic capacitors for use in electronic equipment". Please refer to the book for details.

ALUMINUM ELECTROLYTIC CAPACITORS

(尖角型包裝圖) Packing drawing of Snap-In Type

1) BOX

單位Unit :mm



說明：為了抑制再生電壓產生,包裝時在電容引腳上方放整塊鋁箔,用於短接放電,并在放電紙上放整塊紙板固定,使用前請將整小箱倒置15秒,使電容器正負引腳充分插入鋁箔進行放電。

Description: To avoid the generation of recurring voltage, we will put a piece of aluminum foil above the leadwire during packaging, and capacitors can discharge within a short time, and put a cardboard to fix Al. foil. please invert the box for 15 seconds before using, and the anode/cathode leadwire are fully inserted into the aluminum foil for discharge.

(INNER BOX)

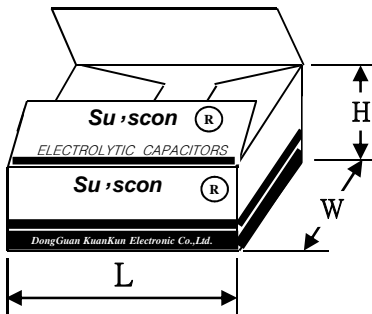

(OUT BOX)

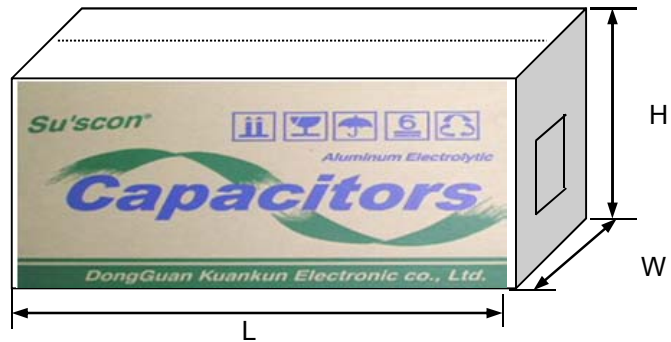

內箱尺寸Size of Inner box :
(L)204x(W)204x(H)146

外箱尺寸Size of Inner box :
(L)428x(W)214x(H)312

2)明細表Details

尺寸 Size (Φ×L)	每內箱擺放標準 the placing standards of inner box	每外箱數量 quality in outer box (四個內箱為一個外箱) (4 inner boxes form an outer box) (KPCS/箱box)
35×45	25pcs×2 layer	0.2