

A

A
view without cover

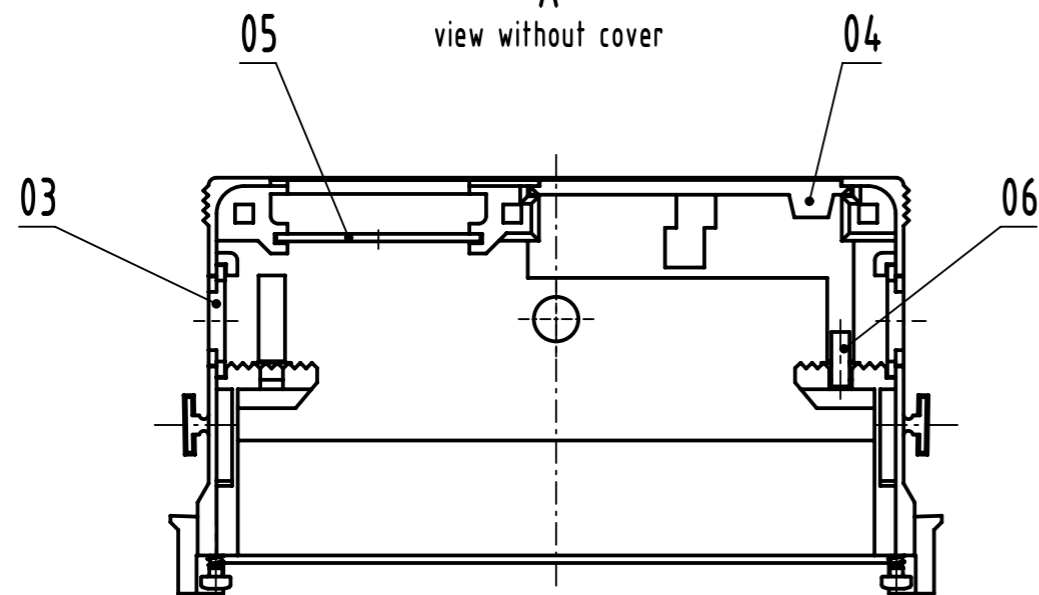

1 tightening torque for cover screws: 35±5 Ncm

content shell housing			spare parts
pos.	number	description	part no.
01	1	shell	
02	1	cover	
03	2	blinding piece	09 02 000 9905
04	1	blinding plate	
05	1	grounding plate	
06	1	cable tie	
07	2	self-tapping screw M2.2x8-T6	09 06 001 9979
08	3	tapping screw ISO 1483-ST2.9x13-F	

	All Dimensions in mm Original Size DIN A3		Scale 1:1	Free size tol.	Ref. Sub.	
	All rights reserved Department EL PD		Created by 00103855	Inspected by STORCK	Standardisation SAP_WFRT	Date 2022-02-15
HARTING D-32339 Espelkamp		Title DIN Power shell housing C 20mm for type E + har-bus 64			Doc-Key / ECM-Nr. 100141651/UGD/003/C 500000211446	
		Type TB	Number 09050480501		Rev. C	Page 1/1