



Through Hole Lamp
Product Data Sheet
LTL2P3TGZ2KS-032A

Spec No. :DS20-2013-0138
Effective Date: 07/10/2019
Revision: A

LITE-ON DCC

RELEASE

BNS-OD-FC001/A4

Through Hole Lamp
LTL2P3TGZ2KS-032A

Through Hole Lamp

LTL2P3TGZ2KS-032A

<u>Rev</u>	<u>Description</u>	<u>By</u>	<u>Date</u>
Ver. A	Adjust IV & Vf spec	Henry	11/03/2017
Above data for PD and Customer tracking only			
-	Upload to OPNC	NEDPHAKAS	07/04/2013
Ver. A	Update to OPNC	Apisit	11/27/2018

Through Hole Lamp LTL2P3TGZ2KS-032A

1. Description

5mm round lamp is a popular design with a smooth uniform view angle radiation pattern suitable in Full color signboard, Billboard sign, Message sign and bus sign. High luminous intensity output has a higher emitting efficiency to save power energy. Advanced epoxy technology has a good moisture resistance and UV protection to be used in package, and it can reduce the effect of long term exposure in outdoor environment.

1.1. Features

- High Luminous intensity output.
- Low power consumption & High efficiency.
- Superior resistance to moisture
- Good UV inhibitor
- Lead free & RoHS Compliant
- Popular T-1 $\frac{3}{4}$ diameter, Green InGaN 530nm Lamp, Water clear package.
- Typical viewing angle 23°

1.2. Applications

- Video message sign
- Traffic sign
- Message sign

2. Outline Dimensions

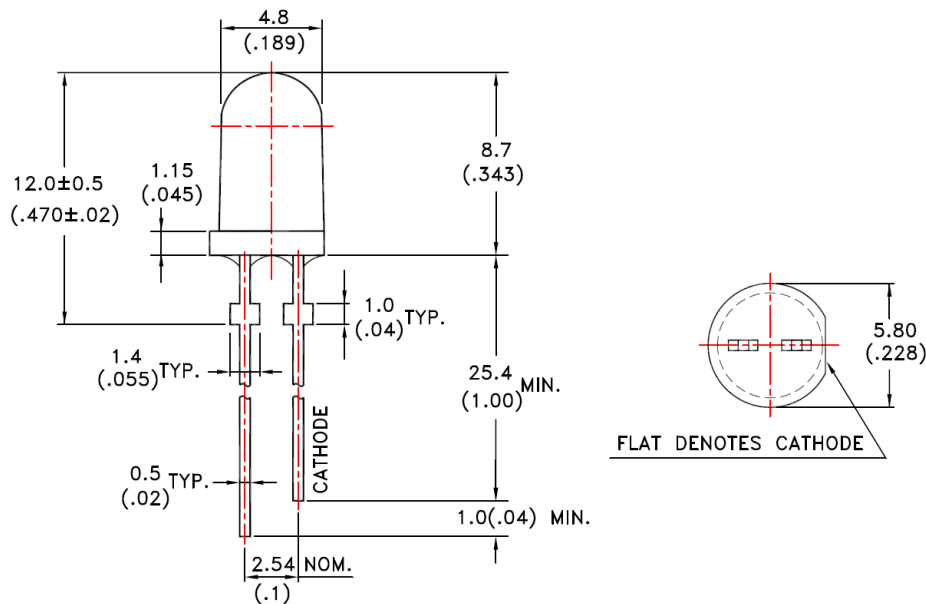

Notes :

1. All dimensions are in millimeters (inches).
2. Tolerance is ± 0.25 mm (.010") unless otherwise noted.
3. Protruded resin under flange is 1.0mm (.04") max.
4. Lead spacing is measured where the leads emerge from the package.
5. Specifications are subject to change without notice.

Through Hole Lamp LTL2P3TGZ2KS-032A

3. Absolute Maximum Ratings at TA=25°C

Parameter	Maximum Rating	Unit
Power Dissipation	105	mW
Peak Forward Current (Duty Cycle \leq 1/10, Pulse Width \leq 10ms)	100	mA
DC Forward Current	30	mA
Derating Linear From 40°C	0.45	mA/°C
Reverse Voltage	5	V
Operating Temperature Range	-40°C to + 85°C	
Storage Temperature Range	-40°C to + 100°C	
Lead Soldering Temperature [2.0mm (.079") From Body]	260°C for 5 Seconds Max.	

4. Electrical / Optical Characteristics at TA=25°C

Parameter	Symbol	Min.	Typ.	Max.	Unit	Test Condition
Luminous Intensity	Iv	19000		32000	mcd	IF = 20mA Note 1,5
Viewing Angle	$\theta_{1/2}$		23		deg	Note 2 (Fig.6)
Peak Emission Wavelength	λ_P		531		nm	Measurement @Peak (Fig.1)
Dominant Wavelength	λ_d	520		530	nm	Note 4
Spectral Line Half-Width	$\Delta\lambda$		35		nm	
Forward Voltage	VF	2.6		3.5	V	IF = 20mA
Reverse Current	IR			50	μ A	VR = 5V

NOTE:

- Luminous intensity is measured with a light sensor and filter combination that approximates the CIE eye-response curve.
- $\theta_{1/2}$ is the off-axis angle at which the luminous intensity is half the axial luminous intensity.
- Iv classification code is marked on each packing bag.
- The dominant wavelength, λ_d is derived from the CIE chromaticity diagram and represents the single wavelength which defines the color of the device.
- Iv guarantee must be included with $\pm 15\%$ testing tolerance.
- Reverse voltage (VR) condition is applied for IR test only. The device is not designed for reverse operation.

Through Hole Lamp LTL2P3TGZ2KS-032A

5. Typical Electrical / Optical Characteristics Curves

(25°C Ambient Temperature Unless Otherwise Noted)

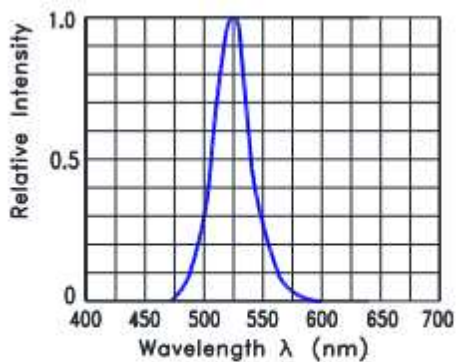

Fig.1 Relative Intensity VS. Wavelength

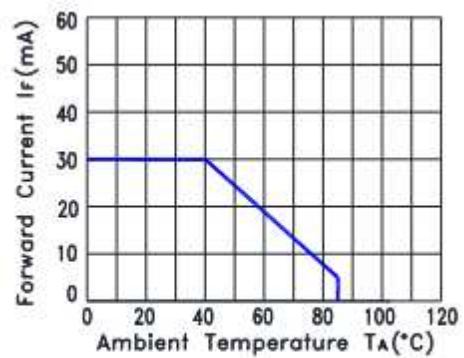

Fig.2 Forward Current Derating Curve

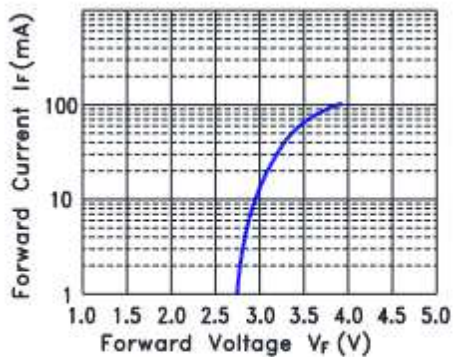

Fig.3 Forward Current vs. Forward Voltage

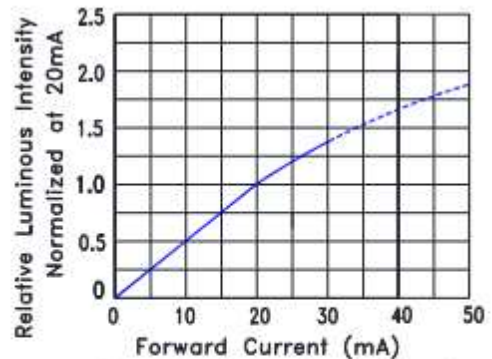

Fig.4 Relative Luminous Intensity vs. Forward Current

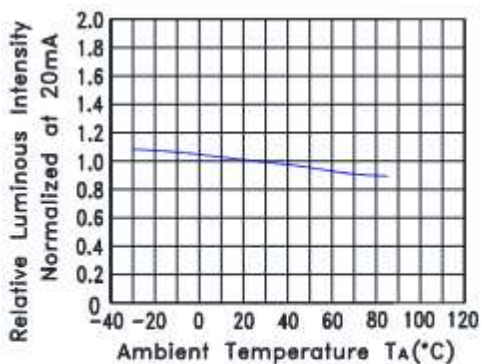

Fig.5 Relative Luminous Intensity VS. Ambient Temperature

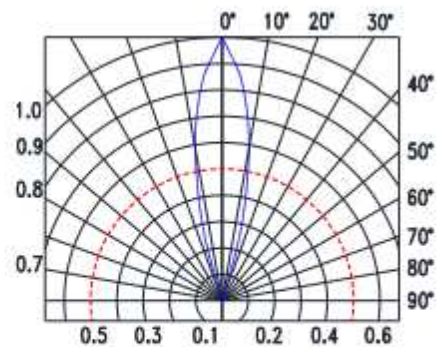

Fig.6 Spatial Distribution

Through Hole Lamp LTL2P3TGZ2KS-032A

6. Taping Features

- * Compatible with radial lead automatic insertion equipment.
- * Most radial lead plastic lead lamps available packaged in tape and folding.
- * 2.54mm (0.1") straight lead spacing available.
- * Folding packaging simplifies handling and testing.
- * Reel packaging is available by removing suffix "A" on option.

Package Dimensions

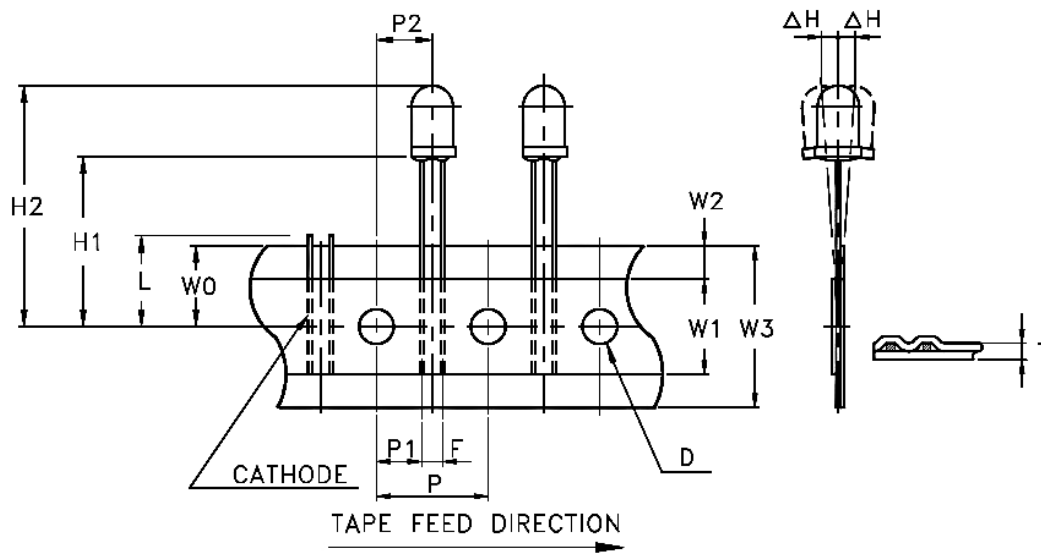

Item	Symbol	Specification			
		Minimum		Maximum	
		mm	inch	mm	inch
Tape Feed Hole Diameter	D	3.8	0.149	4.2	0.165
Component Lead Pitch	F	2.3	0.091	3.0	0.118
Front to Rear Deflection	ΔH	--	--	2.0	0.078
Feed Hole to Bottom of Component	H1	20.0	0.787	21.0	0.827
Feed Hole to Overall Component Height	H2	28.4	1.118	30.0	1.181
Lead Length After Component Height	L	W0		11.0	0.433
Feed Hole Pitch	P	12.4	0.488	13.0	0.511
Lead Location	P1	4.4	0.173	5.8	0.228
Center of Component Location	P2	5.05	0.198	7.65	0.301
Total Tape Thickness	T	--	--	0.90	0.035
Feed Hole Location	W0	8.5	0.334	9.75	0.384
Adhesive Tape Position	W2	0	0	3.0	0.118
Tape Width	W3	17.5	0.689	19.0	0.748

Through Hole Lamp
LTL2P3TGZ2KS-032A

7. Packing Spec.

Total 2,000 pcs per inner carton

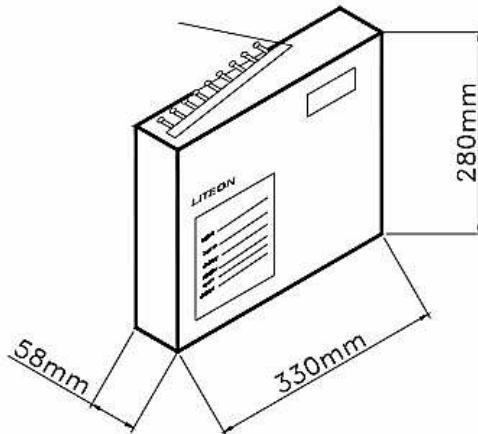

Tolerance: $\pm 5\text{mm}$

10 Inner cartons per outer carton

Total 20,000 pcs per outer carton

In every shipping lot, only the last pack will be non-full packing

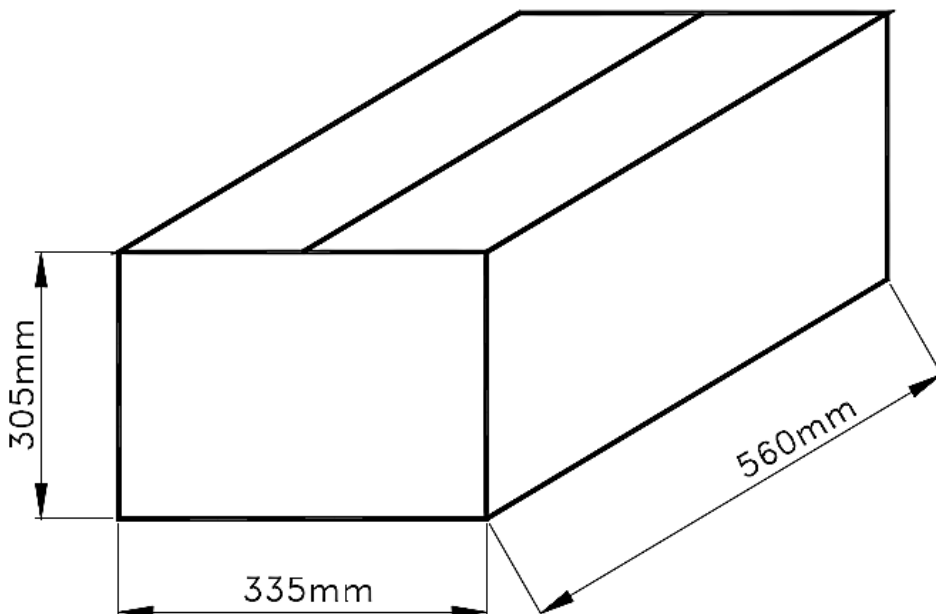

**Through Hole Lamp
LTL2P3TGZ2KS-032A**

8. Bin Table Specification

Luminous Intensity Iv (mcd) IF@20mA		
Bin Code	Min.	Max.
2	19000	24000
3	24000	32000

Note: Tolerance of each bin limit is $\pm 15\%$

Dominant Wavelength Unit : nm @20mA		
Bin Code	Min	Max
G1	520	525
G2	525	530

Note: Tolerance of each bin limit is $\pm 1\text{nm}$

Forward Voltage Vf Unit : V @20mA		
Bin Code	Min	Max
1	2.6	2.8
2	2.8	3.0
3	3.0	3.2
4	3.2	3.4
5	3.4	3.5

Note: Tolerance of each bin limit is $\pm 0.1\text{V}$

Through Hole Lamp LTL2P3TGZ2KS-032A

9. CAUTIONS

9.1. Application

This LED lamp is good for application of indoor and outdoor sign, also ordinary electronic equipment.

9.2. Storage

The storage ambient for the LEDs should not exceed 30°C temperature or 70% relative humidity. It is recommended that LEDs out of their original packaging are used within three months. For extended storage out of their original packaging, it is recommended that the LEDs be stored in a sealed container with appropriate desiccant or in desiccators with nitrogen ambient.

9.3. Cleaning

Use alcohol-based cleaning solvents such as isopropyl alcohol to clean the LEDs if necessary.

9.4. Lead Forming & Assembly

During lead forming, the leads should be bent at a point at least 3mm from the base of LED lens. Do not use the base of the lead frame as a fulcrum during forming. Lead forming must be done before soldering, at normal temperature. During assembly on PCB, use minimum clinch force possible to avoid excessive mechanical stress.

9.5. Soldering

When soldering, leave a minimum of 3mm clearance from the base of the lens to the soldering point. Dipping the lens into the solder must be avoided. Do not apply any external stress to the lead frame during soldering while the LED is at high temperature.

Recommended soldering conditions:

Soldering iron		Wave soldering	
Temperature	350°C Max.	Pre-heat	100°C Max.
Soldering time	3 seconds Max. (one time only)	Pre-heat time	60 seconds Max.
Position	No closer than 2mm from the base of the epoxy bulb	Solder wave	260°C Max.
		Soldering time	5 seconds Max.
		Dipping Position	No lower than 2mm from the base of the epoxy bulb

Note: Excessive soldering temperature and/or time might result in deformation of the LED lens or catastrophic failure of the LED. IR reflow is not suitable process for through hole LED lamp product.

9.6. Drive Method

An LED is a current-operated device. In order to ensure intensity uniformity on multiple LEDs connected in parallel in an application, it is recommended that a current limiting resistor be incorporated in the drive circuit, in series with each LED as shown in Circuit A below.

Circuit model (A)

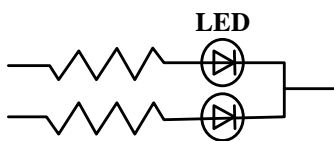

(A) Recommended circuit

Circuit model (B)

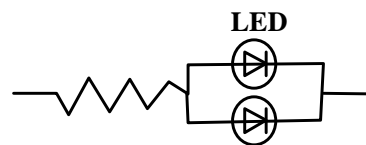

(B) The brightness of each LED might appear different due to the differences in the I-V characteristics of those LEDs.

Through Hole Lamp LTL2P3TGZ2KS-032A

9.7. ESD (Electrostatic Discharge)

Static Electricity or power surge will damage the LED.

Suggestions to prevent ESD damage:

- Use a conductive wrist band or anti- electrostatic glove when handling these LEDs
- All devices, equipment, and machinery must be properly grounded
- Work tables, storage racks, etc. should be properly grounded
- Use ion blower to neutralize the static charge which might have built up on surface of the LEDs plastic lens as a result of friction between LEDs during storage and handing

Suggested checking list:

Training and Certification

- 9.7.1.1. Everyone working in a static-safe area is ESD-certified?
- 9.7.1.2. Training records kept and re-certification dates monitored?

Static-Safe Workstation & Work Areas

- 9.7.2.1. Static-safe workstation or work-areas have ESD signs?
- 9.7.2.2. All surfaces and objects at all static-safe workstation and within 1 ft measure less than 100V?
- 9.7.2.3. All ionizer activated, positioned towards the units?
- 9.7.2.4. Each work surface mats grounding is good?

Personnel Grounding

- 9.7.3.1. Every person (including visitors) handling ESD sensitive (ESDS) items wear wrist strap, heel strap or conductive shoes with conductive flooring?
- 9.7.3.1. If conductive footwear used, conductive flooring also present where operator stand or walk?
- 9.7.3.2. Garments, hairs or anything closer than 1 ft to ESD items measure less than 100V*?
- 9.7.3.3. Every wrist strap or heel strap/conductive shoes checked daily and result recorded for all DLs?
- 9.7.3.4. All wrist strap or heel strap checkers calibration up to date?

Note: *50V for Blue LED.

Device Handling

- 9.7.4.1. Every ESDS items identified by EIA-471 labels on item or packaging?
- 9.7.4.2. All ESDS items completely inside properly closed static-shielding containers when not at static-safe workstation?
- 9.7.4.3. No static charge generators (e.g. plastics) inside shielding containers with ESDS items?
- 9.7.4.4. All flexible conductive and dissipative package materials inspected before reuse or recycle?

Others

- 9.7.5.1. Audit result reported to entity ESD control coordinator?
- 9.7.5.2. Corrective action from previous audits completed?
- 9.7.5.3. Are audit records complete and on file?

Through Hole Lamp LTL2P3TGZ2KS-032A

10. Reliability Test

Classification	Test Item	Test Condition	Sample Size	Reference Standard
Endurance Test	Operation Life	Ta = under room temperature IF = per datasheet maximum drive current Test Time= 1000hrs	45 PCS (CL=90%; LTPD=5%)	MIL-STD-750D:1026 (1995) MIL-STD-883G:1005 (2006)
	High Temperature High Humidity storage (THB)	Ta = 85°C RH = 85% Test Time= 500hrs	45 PCS (CL=90%; LTPD=5%)	MIL-STD-202G:103B (2002) JEITA ED-4701:100 103 (2001)
	Steady state Operation Life of High Humidity Heat	Ta = 85°C, RH= 85 % IF = as per datasheet maximum rating Test Time= 500hrs	76 PCS (CL=90%; LTPD=3%)	JESD22-A101C (2009)
	Low Temperature Operation Life of	Ta = -30°C IF = per datasheet typical drive current Test Time= 1000hrs	45 PCS (CL=90%; LTPD=5%)	
	High Temperature Storage	Ta= 105 ± 5°C Test Time= 1000hrs	45 PCS (CL=90%; LTPD=5%)	MIL-STD-750D:1031 (1995) MIL-STD-883G:1008 (2006) JEITA ED-4701:200 201 (2001)
	Low Temperature Storage	Ta= -55 ± 5°C Test Time= 1000hrs	45 PCS (CL=90%; LTPD=5%)	JEITA ED-4701:200 202 (2001)
Environmental Test	Temperature Cycling I	100°C ~ 25°C ~ -40°C ~ 25°C 30mins 5mins 30mins 5mins Test time: 200 Cycles	76 PCS (CL=90%; LTPD=3%)	MIL-STD-750D:1051 (1995) MIL-STD-883G:1010 (2006) JEITA ED-4701:100 105 (2001) JESD22-A104C (2005)
	Temperature Cycling II	100 ± 5°C ~ -30°C ± 5°C 15mins 15mins Test time: 200 Cycles	76 PCS (CL=90%; LTPD=3%)	MIL-STD-750D:1056 (1995) MIL-STD-883G:1011 (2006) MIL-STD-202G:107G (2002) JESD22-A106B (2004)
	Solder Resistance	T.sol = 260 ± 5°C Dwell Time= 10±1 seconds 2mm from the base of the epoxy bulb	11 PCS (CL=90%; LTPD=18.9%)	MIL-STD-750D:2031(1995) JEITA ED-4701: 300 302 (2001)
	Solderability	T. sol = 245 ± 5°C Dwell Time= 5 ± 0.5 seconds (Lead Free Solder, Coverage ≥ 95% of the dipped surface)	11 PCS (CL=90%; LTPD=18.9%)	MIL-STD-750D:2026 (1995) MIL-STD-883G:2003 (2006) MIL-STD-202G:208H (2002) IPC/EIA J-STD-002 (2004)
	Soldering Iron	T. sol = 350 ± 5°C Dwell Time= 3.5 ± 0.5 seconds	11 PCS (CL=90%; LTPD=18.9%)	MIL-STD-202G:208H (2002) JEITA ED-4701:300 302 (2001)

11. Others

Through Hole Lamp
LTL2P3TGZ2KS-032A

The appearance and specifications of the product may be modified for improvement, without prior notice.

