

Current Transducer CDSR 0.07-TPDT

For the electronic detection of residual currents: DC, AC, pulsed..., with galvanic separation between the primary and the secondary circuit.

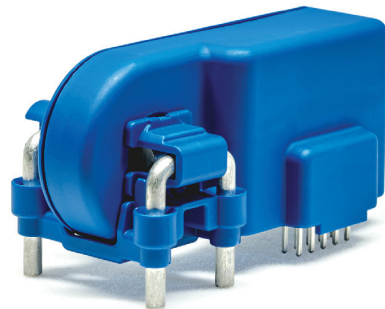

Features

- AC and DC Trigger outputs
- Single supply voltage 3.3 V
- PCB mounting
- Embedded primary jumpers.

Advantages

- High accuracy
- High overload capability
- High insulation capability
- Test winding.

Applications

- Leakage current measurement in an IC-CPD in-cable (mode 2) and for wall boxes (mode 3) contact and protection device
- Single phase nominal current up to ± 32 A RMS per primary conductor.

Complies with applications using these standards

- IEC 61851-1: 2017
- IEC 62752: 2016 (compliance for AC and DC currents)
- IEC 62955: 2018 (compliance for DC currents only).

Application Domain

- Residential.

Safety



Caution

If the device is used in a way that is not specified by the manufacturer, the protection provided by the device may be compromised. Always inspect the electronics unit and connecting cable before using this product and do not use it if damaged. Mounting assembly shall guarantee the maximum primary busbar temperature, fulfill clearance and creepage distance, minimize electric and magnetic coupling, and unless otherwise specified can be mounted in any orientation. The plastic housing is conform to IK06 level (1 Joule). The device was certified for indoor use only and at an altitude below 2000 m.



Caution, risk of electrical shock

This transducer must be used in limited-energy secondary circuits SELV according to IEC 61010-1, in electric/electronic equipment with respect to applicable standards and safety requirements in accordance with the manufacturer's operating specifications.

When operating the transducer, certain parts of the module can carry hazardous voltage (e.g. primary busbar, power supply).

De-energize all circuits and hazardous live parts before installing the product.

All installations, maintenance, servicing operations and use must be carried out by trained and qualified personnel practicing applicable safety precautions.

If the transducer is used in a manner not specified by the manufacturer, the protection provided by the equipment may be impaired.

Ignoring this warning can lead to injury and/or cause serious damage.

This transducer is a build-in device, whose hazardous live parts must be inaccessible after installation.

This transducer must be mounted in a suitable end-enclosure and its measuring jumpers must be at some point in the final installation protected behind a properly dimensioned circuit breaker that can be easily accessed by the end user of the application. Use caution during installation and use of this product; high voltages and currents may be present in circuit under test.

Main supply must be able to be disconnected.

Never connect the output to any equipment with a common mode voltage to earth greater than 30 volts.

Always wear protective clothing and gloves if hazardous live parts are present in the installation where the measurement is carried out.

This transducer is a built-in device, not intended to be cleaned with any product. Nevertheless if the user must implement cleaning or washing process, validation of the cleaning program has to be done by himself.



ESD susceptibility

The product is susceptible to be damaged from an ESD event and the personnel should be grounded when handling it.

Do not dispose of this product as unsorted municipal waste. Contact a qualified recycler for disposal.

Although LEM applies utmost care to facilitate compliance of end products with applicable regulations during LEM product design, use of this part may need additional measures on the application side for compliance with regulations regarding EMC and protection against electric shock. Therefore LEM cannot be held liable for any potential hazards, damages, injuries or loss of life resulting from the use of this product.



Underwriters Laboratory Inc. recognized component



"This Arrow indicates the positive residual current measurement"

Absolute maximum ratings

Parameter	Symbol	Unit	Value
Maximum supply voltage	$\pm U_{C \max}$	V	3.6
Maximum primary conductor temperature	$T_{B \max}$	°C	100
Guaranteed let-through energy per primary jumper		A ² s	80000
Electrostatic discharge voltage (HBM - Human Body Model)	$U_{ESD \text{ HBM}}$	kV	2

Absolute maximum ratings apply at 25 °C unless otherwise noted.
 Stresses above these ratings may cause permanent damage.
 Exposure to absolute maximum ratings for extended periods may degrade reliability.

UL 508: Ratings and assumptions of certification

Ongoing submission

Standards

- CSA C22.2 NO. 14-10 INDUSTRIAL CONTROL EQUIPMENT - Date 2011/08/01
- UL 508 STANDARD FOR INDUSTRIAL CONTROL EQUIPMENT - Date 2013
- UL 61010

Ratings

Parameter	Symbol	Unit	Value
Primary involved potential (RMS)		V	300
Maximum surrounding air temperature	T_A	°C	85
Primary current	I_P	A	32
Secondary supply voltage	U_C	V DC	3.3
Maximum output voltage	U_{out}	V	3.3

Conditions of acceptability

When installed in the end-use equipment, consideration shall be given to the following:

- 1 - *These devices must be mounted in a suitable end-use enclosure.*
- 2 - *The terminals have not been evaluated for field wiring.*
- 3 - *The CDSR xx-TPDT Series shall be used in a pollution degree 2 environment or better.*
- 4 - *Low voltage circuits are intended to be powered by a circuit derived from an isolating source (such as a transformer, optical isolator, limiting impedance or electro-mechanical relay) and having no direct connection back to the primary circuit (other than through the grounding means). The maximum current supplied to the device must be protected/limited to a maximum of 5 Amperes.*
- 5 - *These devices are intended to be mounted on the printed wiring board of the end-use equipment (with a minimum CTI of 100).*
- 6 - *CDSR xx-TPDT Series: based on results of temperature tests, in the end-use application, a maximum of 100°C cannot be exceeded on the primary jumper.*
- 7 - *During the "Startup time" period no residual current must be flowing through the transducer as a critical measurement zeroing is being performed.*

Marking

Only those products bearing the UL or UR Mark should be considered to be Listed or Recognized and covered under UL's Follow-Up Service. Always look for the Mark on the product.

Performances

All described performances are valid for the whole temperature range at $U_C = 3.3$ V, unless otherwise noted.

Insulation coordination

Parameter	Symbol	Unit	≤ Value	Comment
RMS voltage for AC insulation test, 50 Hz, 1 min	U_d	kV	4	
Impulse withstand voltage 1.2/50 μ s	U_{Ni}	kV	6	
Partial discharge RMS test voltage ($q_m < 10$ pC)	U_t	V	825	
Clearance (pri. - sec.)	d_{Ci}	mm	12.2	Shortest distance through air
Creepage distance (pri. - sec.)	d_{Cp}	mm	12.2	Shortest path along device body
Clearance (pri. - pri.)	d_{Ci}	mm	5.64	Shortest distance through air
Creepage distance (pri. - pri.)	d_{Cp}	mm	5.64	Shortest path along device body
Case material	-	-	V0	According to UL 94
Comparative tracking index	CTI		600	
Application example RMS voltage line-to-neutral		V	300	Reinforced insulation according to IEC 60664-1 or IEC 61010-1 CAT III, PD2

Environmental and mechanical characteristics

Parameter	Symbol	Unit	Min	Typ	Max	Comment
Ambient operating temperature	T_A	°C	-40		85	
Ambient storage temperature	$T_{A\,st}$	°C	-50		85	
Relative humidity	RH	%			85	
Mass	m	g		19		

General electrical data

Parameter	Symbol	Unit	Min	Typ	Max	Comment
Supply voltage $\bar{=}$	U_C	V	3.26	3.3	3.33	
Current consumption $\bar{=}$	I_C	mA			50	
Tripping threshold for DC residual currents	$I_{R\ Th\ DC}$	mA DC	4		6	
RMS tripping threshold for AC residual currents	$I_{R\ Th\ AC}$	mA RMS	23		30	DC to 1 kHz

Digital signals electrical parameters

Parameter	Symbol	Unit	Min	Typ	Max	Comment
Input logic low	$U_{in\ L}$	V	-0.3		0.8	
Input logic high	$U_{in\ H}$	V	2		$U_C + 0.2$	
Output logic low	$U_{out\ L}$	V			0.4	
Output logic high	$U_{out\ H}$	V	$U_C - 0.4$			
Sink / drive output maximum current	$I_{out\ max}$	mA	-4		4	

General switching parameters

Parameter	Symbol	Unit	Min	Typ	Max	Comment
Start-up time	t_{start}	ms			400	Also valid after a reset pulse. During this time no residual current must be flowing through the transducer as a self zeroing is being performed.
Minimum reset time	$t_{res\ min}$	μs	5			
Frequency of fault output	$f_{out\ fault}$	kHz	4		7	
Fault signal threshold	I_{Th}	mA	152		175	Fault output will stop oscillating and keep a constant logic level above this threshold.
Fault signal reaction time	t_{fault}	μs			200	

Typical mounting and interfacing

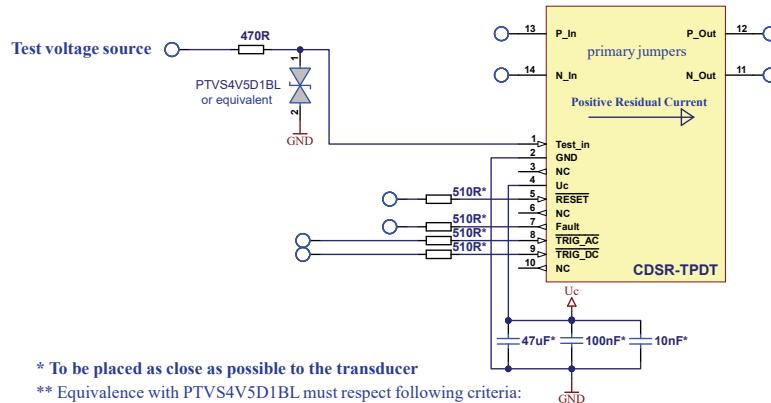

* To be placed as close as possible to the transducer
 ** Equivalence with PTVS4V5D1BL must respect following criteria:
 -Robustness against IEC 61000-4-5 8/20 μ s current waveform.
 -Maximum clamping voltage < 20V under 8/20us waveform test.
 -Breakdown voltage / Reverse standoff voltage > 4V.
 -Bidirectional protection.
Unused pins must be left unconnected.
 /RESET pin has internal 10kOhm pull-up and 22nF to ground connections.

Figure 1: typical mounting and interfacing

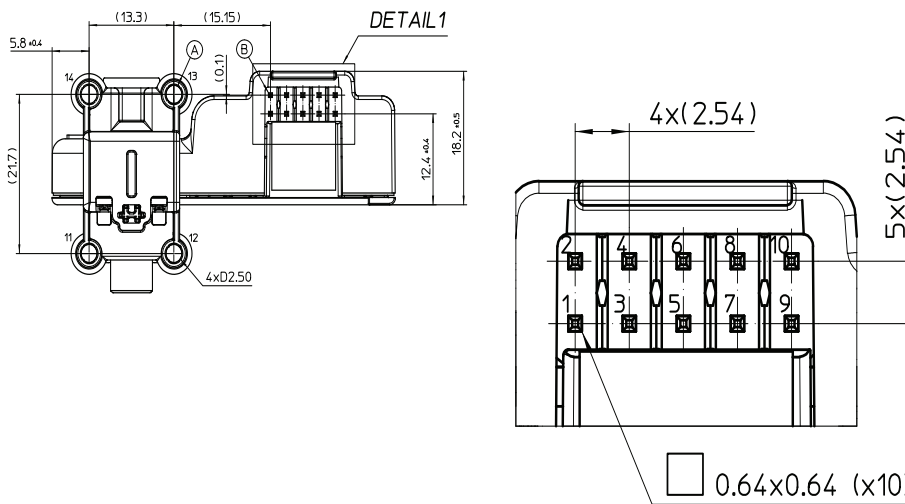

Pin N°	Function
1	Test_in
2	GND
3	NC
4	U_c
5	Reset
6	NC
7	Fault
8	TRIG_AC
9	TRIG_DC
10	NC

* Pin description:

- Pin N° 1 'Test_in': This pin is connected to a 10-turns test coil. It enables users to check periodically the performances of the transducer by injecting a known current. The other terminal of the coil is connected to ground.
- Pin N° 2 'GND': Power supply ground.
- Pin N° 3: NC
- Pin N° 4 ' U_c ': Power supply.
- Pin N° 5 'Reset': Active low-level reset signal. After reset release, a Power-On Reset procedure is executed by the transducer controller and non-volatile configuration files are charged up again.
- Pin N° 6: NC
- Pin N° 7 'Fault': Dynamic diagnostic signal. When no internal failure of the transducer or when the current to be measured is in the measuring range the signal present on this pin is a square wave with bounded frequency (please refer to the parameter "frequency of fault output"). This signal becomes static in case of transducer failure or in case of exceeded current range.
- Pin N° 8 'TRIG_AC': Active low-level trigger output
- Pin N° 9 'TRIG_DC': Active low-level trigger output
- Pin N° 10: NC

Fault-pin Signal

Dynamic diagnostic signal: when a fault is detected the signal remains in any steady state (can be a logic low (0) or high (1)).

Detected faults:

- Over-current
- Critical over-current
- Internal hardware self-test

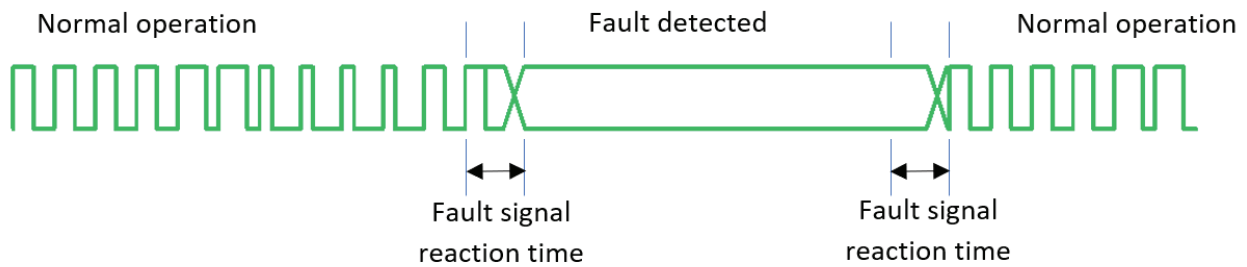

Figure 2: Fault-pin signal illustration

“Test-in” pin

The “Test in” pin is connected to a 10 turns coil inside the transducer: 1 mA injected to this pin will result in 10 mA measurement. This enables users to test the transducer.

Due to transformer effect a high impedance source is required to generate the test current.

Below an example of a 3.3 mA current generation in the test coil.

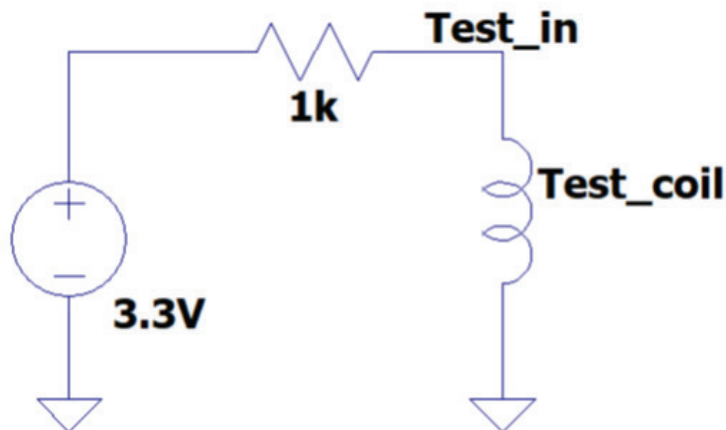

It is also required to connect a bidirectional protection device in order to protect the user PCBA against hazardous transient high pulse current through the primary jumper.

Standard Transient Voltage suppressor could accomplish this function (voltage rating to be defined based on specific user application but has to be > 4 V not to perturbate the transducer proper functioning).

See CDSR typical mounting and interfacing on [page 6](#).

“TRIG_xC” pins:

Both “TRIG_AC” and “TRIG_DC” pins are active low-level outputs.

Whenever the conditions are met to activate a trigger output, the activation will stay so until the next hardware reset of the device (i.e by a power cycle or by activation of the /RESET input see [figure 3](#)).

Output latching

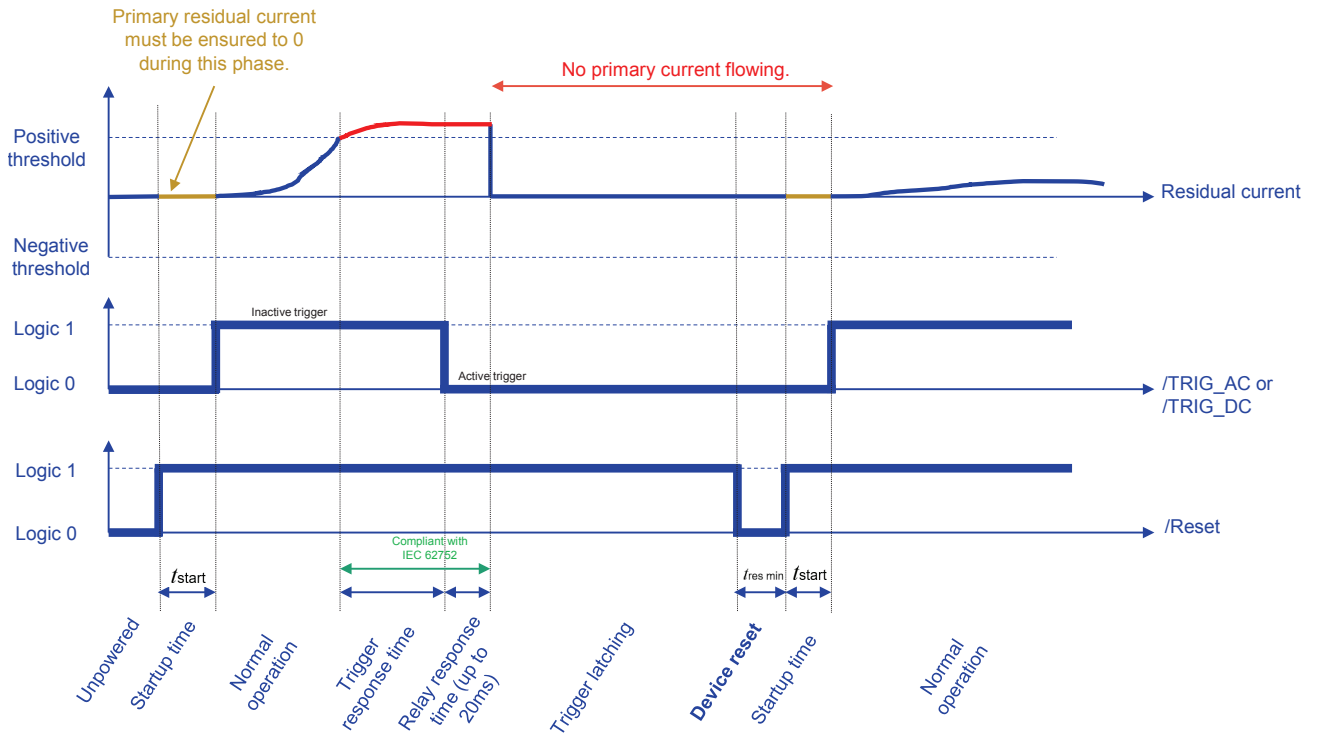
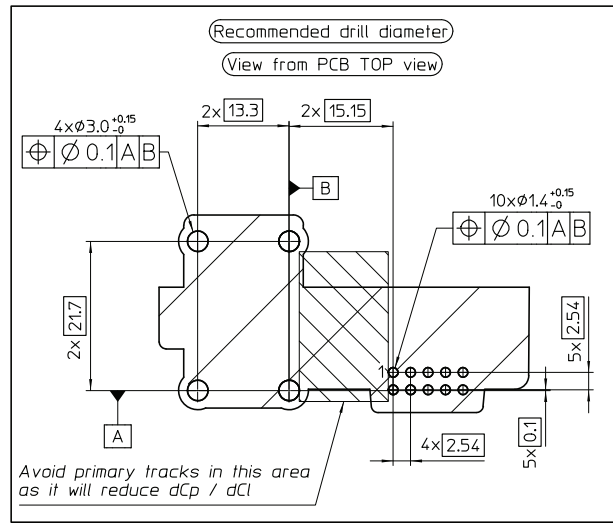

Figure 3: output triggers latching

PCB footprint



Note: The dimension of customer PCB tracks (width & thickness) and the LEM transducer’s primary jumpers are linked and can influence on each other regarding thermal exchanges and self heating.

Assembly on PCB

- Recommended PCB hole diameter Ø 3.0 mm +0.15 mm/-0 mm for primary pin
- Recommended primary via ring diameter: Ø 1.4 mm +0.15 mm/-0 mm for secondary pin
- Recommended primary PCB track cross-section min 3.6 mm
- Recommended primary PCB track cross-section min 2.24 mm²
- Maximum PCB thickness 2.4 mm
- Wave soldering profile maximum 260 °C, 10 s
- No clean process only

Placement:

A clear separation between high voltage components and PCB traces must be respected. The relay must be placed before the output power connector. No tracks downstream the relay shall be routed anywhere near the transducer (“No grid power zone”) but as far as possible from the CDSR.

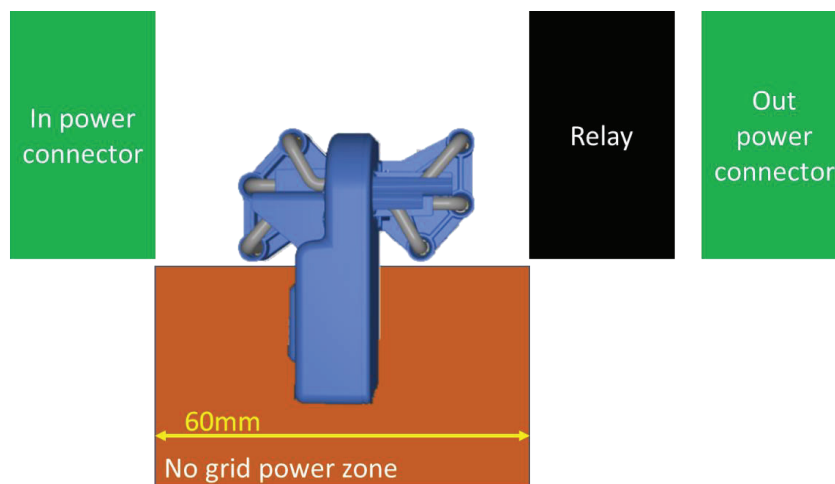

Dimensions (in mm, general tolerance ± 0.6 mm)

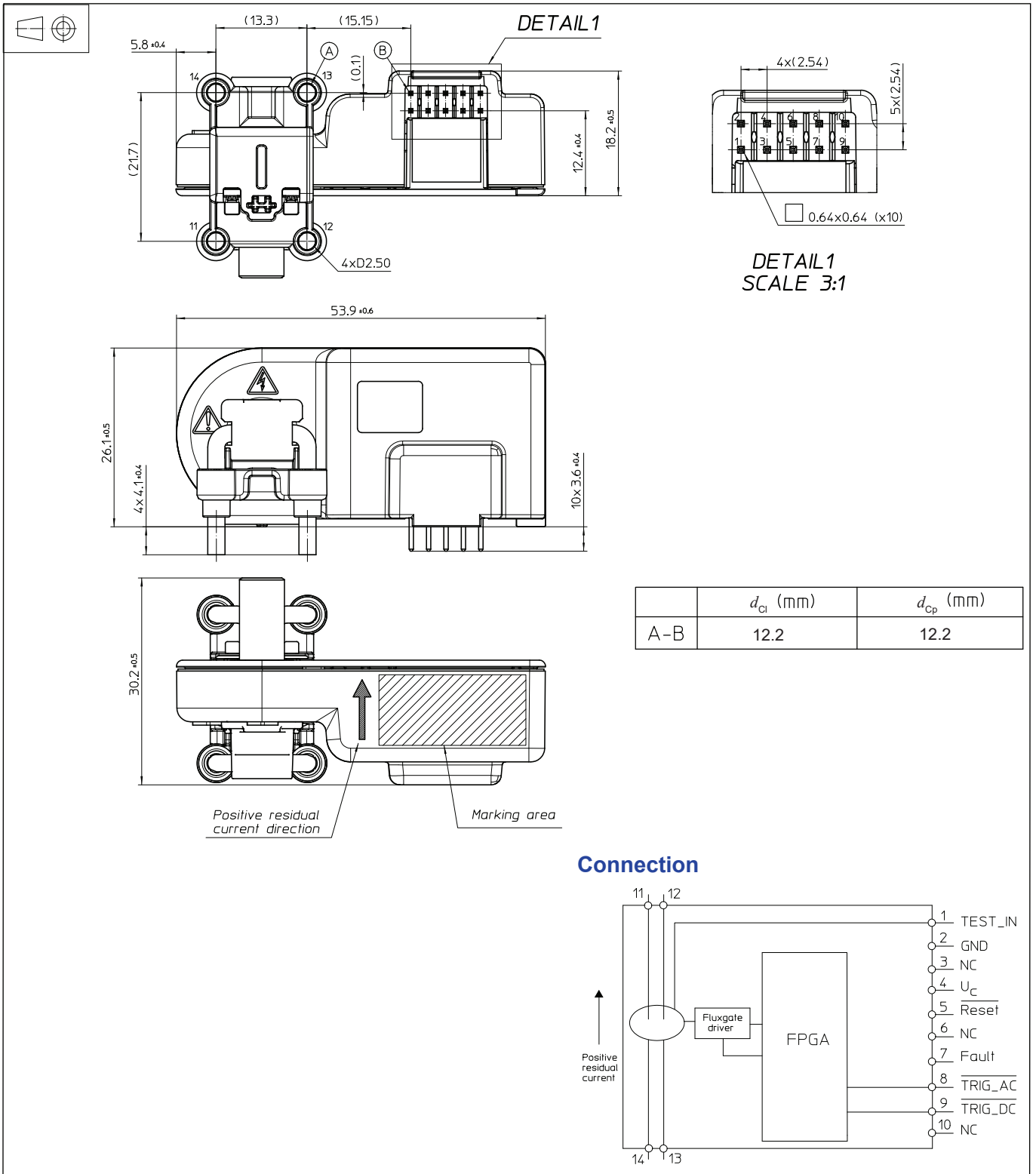

Creepage and Clearance

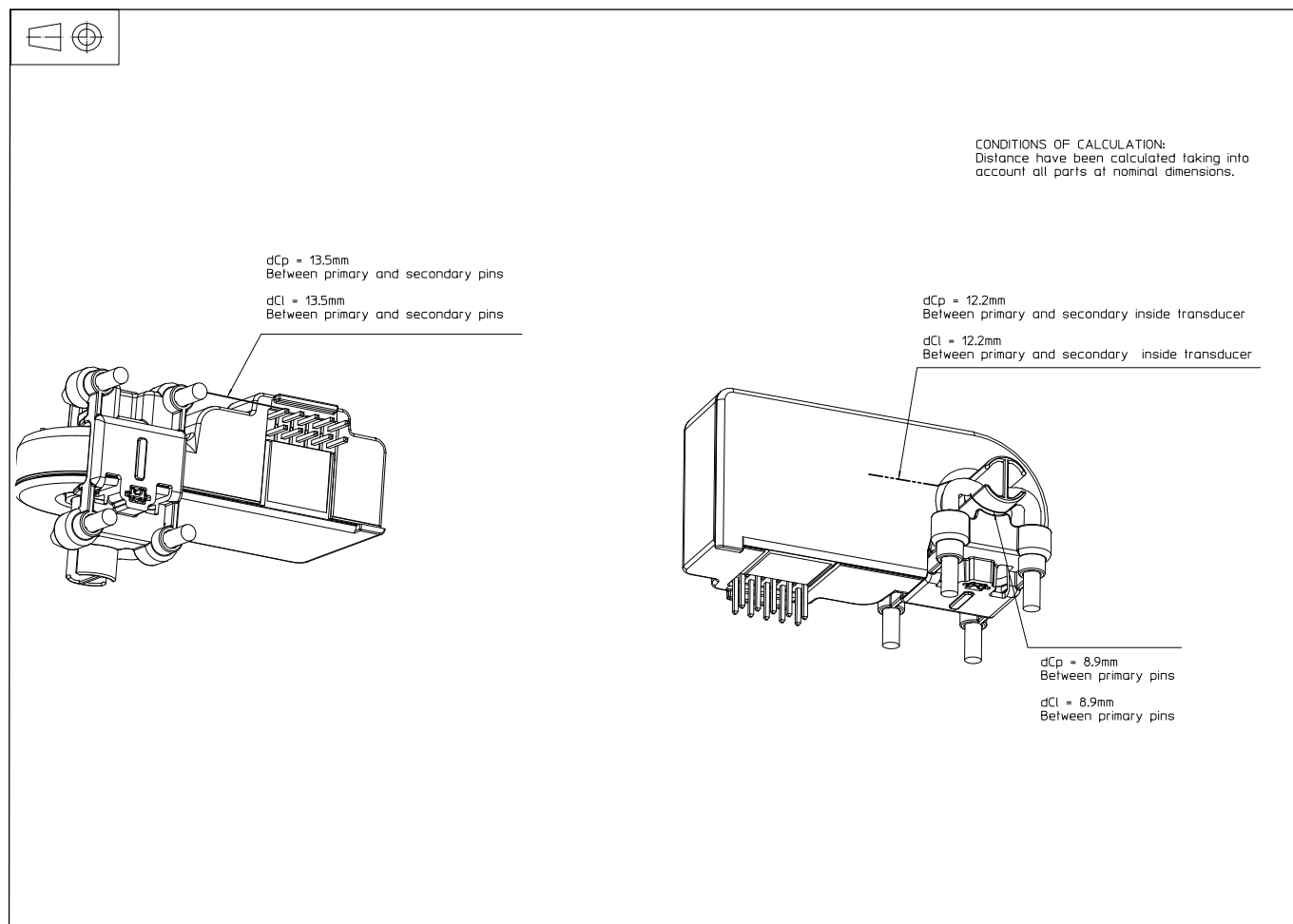

Packaging information

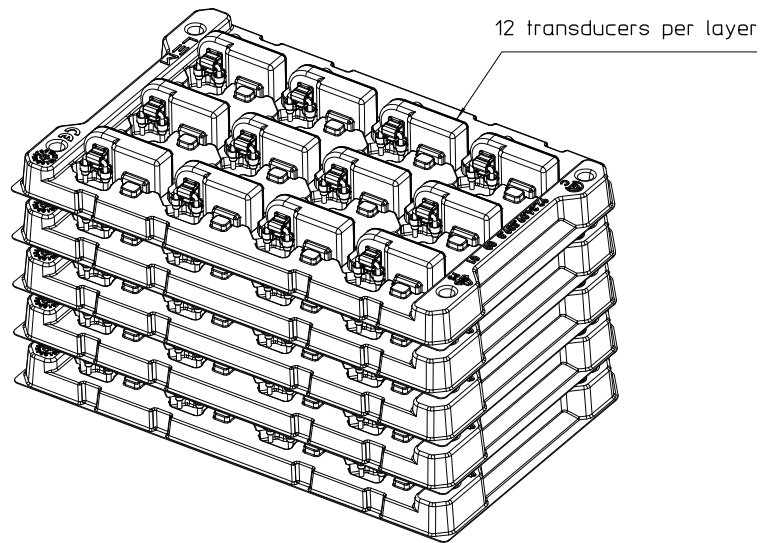

Theoretical stack-up for CDSR 0.07-TPDT

